

Grizzly Industrial, Inc.®

3/4 HP SHAPER **MODEL G0510** **INSTRUCTION MANUAL**



COPYRIGHT © NOVEMBER, 2002 BY GRIZZLY INDUSTRIAL, INC.
**WARNING: NO PORTION OF THIS MANUAL MAY BE REPRODUCED IN ANY SHAPE
OR FORM WITHOUT THE WRITTEN APPROVAL OF GRIZZLY INDUSTRIAL, INC.**

ONLINE MANUAL DISCLAIMER

THE INFORMATION IN THIS MANUAL REPRESENTS THE CONFIGURATION OF THE MACHINE AS IT IS CURRENTLY BEING SHIPPED. THE MACHINE CONFIGURATION CAN CHANGE AS PRODUCT IMPROVEMENTS ARE INCORPORATED. IF YOU OWN AN EARLIER VERSION OF THE MACHINE, THIS MANUAL MAY NOT EXACTLY DEPICT YOUR MACHINE. CONTACT CUSTOMER SERVICE IF YOU HAVE ANY QUESTIONS ABOUT DIFFERENCES. PREVIOUS VERSIONS ARE NOT AVAILABLE ONLINE.

WARNING

Some dust created by power sanding, sawing, grinding, drilling, and other construction activities contains chemicals known to the State of California to cause cancer, birth defects or other reproductive harm. Some examples of these chemicals are:

- Lead from lead-based paints.
- Crystalline silica from bricks, cement, and other masonry products.
- Arsenic and chromium from chemically treated lumber.

Your risk from these exposures varies, depending on how often you do this type of work. To reduce your exposure to these chemicals: work in a well ventilated area, and work with approved safety equipment, such as those dust masks that are specially designed to filter out microscopic particles.

Table Of Contents

		PAGE
1.	SAFETY	2
	SAFETY RULES FOR ALL TOOLS.....	2-3
	ADDITIONAL SAFETY INSTRUCTIONS FOR SHAPERS.....	4
2.	INTRODUCTION	5
3.	CIRCUIT REQUIREMENTS	6
	110V OPERATION	6
	GROUNDING	7
	EXTENSION CORDS	7
4.	IDENTIFICATION	8
	CONTROLS & FEATURES.....	8
5.	SET UP	9
	UNPACKING	9
	PIECE INVENTORY	9
	HARDWARE RECOGNITION CHART	10
	CLEAN UP	11
	SITE CONSIDERATIONS.....	11
	STAND ASSEMBLY	12-13
	FENCE ASSEMBLY	13
	SAFETY GUARD	14
	TEST RUN	14
6.	OPERATIONS	15
	ROTATION	15
	CUTTER INSTALLATION	16
	SPINDLE HEIGHT	16
	FENCE ADJUSTMENT	17
	STRAIGHT SHAPING.....	18
	PARTIAL FACE REMOVAL	19
	PERIMETER CUTTING	19
	RUB COLLARS.....	20
	IRREGULAR SHAPING.....	21-22
	PATTERN WORK	22-23
	SHAPER ACCESSORIES	23
7.	MAINTENANCE	24
	GENERAL	24
	LUBRICATION	24
	TABLE	24
	SCHEDULE.....	25
	V-BELT TENSION.....	25
	MAINTENANCE LOG	26
8.	SERVICE ADJUSTMENTS	27
	PULLEY ALIGNMENT	27
	SPINDLE BEARINGS	27-28
	TRUING THE FENCE.....	28
9.	REFERENCE INFO	29
	MACHINE DATA	30
	WIRING DIAGRAM.....	31
	PARTS BREAKDOWN AND PARTS LISTS	32-33
	WARRANTY AND RETURNS.....	34

SECTION 1: SAFETY

WARNING

For Your Own Safety Read Instruction Manual Before Operating This Equipment

The purpose of safety symbols is to attract your attention to possible hazardous conditions. This manual uses a series of symbols and signal words which are intended to convey the level of importance of the safety messages. The progression of symbols is described below. Remember that safety messages by themselves do not eliminate danger and are not a substitute for proper accident prevention measures.



Indicates an imminently hazardous situation which, if not avoided, WILL result in death or serious injury.



Indicates a potentially hazardous situation which, if not avoided, COULD result in death or serious injury.



Indicates a potentially hazardous situation which, if not avoided, MAY result in minor or moderate injury. It may also be used to alert against unsafe practices.



This symbol is used to alert the user to useful information about proper operation of the equipment.

WARNING

Safety Instructions For Power Tools

1. **KEEP GUARDS IN PLACE** and in working order.
2. **REMOVE ADJUSTING KEYS AND WRENCHES.** Form habit of checking to see that keys and adjusting wrenches are removed from tool before turning on.
3. **KEEP WORK AREA CLEAN.** Cluttered areas and benches invite accidents.
4. **NEVER USE IN DANGEROUS ENVIRONMENT.** Do not use power tools in damp or wet locations, or where any flammable or noxious fumes may exist. Keep work area well lighted.
5. **KEEP CHILDREN AND VISITORS AWAY.** All children and visitors should be kept at a safe distance from work area.
6. **MAKE WORKSHOP CHILD PROOF** with padlocks, master switches, or by removing starter keys.
7. **NEVER FORCE TOOL.** It will do the job better and safer at the rate for which it was designed.
8. **USE RIGHT TOOL.** Do not force tool or attachment to do a job for which it was not designed.

⚠ WARNING

Safety Instructions For Power Tools

9. **USE PROPER EXTENSION CORD.** Make sure your extension cord is in good condition. Conductor size should be in accordance with the chart below. The amperage rating should be listed on the motor or tool nameplate. An undersized cord will cause a drop in line voltage resulting in loss of power and overheating. Your extension cord must also contain a ground wire and plug pin. Always repair or replace extension cords if they become damaged.

Minimum Gauge for Extension Cords

AMP RATING	LENGTH		
	25ft	50ft	100ft
0-6	18		
16	16		
7-10	18		
16	14		
11-12	16		
16	14		

10. **WEAR PROPER APPAREL.** Do not wear loose clothing, gloves, neckties, rings, bracelets, or other jewelry which may get caught in moving parts. Non-slip footwear is recommended. Wear protective hair covering to contain long hair.
11. **ALWAYS USE SAFETY GLASSES.** Also use face or dust mask if cutting operation is dusty. Everyday eyeglasses only have impact resistant lenses, they are NOT safety glasses.
12. **SECURE WORK.** Use clamps or a vise to hold work when practical. It's safer than using your hand and frees both hands to operate tool.
13. **NEVER OVERREACH.** Keep proper footing and balance at all times.

14. **MAINTAIN TOOLS WITH CARE.** Keep tools sharp and clean for best and safest performance. Follow instructions for lubricating and changing accessories.

15. **DISCONNECT TOOLS** before servicing and changing accessories, such as blades, bits, cutters, and the like.

16. **REDUCE THE RISK OF UNINTENTIONAL STARTING.** Make sure switch is in off position before plugging in. Also, the magnetic switch on this machine may start if the switch gets bumped hard enough.

17. **USE RECOMMENDED ACCESSORIES.** Consult the owner's manual for recommended accessories. The use of improper accessories may cause risk of injury.

18. **CHECK DAMAGED PARTS.** Before further use of the tool, a guard or other part that is damaged should be carefully checked to determine that it will operate properly and perform its intended function. Check for alignment of moving parts, binding of moving parts, breakage of parts, mounting, and any other conditions that may affect its operation. A guard or other part that is damaged should be properly repaired or replaced.

19. **NEVER LEAVE TOOL RUNNING UNATTENDED. TURN POWER OFF.** Do not leave tool until it comes to a complete stop.

20. **NEVER USE UNDER THE INFLUENCE** of alcohol or drugs, or when tired.

21. **NEVER ALLOW UNSUPERVISED OR UNTRAINED PERSONNEL TO OPERATE THE MACHINE.** Make sure any instructions you give in regards to the operation of the machine are approved, correct, safe, and clearly understood.

WARNING

Additional Safety Instructions For The Shaper

- 1. DO NOT PLACE YOUR HANDS WITHIN 6 INCHES** of the cutters. Never pass your hands directly over or in front of the cutter. As one hand approaches the 6-inch radius point, move it in an arc motion away from the cutter to the outfeed side and reposition that hand more than 6 inches beyond the cutter.
- 2. DO NOT SHAPE STOCK SHORTER THAN 6 INCHES** without special fixtures or jigs. Where practical, shape longer stock and cut to size.
- 3. BLIND CUT WHENEVER POSSIBLE.** This keeps the cutter on the underside of the workpiece and provides a distance guard for the operator.
- 4. ALWAYS ROTATE THE SPINDLE BY HAND,** with the machine unplugged, to test any new setup to ensure proper cutter clearance before starting the machine.
- 5. WHEN SHAPING CONTOURED WORK** and using a rub collar, **DO NOT** start out at a corner. See the rub collar section further on in the manual. The danger of kick-back is increased when the stock has knots, holes, or foreign objects in it. Warped stock should be run through a jointer before you run it through a shaper.
- 6. KEEP ANY UNUSED PORTION OF THE CUTTER BELOW THE TABLE SURFACE.**
- 7. NEVER ATTEMPT TO REMOVE TOO MUCH MATERIAL IN ONE PASS.** Several light passes are safer and give a cleaner finish.
- 8. THE USE OF PUSH STICKS AS SAFETY DEVICES** in some applications is smart; in others it can be quite dangerous. If the push stick comes in contact with the cutter on the end grain, it can fly out of your hand like a bullet—potentially causing serious injury. We recommend using some type of fixture, jig, or hold-down device as a safer alternative. Use a guard, or other type of protective device at all times.
- 9. ALWAYS FEED AGAINST THE ROTATION OF THE CUTTER.**
- 10. USE OVERHEAD GUARD WHEN FENCE IS NOT IN PLACE.**
- 11. NEVER OPERATE THE SHAPER WITHOUT THE SECOND LOCKING NUT IN PLACE** over the spindle nut.

WARNING

Like all power tools, there is danger associated with the Model G0510 Shaper. Accidents are frequently caused by lack of familiarity or failure to pay attention. Use this tool with respect and caution to lessen the possibility of operator injury. If normal safety precautions are overlooked or ignored, serious personal injury may occur.

CAUTION

No list of safety guidelines can be complete. Every shop environment is different. Always consider safety first, as it applies to your individual working conditions. Use this and other machinery with caution and respect. Failure to do so could result in serious personal injury, damage to equipment or poor work results.

SECTION 2: INTRODUCTION

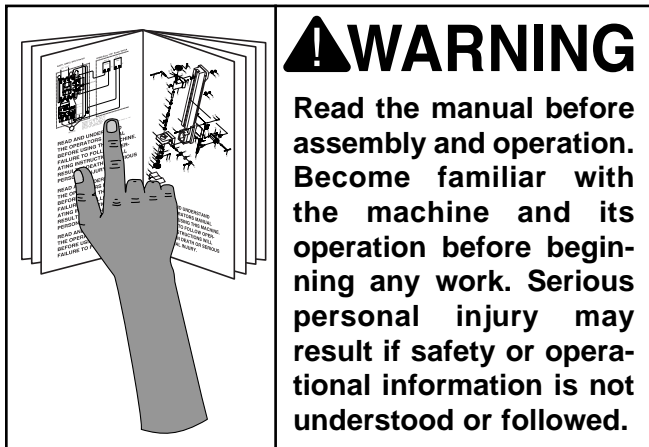

We are proud to offer the Grizzly Model G0510 Shaper. The Model G0510 is part of a growing Grizzly family of fine woodworking machinery. When used according to the guidelines set forth in this manual, you can expect years of trouble-free, enjoyable operation and proof of Grizzly's commitment to customer satisfaction.

The Model G0510 is intended for home use. This shaper incorporates a $\frac{3}{4}$ HP, 110V, single-phase motor with full forward/reverse capabilities. It also operates at either 8900 RPM for maximum versatility.

A number of shaper cutters for the Model G0510 are available through Grizzly. Please refer to the Grizzly catalog or our website at www.grizzly.com for more details.

We are also pleased to provide this manual with the Model G0510. It was written to guide you through assembly, review safety considerations, and cover general operating procedures. It represents our effort to produce the best documentation possible. If you have any comments regarding this manual, please write to us at the address below:

Grizzly Industrial, Inc.
c/o Technical Documentation
P.O. Box 2069
Bellingham, WA 98227-2069

Most important, we stand behind our machines. If you have any service questions or parts requests, please call or write us at the location listed below.

Grizzly Industrial, Inc.
1203 Lycoming Mall Circle
Muncy, PA 17756
Phone: (570) 546-9663
Fax: (800) 438-5901
E-Mail: techsupport@grizzly.com
Web Site: <http://www.grizzly.com>

The specifications, drawings, and photographs illustrated in this manual represent the Model G0510 as supplied when the manual was prepared. However, owing to Grizzly's policy of continuous improvement, changes may be made at any time with no obligation on the part of Grizzly. For your convenience, we always keep current Grizzly manuals available on our website at www.grizzly.com. Any updates to your machine will be reflected in these manuals as soon as they are complete. Visit our site often to check for the latest updates to this manual!



SECTION 3: CIRCUIT REQUIREMENTS

110V Operation

The Model G0510 Shaper motor is prewired to operate at 110V and includes a 110V plug similar to the illustration in **Figure 1**.

Under normal 110V use, the motor draws approximately 10 amps. We recommend a 15 amp circuit breaker or a 15 amp slow-blow fuse.

We recommend using a dedicated circuit, (i.e., the Model G0510 should provide the only draw from that circuit). If frequent circuit failures occur when using the shaper, contact our Service Department or your local electrical contractor.

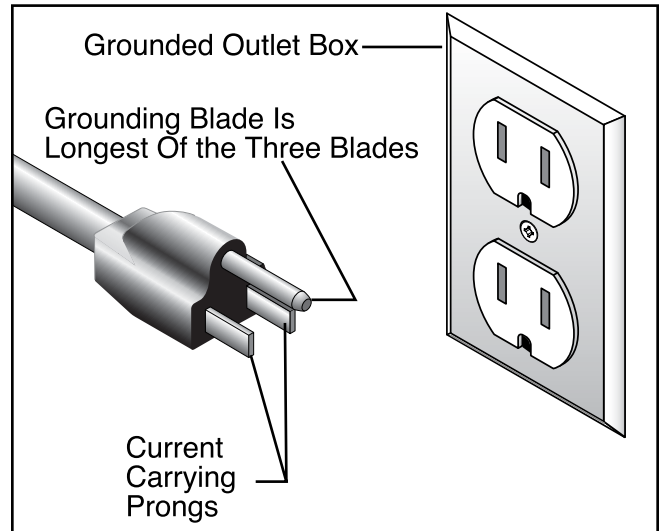

Figure 1. Typical 110V 3-prong plug and outlet.

NOTICE

The Model G0510 cannot be rewired for 220V operation! Attempting to do this will void the warranty and will ruin the machine.



Grounding

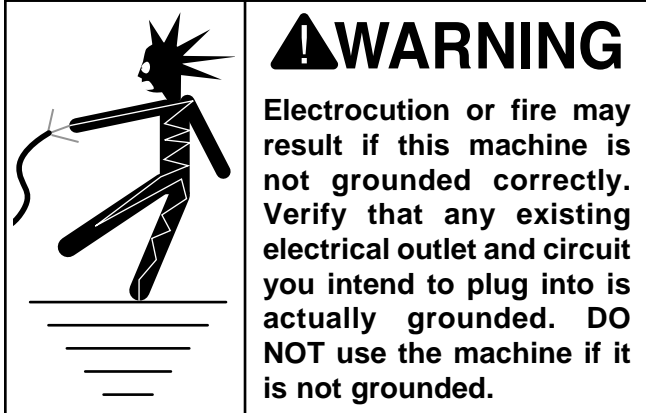

In the event of a malfunction or breakdown, grounding provides electric current a path of least resistance to reduce the risk of electric shock.

This tool is equipped with an electric cord having an equipment grounding conductor. Improper connections of the electrical-grounding conductor can result in the risk of electric shock. The conductor with green or green and yellow striped insulation is the electrical grounding conductor. If repair or replacement of the electric cord or plug is necessary, do not connect the equipment grounding conductor to a live terminal.

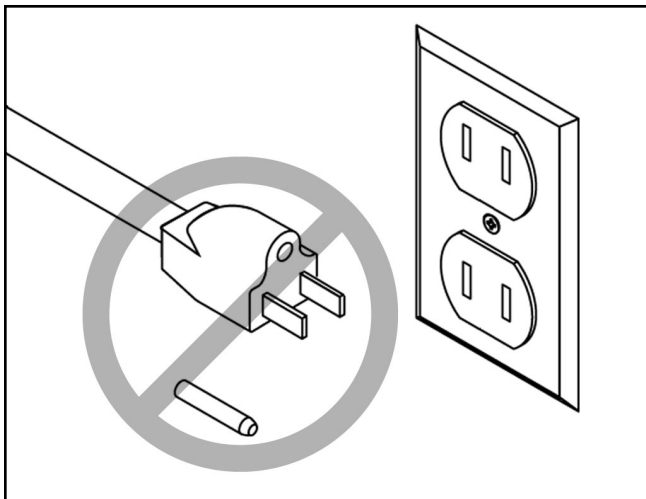

⚠️ CAUTION

This machine must have a ground prong in the plug to help ensure that it is grounded. **DO NOT** remove the ground prong from plug to fit into a two-pronged outlet! If the plug will not fit the outlet, have the proper outlet installed by a qualified electrician.

Check with a qualified electrician or one of our service personnel if the grounding instructions are not completely understood, or if you are in doubt as to whether the tool is properly grounded.



Extension Cords

If you find it necessary to use an extension cord with this machine:

- Only use a cord that is rated for hard service (Grade S).
- Only use a cord that contains a grounding prong.
- Use at least a 18 gauge cord if the cord is 25 feet long or less.
- Use at least a 16 gauge cord if the cord is between 26-50 feet.
- Use at least a 14 gauge cord if the cord is between 51-100 feet.



⚠️ CAUTION

We have covered some basic electrical requirements for the safe operation of your machine. These requirements are not necessarily comprehensive. You must be sure that your particular electrical configuration complies with local and state codes. Ensure compliance by checking with your local municipality or a licensed electrician.

SECTION 4: IDENTIFICATION

Controls & Features

To help you understand the set up and operation instructions, we recommend that you become familiar with the basic features of your new shaper.

Please match up the list below with the letters in **Figures 2 and 3** to identify the shaper controls and features.

- A. Cutterhead Guard
- B. Fence
- C. Starting Pin
- D. Spindle
- E. Spindle Elevation Handle
- F. ON/OFF Switch
- G. Spindle Elevation Lock
- H. Miter Gauge
- I. Fence Lock
- J. Fence Adjustment Knob
- K. Forward/Reverse Switch

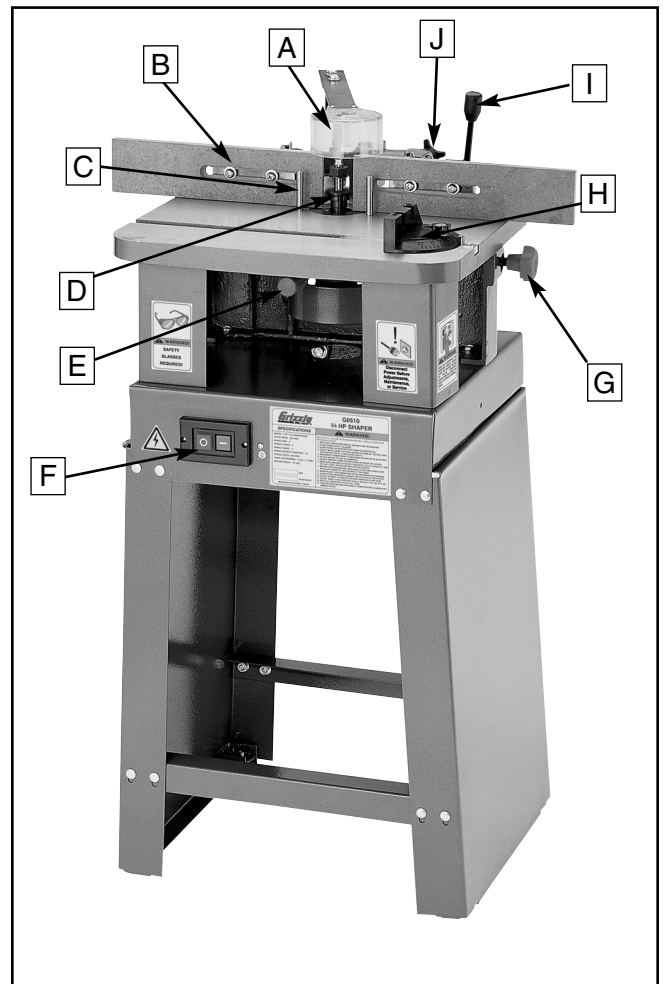

Figure 2. Model G0510 front view controls and features.

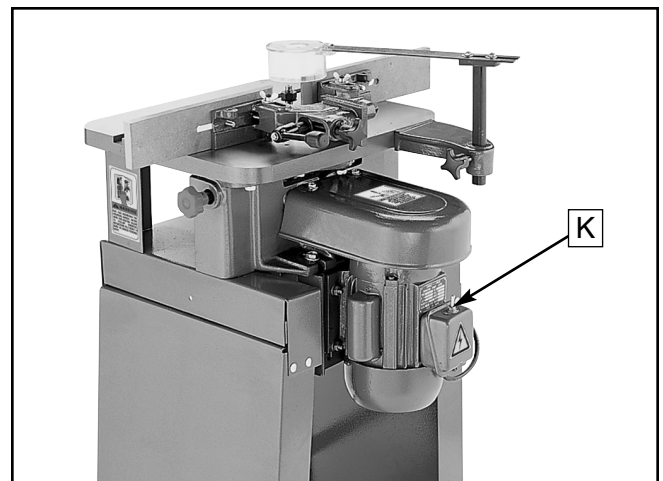



Figure 3. Model G0510 rear view controls and features.

SECTION 5: SET-UP

Unpacking

The Model G0510 $\frac{3}{4}$ HP Shaper is shipped from the manufacturer in a carefully packed carton. If you discover the machine is damaged after you have signed for delivery, and the truck and driver are gone, you will need to file a freight claim with the carrier. Save the container and all packing materials for possible inspection by the carrier or its agent. Without the packing materials, filing a freight claim can be difficult. *If you need assistance determining whether you need to file a freight claim, or with the procedure to file one, please contact our Customer Service.*

	<p>⚠ CAUTION The Model G0510 weighs approximately 155 lbs. DO NOT over-exert yourself while unpacking or moving your machine—get assistance or use a fork lift.</p>
--	---

When you are completely satisfied with the condition of your shipment, you should inventory its parts.

NOTICE

A full parts list and breakdown can be found towards the end of this manual. For easier assembly, or to identify missing parts, please refer to the detailed illustrations at the end of the manual.



Piece Inventory

After all the parts have been removed from the carton, you should have:

- Shaper Unit
- Miter Gauge
- Fence Boards
- Safety Guard
- Stand (4pcs)
- Adjustable Fence (3pcs)
- Hardware
 - Rubber Feet4
 - Hex Bolt M6-1.0 x 124
 - Hex Nut M6-1.0.....4
 - Flat Washer $\frac{3}{8}$ "20
 - Carriage Bolt M8-1.25 x 20.....16
 - Hex Nut M8-1.25.....20
 - Slot Head Screws4
 - Flat Washer $\frac{5}{16}$ "4







In the event that any non-proprietary parts are missing (e.g. a nut or a washer), we would be glad to replace them, or for the sake of expediency, replacements can be obtained at your local hardware store.



Hardware Recognition Chart

Use this chart to match up hardware pieces during the assembly process!

MEASURE BOLT DIAMETER BY PLACING INSIDE CIRCLE

-  #10
-  1/4"
-  5/16"
-  3/8"
-  7/16"
-  1/2"
-  5/8"

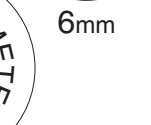
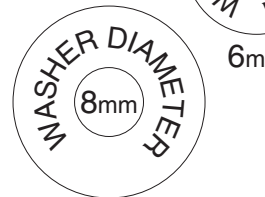
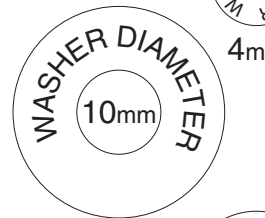
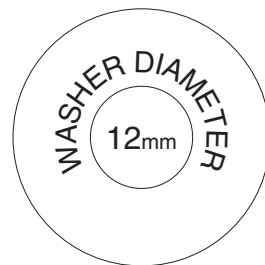
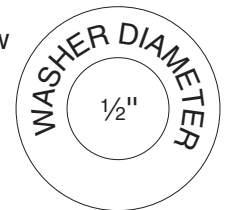
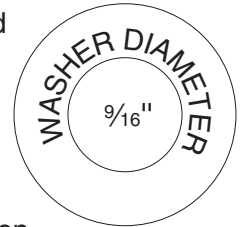
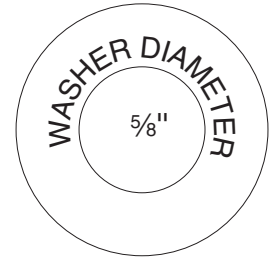
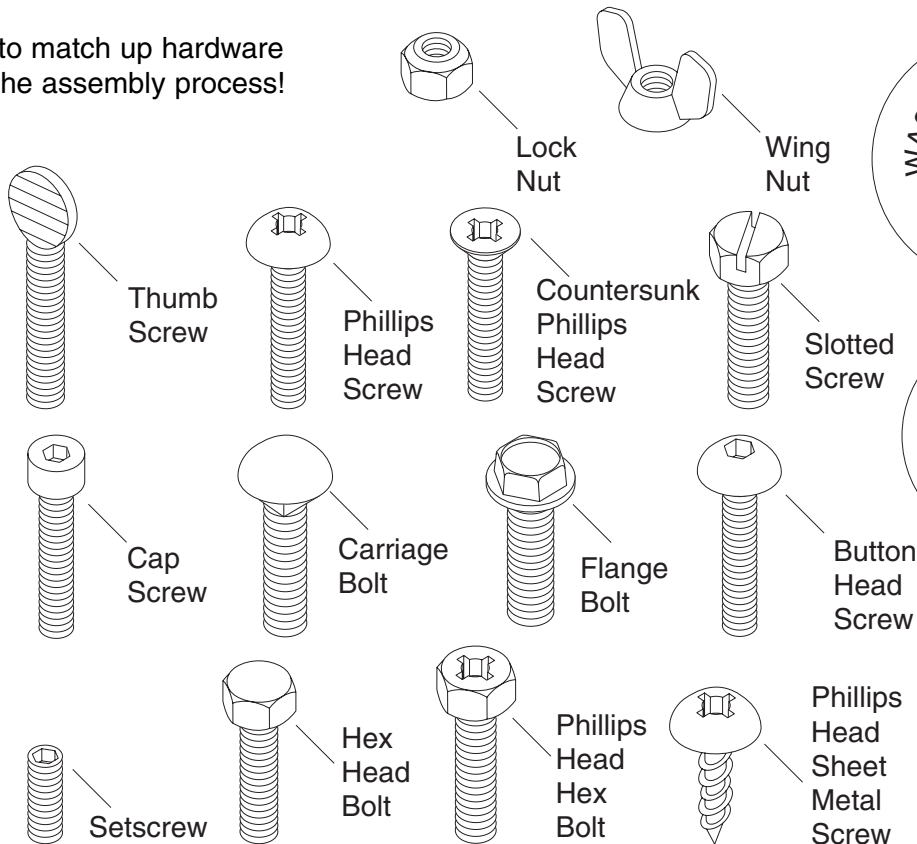

WASHERS ARE MEASURED BY THE INSIDE DIAMETER

LINES ARE 1MM APART

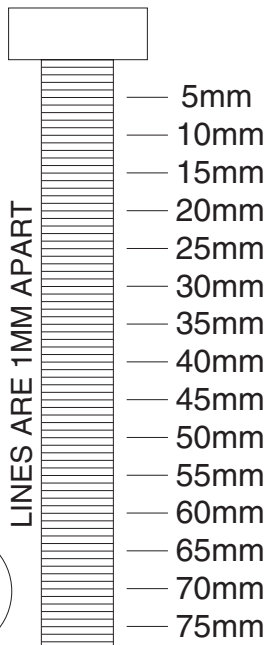

LINES ARE 1/16" APART

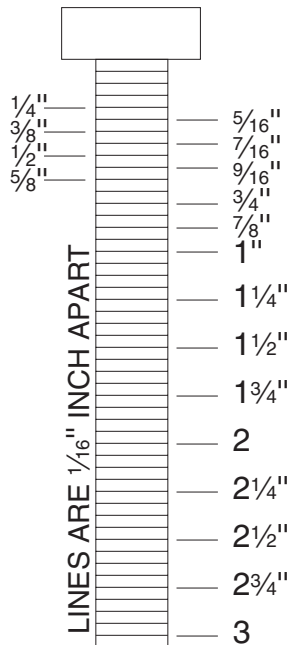

Clean Up

The unpainted surfaces are coated with a waxy oil to protect them from corrosion during shipment. Remove this protective coating with a solvent cleaner or citrus-based degreaser such as Grizzly's G7895 Degreaser. To clean thoroughly, some parts may need to be removed. **For optimum performance from your machine, make sure you clean all moving parts or sliding contact surfaces that are coated.** Avoid chlorine-based solvents as they may damage painted surfaces should they come in contact. Always follow the manufacturer's instructions when using any type of cleaning product.

	<p>! WARNING Do not use gasoline or other petroleum-based solvents to clean with. They have low flash points which make them extremely flammable. A risk of explosion and burning exists if these products are used.</p>
--	---

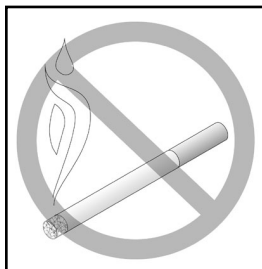
	<p>! WARNING Do not smoke while using solvents. A risk of explosion or fire exists and may result in serious personal injury.</p>
---	--

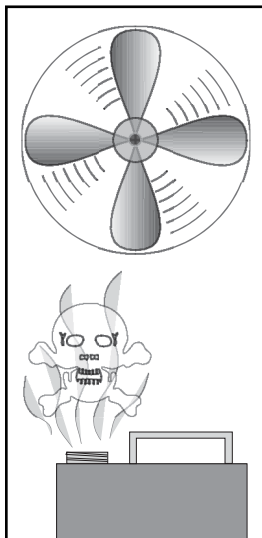
	<p>! CAUTION Many of the solvents commonly used to clean machinery can be toxic when inhaled or ingested. Always work in well-ventilated areas far from potential ignition sources when dealing with solvents. Use care when disposing of waste rags and towels to be sure they do not create fire or environmental hazards.</p>
---	---

Site Considerations

FLOOR LOAD

Your new shaper represents a moderate weight load in a small sized footprint. Most shop floors will be adequate for the weight of this machine; however, some floors may require additional support. Contact an architect or structural engineer if you have any question about the ability of your floor to handle the weight.

WORKING CLEARANCES

Working clearances can be thought of as the distances between machines and obstacles that allow safe operation of every machine without limitation. Consider existing and anticipated machine needs, size of material to be processed through each machine, and space for auxiliary stands or work tables. Also consider the relative position of each machine for efficient material handling. Be sure to allow yourself sufficient room to safely run your machines in any foreseeable operation.

LIGHTING AND OUTLETS

Lighting should be bright enough to eliminate shadow and prevent eye strain. Electrical circuits should be dedicated or large enough to handle combined motor amp loads. Outlets should be located near each machine so power or extension cords are not obstructing high-traffic areas. Be sure to observe local electrical codes for proper installation of new lighting, outlets or circuits.

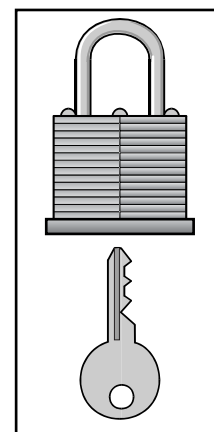
	<p>! CAUTION Make your shop "child safe." Ensure that your workplace is inaccessible to children by closing and locking all entrances when you are away. DO NOT allow unsupervised children or visitors in the shop at any time.</p>
--	--



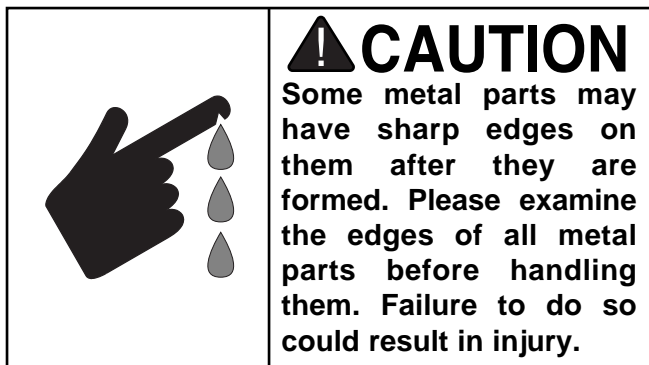
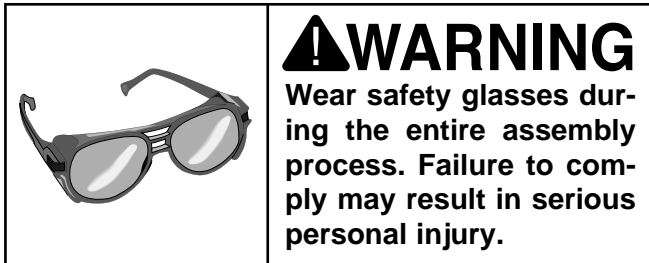
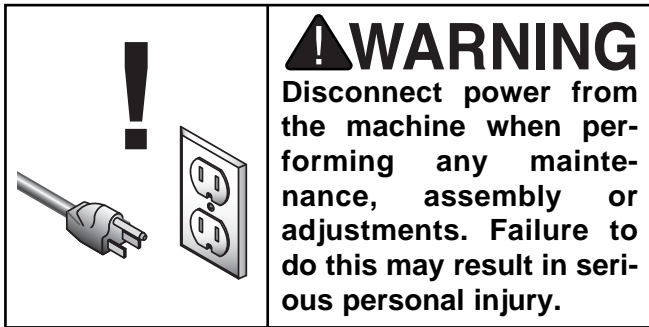

Stand Assembly

The Model G0510 Shaper features an A-frame stand.

To assemble the stand:

1. Lay one stand side on the ground and attach the cross bars with the M8 carriage bolts, $\frac{3}{8}$ " washers, and M8 hex nuts as shown in **Figure 4**. DO NOT fully tighten the nuts and bolts at this time.
2. Attach the second stand side to the assembly. *Note—At this point, the assembly will be somewhat wobbly. Have an assistant hold the assembly in place while you attach the nuts and bolts.*

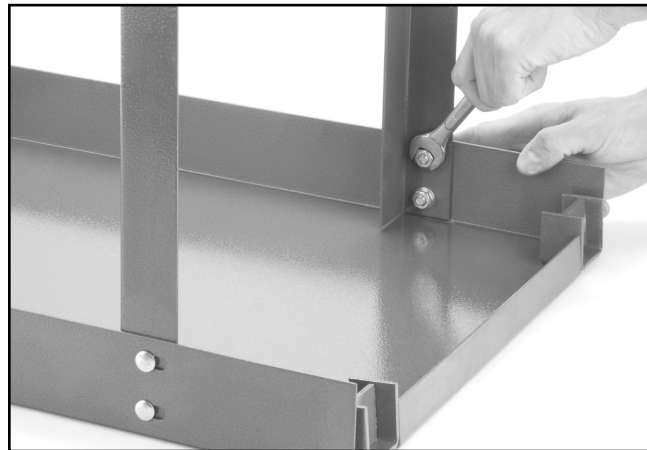

Figure 4. Attaching cross bars to stand side.

3. Attach the 4 rubber feet to the bottom of the side panels with the M6-1.0x12 hex bolts, M6-1.0 hex nuts and $\frac{3}{8}$ " flat washers provided. See **Figures 5 and 6**.

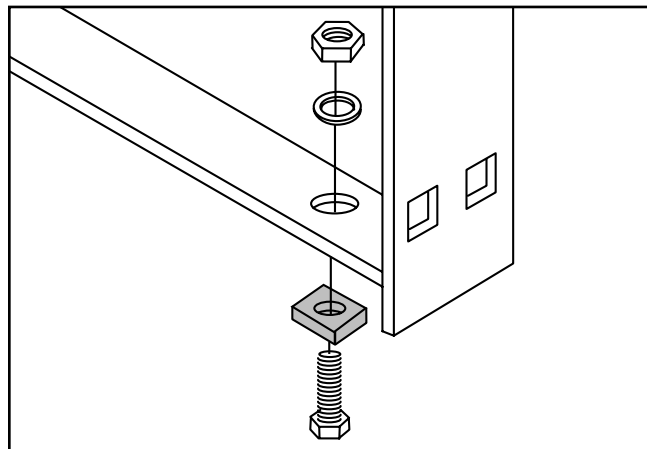

Figure 5. Rubber foot assembly order.



Figure 6. Attaching rubber feet to stand assembly.

4. Place the shaper table upside down on two sturdy blocks that are at least 3½" off the ground as shown in **Figure 7**. Make sure the spindle DOES NOT touch the ground or the weight of the shaper may damage the spindle.
5. Place the stand assembly on the shaper and attach it with the M8 carriage bolts, ⅜" washers, and M8 hex nuts as shown in **Figure 7**.



Figure 7. Attaching stand to shaper unit.

6. Have an assistant help you turn the shaper unit rightside-up.
7. Level the shaper with a carpenter's level, then tighten all of the assembly bolts on the stand.

NOTE: Sheet steel will often “spring” after it has been fabricated at the factory, occasionally making it difficult to line up precisely with other parts without a bit of effort. Do not be surprised if the stand requires a bit of “persuasion” to fit together. On the other hand, if the parts just do not seem to work together, try switching parts around (such as crossbars). If that does not work, call our service department and we will help you remedy the situation.



Fence Assembly

The Model G0510 Shaper comes with a two-piece adjustable fence. The wood fence pieces included with the Model G0510 are pre-drilled and countersunk to allow the slotted mounting screws to rest below the wood surface once they are tightened. *Note—Most woodworkers like to replace the wood pieces on the fence with wider and thicker boards. This gives the user greater stability and a larger bearing surface.*

The following procedure will ensure that the fence is parallel with itself and square with the table:

1. Ensure that the bolts on each side are tight and adequately countersunk.
2. To align the wood fences, adjust one or both fence halves so they are in close alignment. Micro-adjust and check the alignment with a good straightedge.
3. If the boards are not coplanar with each other, resurface the wooden fences as one unit. You can perform this operation on a jointer.

NOTICE

If you resurface your fence faces, make sure the fence mounting bolt holes are countersunk deep enough so the jointer knives will not come in contact with the heads of the bolts!

4. Once you are satisfied that the fence is coplanar, mount the fence assembly on the shaper table. The mounting studs are already attached to the table. All you will need to do is remove the nuts, place the fence assembly on the studs and retighten the nuts.



Safety Guard Assembly

The Model G0510 features a clear acrylic safety guard that is designed to deflect wood chips away from the operator.

To attach the guard:

1. Slip the support rod into the hole in the bracket that is bolted to the back of the shaper table. See **Figure 8**.

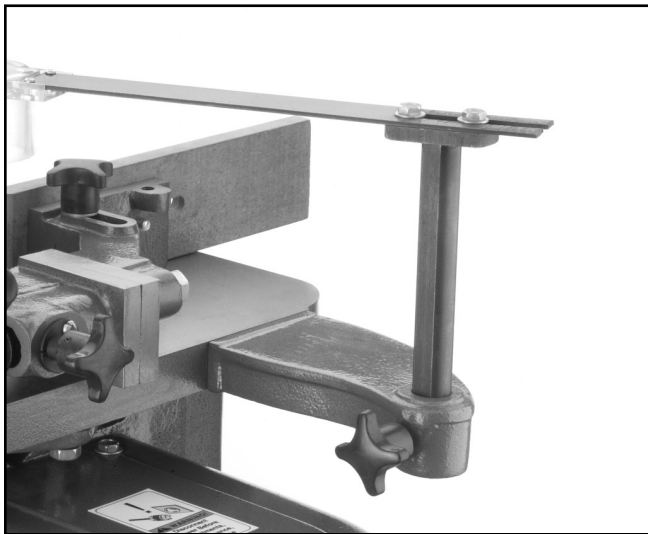

Figure 8. Support rod attached to bracket.

2. Adjust the height of the safety guard.
3. Lock the bracket knob to keep the safety guard in place.

WARNING

The guard protects the operator from inadvertent contact with the cutter which could cause serious personal injury. **DO NOT** operate the shaper with the guard removed. Always replace the guard before operation if it has been removed for machine service or maintenance.



Test Run

Once assembly is complete, you are ready to test run the machine.

WARNING

DO NOT attempt to investigate or adjust the machine while it is running. Wait until the machine is turned off, unplugged and all working parts have come to a complete stop before you do anything!

Turn on the power supply at the main panel. Press the START button. Make sure that your finger is poised on the STOP button, just in case there is a problem. The shaper should run smoothly, with little or no vibration or rubbing noises. Strange or unnatural noises should be investigated and corrected before operating the machine further.

If the shaper seems to be running correctly, check the directional switch. The spindle should be rotating in a counterclockwise direction when the switch is in the FORWARD position. Run the Model G0510 for a short time to ensure that the moving parts are working properly with no excessive vibration. If any problem develops, correct it before attempting to use the machine.

If you cannot locate the source of unusual noises, feel free to contact our service department for help.



SECTION 6: OPERATIONS



⚠️ WARNING

Wear safety glasses during the entire operation process. Failure to comply may result in serious personal injury.

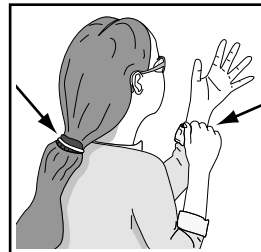

⚠️ WARNING

Keep loose clothing out of the way of machinery and keep hair pulled back during operations.

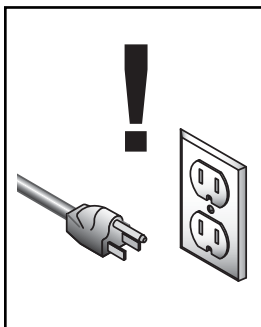

⚠️ WARNING

Disconnect power from the machine when performing any maintenance, assembly or adjustments. Failure to do this may result in serious personal injury.

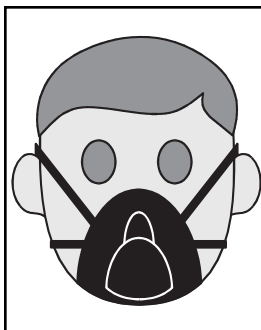

⚠️ CAUTION

Always wear a dust mask when operating this shaper. Using this machine produces sawdust that may cause short and long-term respiratory illness.

NOTICE

The following section was designed to give instructions on the basic operations of this shaper. However, it is in no way comprehensive of every shaper application. **WE STRONGLY RECOMMEND** that you read books, trade magazines, or get formal training to maximize the potential of your shaper.

Rotation

Your shaper is equipped with a FWD/REV (forward and reverse) switch. **See Figure 9.** In many instances, it will be necessary to flip the cutter over and reverse the cutter rotation. Whenever possible, mount the cutter so the board is milled on the bottom side (the side away from the operator). This does a better job and it is safer for the operator.

Always check the direction of the cutter rotation before any shaping operation.



Figure 9. FWD/REV switch.



Cutter Installation

Your shaper operates at 8900 RPM. Always use 1/2" shaper cutters and never attempt to use router bits!

To install a shaper cutter:

1. **Disconnect the shaper from the power source!**
2. Place an appropriate spacer or collar (if needed) at the base of the spindle for support.
3. Place the cutter on the spindle. Make sure the rotation is correct for your application.
4. Use spacers or collars as needed for your particular application.
5. Place the spindle washer on top of the spacers/cutter, and thread on the locknut.
6. Tighten the nuts while holding the spindle stationary. Use a wrench on the notches at the top of the spindle for leverage. **See Figure 10.**



Figure 10. Tightening spindle lock nut.



Spindle Height

To adjust the cutter height:

1. Loosen the spindle lock shown in **Figure 11**.
2. Move the spindle up or down with the elevation adjustment handle, shown in **Figure 12**, until the desired position is obtained.
3. Lock the spindle into position.

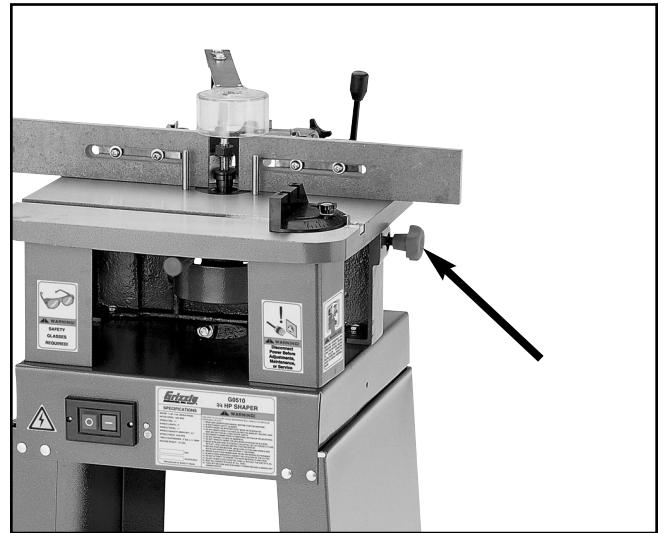

Figure 11. Spindle height lock knob.

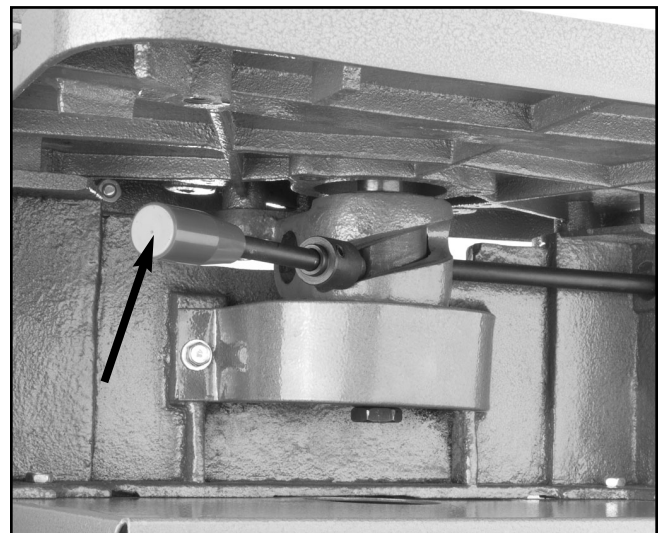

Figure 12. Spindle elevation adjustment handle.



Fence Adjustments

The fence is a two-piece adjusting system. Each fence is independently adjustable to compensate for different cutting thicknesses and special shaping applications. See **Figure 13**. One turn of the knob moves the split fence approximately $\frac{3}{64}$ " (.040"). When removing material from the whole face of your workpiece, the outfeed fence should be adjusted to the proper offset to provide support for the workpiece as it passes over the cutter.

⚠️ WARNING

Read through the entire manual carefully before attempting to make any cuts with your shaper. Otherwise, serious personal injury could occur.

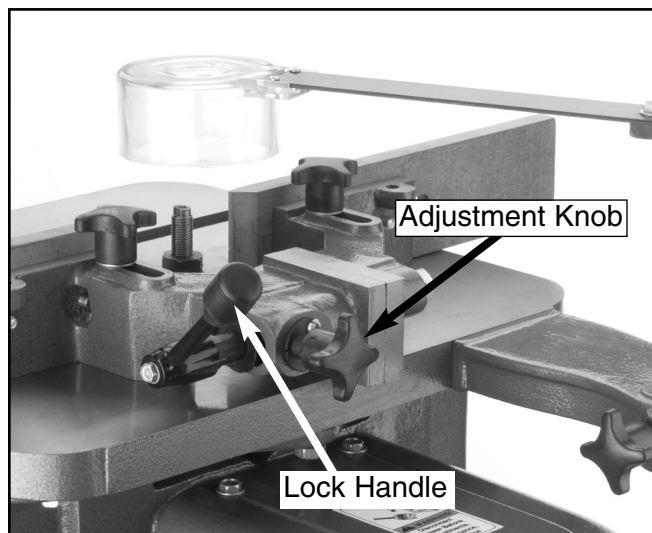

Figure 13. Fence adjustments.

To adjust the fence for straight shaping:

1. Loosen the lock handle.
2. Adjust the infeed fence by turning the knurled adjustment knobs, so the cutter will remove the desired amount of stock.
3. A test piece can help determine the best setting. Select the wood for the test piece that most closely resembles the actual workpiece.
4. Lock the infeed fence in position with the locking handle to prepare to make a test cut.

⚠️ WARNING

The miter gauge should not be used to feed material along the fence face when straight shaping. Use a push stick and hold-downs to keep the workpiece in position. The fence may not always be perfectly parallel to the miter slot; therefore, using the miter gauge can cause binding and possible kickback of the workpiece towards the operator. Serious personal injury could occur if this happens.

5. Turn the shaper *ON* and advance a 36" or longer test sample of the desired cut about 8", then stop. Swing the test piece away from the cutter and turn the machine *OFF*.
6. When the cutter comes to a complete stop, adjust the outfeed fence to support the new profiled edge. Lock the outfeed fence into position and retest. See **Figure 14** and **Figure 15** for improper and proper outfeed fence positioning.

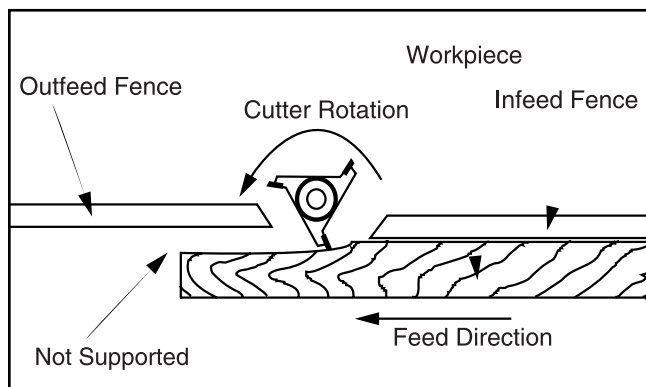

Figure 14. Improper fence adjustment.

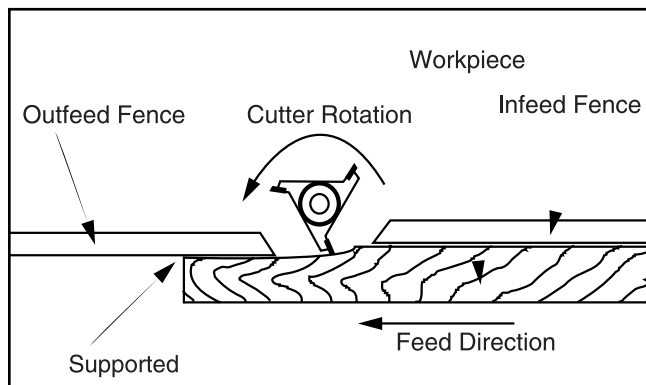

Figure 15. Proper fence adjustment.



Straight Shaping

When shaping straight stock, use the fence assembly. See the *fence adjustment* section for information on aligning fences.

To shape a piece of straight stock:

1. Select the appropriate cutter and lock it onto the spindle.
2. Check cutter rotation.
3. Adjust the spindle height to align the workpiece to the cutter. See the spindle height section for details.
4. Lock the spindle height into position.
5. Position the fences for your desired depth of cut. See the fence adjustment section for details.
6. Use a hold-down, or other safety device (see **Figures 16 and 17**), and put on your safety glasses and dust mask.



Figure 16. Safety boards and push stick in use.



Figure 17. Anti-kickback board buddies in use. (Guard removed for clarity—ALWAYS use the guard!)

7. Make a sample cut on a scrap piece of wood to check your adjustments.
8. If everything is correct, run your stock through the shaper using your left hand to support the workpiece against the fence and your right hand to feed (if the rotation is counterclockwise) as shown in **Figure 18**. Switch hands for clockwise rotation. Note—*Only use the miter gauge to shape the ends of your workpiece.*



Figure 18. Feeding workpiece into shaper, wearing safety glasses and dust mask.



Partial Face Removal

If the face of the workpiece will only be partially removed, observe the following steps:

1. Adjust the infeed fence to approximately the desired depth of cut, and lock the infeed fence in place.
2. Use a straightedge to adjust the outfeed fence to the same plane as the infeed fence, and lock the outfeed fence in place.
3. Set the right and left wood faces to barely clear the cutter. This allows the maximum support possible for the workpiece while passing the cutter. Remember to tighten down the wood facing before starting the shaper.
4. Run a test piece through the shaper. See **Figure 19**.

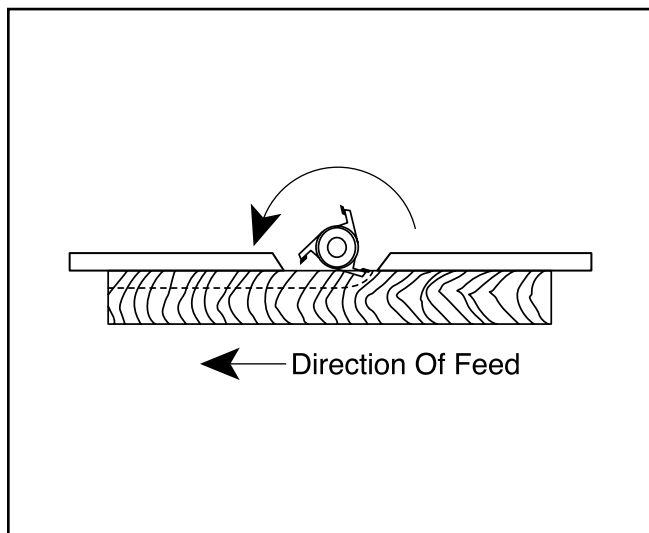

Figure 19. Partial feed fence adjustment.



Perimeter Cutting

If an edge around the perimeter of a workpiece is to be cut, observe these steps:

1. Cut the sides with end grain first.
2. Cut the sides with the grain last, or in the sequence shown in **Figure 20**.

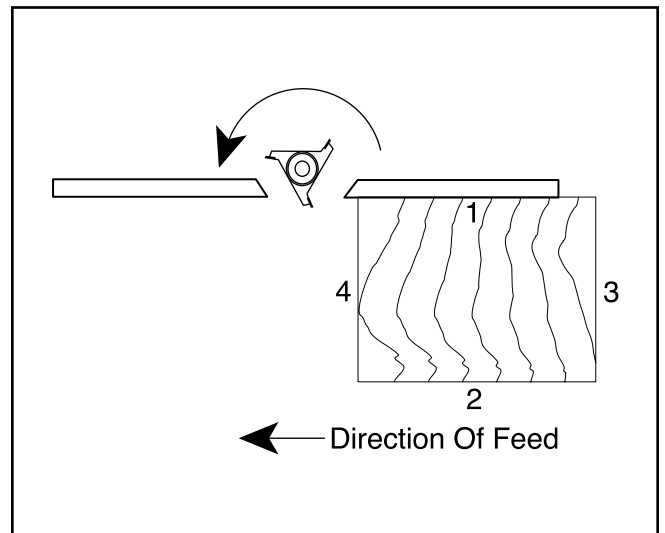

Figure 20. Cut sides with end grain first.



Rub Collars

Rub collars are used when shaping curved or irregular workpieces, such as arched doors or round table tops, and to limit the depth of your cut.

There are two types of rub collars—solid and ball-bearing. While the Model G0510 comes with solid rub collars, we carry an extensive line of ball bearing rub collars as upgrades. See the current Grizzly catalog or www.grizzly.com for listings.

Rub collars may be used in any of the following positions:

1. **Rub collar below the cutter:** When the rub collar is placed below the cutter, **See Figure 21**, the progress of the cut can be observed. However, any unintentional movement may lift the workpiece into the cutter, damaging your work and creating a dangerous situation. *We DO NOT recommend using the rub collar in this position.*

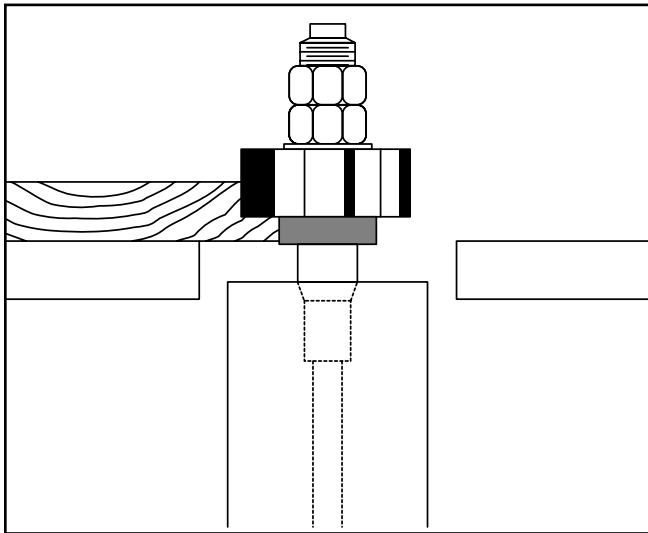

Figure 21. Cutting with rub collar below cutter.

2. **Above the cutter:** When the rub collar is used above the cutter, the cut cannot be seen. See **Figure 22**. This offers some advantage—the stock is not affected by slight variations in thickness and accidental lifting will not damage the workpiece. Simply correct any change in height by repeating the operation.

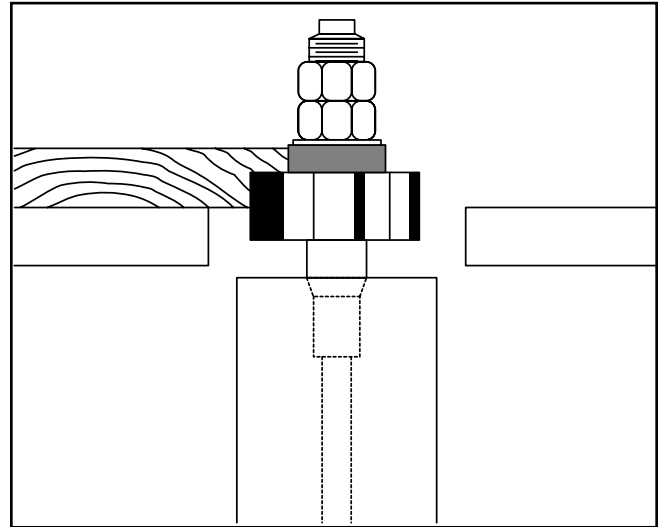

Figure 22. Cutting with rub collar above cutter.

3. **Between two cutters:** Using a rub collar between two cutters has the distinct advantage of performing two cuts at once or eliminating the need to change cutters for two different operations. **Figure 23**. Notice that part of the edge is left uncut. The uncut portion rides on the rub collar.

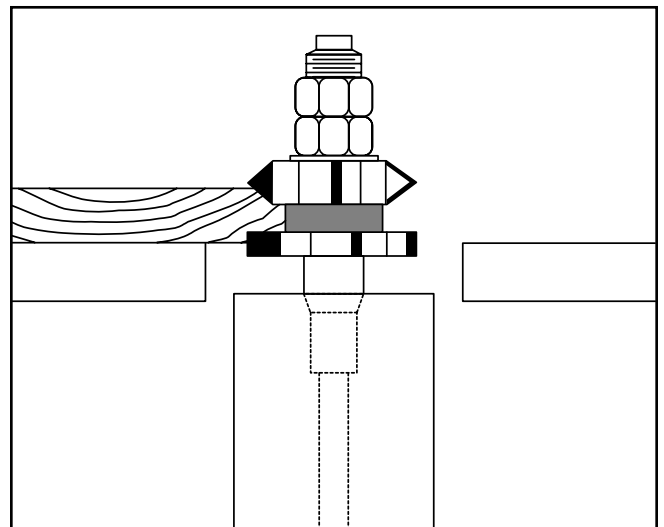

Figure 23. Using rub collar between cutters.



Irregular Shaping

⚠️ WARNING

Freehand shaping greatly increases the chance that the operator may lose control of the workpiece; therefore, use a starting pin to increase control while freehand shaping. Loss of control could result in loss of fingers or other serious personal injury.

Irregular or freehand shaping takes a high degree of skill and dexterity. The fence assembly is not used in irregular shaping, so rub collars must be used. See the rub collar section for details. Also, unless your jig is designed to touch the rub collar before contacting the blade, a starting fixture must be used to begin your cut.

When doing freehand work, a starting pin must be used. The purpose of the starting pin is to support the workpiece during the beginning of the cut. Your shaper is supplied with a starting pin that can be placed in one of the holes located in the shaper table. The work should be placed in the starting position, using the starting pin for support as illustrated in **Figure 24**.

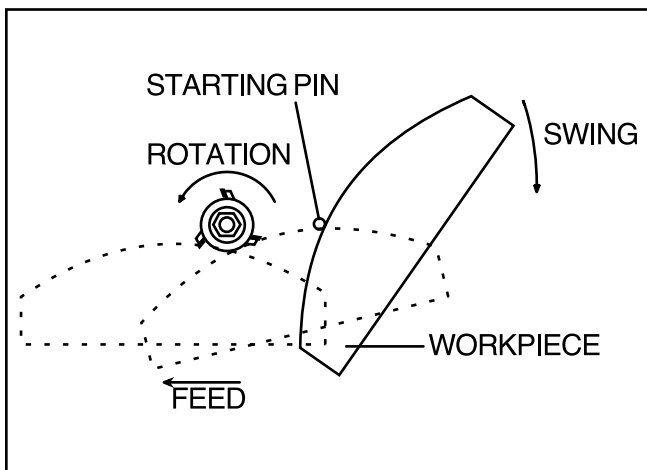

Figure 24. Always feed against cutter rotation.

Next, swing the work into the cutter while holding the workpiece firmly against the starting pin. After the cut has been started, the work should be swung away from the starting pin and is supported just by the rub collar, as shown by the broken line positions in **Figure 24**.

ALWAYS FEED AGAINST THE ROTATION OF THE CUTTER.

For irregular shaping:

1. Remove the fence assembly.
2. Choose the appropriate cutter for your application and lock it in place.
3. Check the rotation of the cutter.
4. Adjust the spindle height to align your workpiece to the cutter.
5. Insert a starting pin into the table surface, using the pin location that best supports your work.
6. Use some type of hold-down fixture and guard when doing freehand work.

⚠️ CAUTION

Incorrectly feeding stock—feeding **WITH** the rotation of the cutter—creates a potentially uncontrollable feed situation that may pull stock from your hands. Follow the above instruction all the time or serious personal injury can occur.

7. Make a sample cut on a piece of scrap wood.
8. If everything is correct, feed your workpiece along the cutter, using firm pressure to keep your work against the rub collar. Feed **AGAINST** the cutter rotation only.

Pattern Work

Sometimes the starting pin will not be in the most advantageous position. To remedy this situation, firmly clamp a board in the desired position to act as a starting fixture. **See Figure 25.** Some type of pivot point **must be** used.

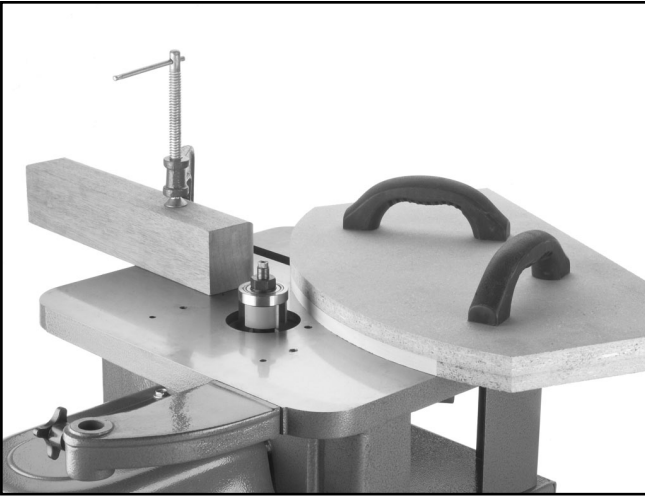

Figure 25. Starting fixture in place for jig.

The purpose of the starting fixture is to support the workpiece during the beginning of the cut. The workpiece is typically placed in the starting position, using the starting fixture for support, then swung into the cutter while holding the workpiece firmly against the starting fixture. After the cut has been started, the work is swung away from the starting fixture and is supported only by the rub collar. **Always feed AGAINST the rotation of the cutter and do not start cuts at corners.**

When using a solid rub collar, do not use excessive pressure when running your workpiece through the shaper. Otherwise, a groove may burn into your pattern and be transferred to your workpiece. Instead, take several passes, using lighter pressure against the rub collar. If you find this to be a consistent problem, you may consider using ball bearing rub collars instead of solid collars.



When using a pattern, the rub collar can be positioned either above, below, or between cutters.

The pattern is usually used when the entire edge is to be shaped or when many duplicate pieces are needed. Pattern work is particularly useful when rough cutting irregular shapes oversize and then shaping the edge in a simple two-step operation. A pattern can be incorporated into a fixture by way of adding toggle clamps, hand holds, or other safety devices.

You have greater flexibility when choosing the correct diameter rub collar for pattern work than for non-pattern work. If you look at **Figure 26**, you will notice that the position of the pattern determines the depth of cut. In other words, your pattern size is dependent upon the inter-relationship of cutting circle, the desired amount of material removed and the rub collar size. The cutting circle is the given in the equation, while the pattern and the rub collar size are the variables. Changing one or both of these will change the amount of material removed. Planning ahead, you can best decide which rub collars are best suited for your application.

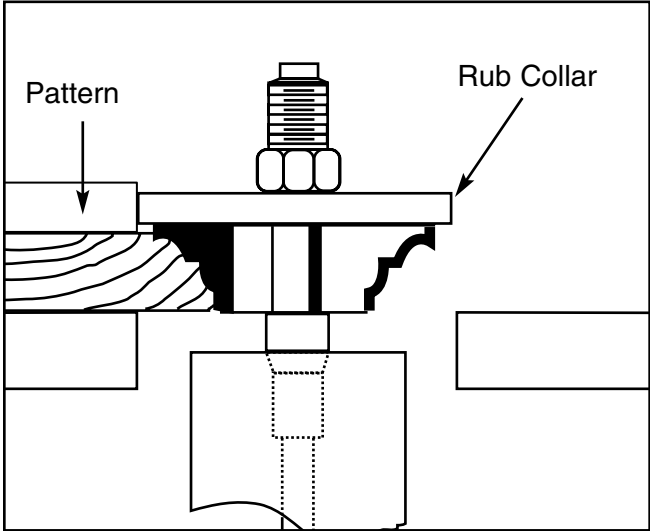

Figure 26. Rub collar determines depth of cut.

When making a pattern, jig, or fixture, here are a few things to consider:

1. Use a material that will smoothly follow the rub collar or fence.
2. Secure your workpiece (on the three sides that will not be cut) with toggle clamps, or fasten the workpiece to the jig with wood screws.
3. Make the jig stable, using proven methods and materials, and fasten the hand holds for operator comfort and safety.
4. Secure your workpiece on three sides with toggle clamps or fasten the workpiece to the fixture with wood screws. Make sure they do not protrude through the workpiece.
5. Ensure that clamps and hidden screws do not come into contact with the cutter.
6. Design your fixture so that all cutting occurs underneath the workpiece.
7. Always consider cutting circle and rub collar diameter for correct depth of cut when designing your pattern.
8. Make sure the workpiece rests flat on the table, not on the fixture.
9. Remember, there is tremendous cutting force on the workpiece. Fixtures must be solid, stable and the workpiece must be firmly secured.

NOTICE

Use care in designing and making fixtures. Clamps and screws cannot touch the cutter, and the fixtures must be stable in use, with the workpiece resting on the shaper table, not on the fixture. The workpiece must be fixed securely to the jig.



Shaper Accessories

Many experienced shaper users regularly use proven shop-made fences and safety guards to augment their shaping operations.

Here are some basic accessories and their uses:

- **Zero Clearance Fence** — A shop-made fence with an opening only as large as the cutter, so that only the part of the cutter being used is exposed.
- **Box Fence** — A shop-made box that completely surrounds the cutter. A one-piece fence is attached that allows only the thickness of the board to pass underneath, thereby completely shielding the operator from exposure to the spinning cutter. A clear plexiglass window on top of the box allows the operator to view the workpiece during cutting.

Because of the wide range of fences and guards that can be built in the shop, explaining their construction is beyond the scope of this manual. We strongly recommend that you read shaper books, trade magazines, or get formal training to learn more about these.



SECTION 7: MAINTENANCE

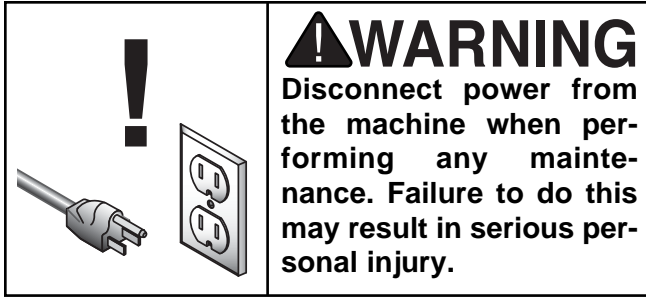

General

Regular periodic maintenance on your Model G0510 Shaper will ensure its optimum performance. Make a habit of inspecting your shaper each time you use it. Check for the following conditions and repair or replace when necessary.

1. Loose mounting bolts.
2. Worn switch.
3. Worn or damaged cords and plugs.
4. Damaged V-belt.
5. Any other condition that could hamper the safe operation of this machine.



Lubrication

The only parts on this machine that require periodic lubrication is where the spindle cartridge rides on the elevation housing. Use a light grease or anti-seizing compound on the ways. The frequency of lubrication depends on the amount you use the shaper. As a habit, inspect this area at least once a month.



Table

The table and other non-painted surfaces on the Model G0510 should be protected against rust and pitting. Wiping the table clean after every use ensures that moisture from wood dust is not allowed to trap moisture against bare metal surfaces.

Tables can be kept rust-free with regular applications of products like SLIPIT® or Boeshield® T-9. For long term storage you may want to consider products like Kleen Bore's Rust Guardit™.



Schedule

Regularly blow out hard to reach areas with compressed air and keep the spindle clear of wood dust and chips. Always wear a dust mask when using compressed air this way.

For every **1 hour** of use, clean and wipe down with Boeshield™ T-9 or SLIPIT®:

- Table and miter gauge slide
- Fence faces

For every **5 hours** of use, clean and oil:

- Offset adjustment mechanisms on fence

Once a year, replace the V-belt.



V-Belt Tension

You should be able to deflect the belt ¼" with moderate finger pressure. This may seem tight compared to most other V-Belts, but since the belt is small and runs fast, this much tension is necessary. The V-Belt will slip if too loose and squeal or cause vibration if too tight. Adjust the tension if necessary.

To adjust V-Belt tension:

1. Make sure the pulleys are properly aligned.
2. Loosen the two motor mount plate bolts and slide the motor left or right to modify the belt tension. Keep the pulleys aligned.
3. Tighten the motor mount plate bolts, test the tension, and check pulleys.
4. Repeat steps 2-3 until tension is correct, and pulleys are aligned.



SECTION 8: SERVICE ADJUSTMENTS

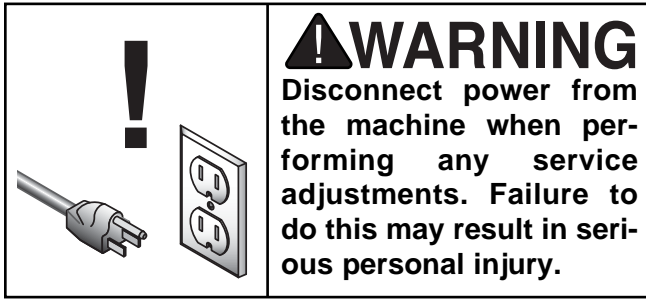

Pulley Alignment

Improper pulley alignment sharply reduces the effectiveness of power transmission and belt life expectancy.

To align the pulleys:

1. **Unplug shaper from the power source!**
2. Remove the spindle pulley cover.
3. Visually check the alignment of the V-belt while moving the spindle elevation through its full range of motion. If the motor pulley is in proper alignment with the spindle pulley, the V-belt should never move higher or lower than the upper and lower limits of the motor pulley.

—If the V-belt does move higher or lower than the upper or lower limits of the motor pulley, then the motor pulley must be adjusted.

4. You can align the motor pulley by raising or lowering it along the motor shaft. Loosen the setscrews and tap into the desired position with a dead blow hammer.



Spindle Bearings

The spindle bearing housing equipped with the Model G0510 features factory-sealed bearings. A sealed bearing requires no lubrication during its lifetime.

Should a bearing fail, your shaper will probably develop a noticeable rumble, which will increase when the machine is put under load. If allowed to get worse, overheating of the journal containing the bad bearing could occur. If the bad bearing is not replaced, it will eventually seize—possibly doing damage to other parts of the machine. Bearings are standard sizes and can be replaced through Grizzly.

You must remove the complete bearing housing assembly to replace the bearings.

To remove the bearing housing assembly:

1. **Unplug shaper from the power source!**
2. Take off the spindle pulley cover by removing the two mounting bolts shown in **Figure 27**.

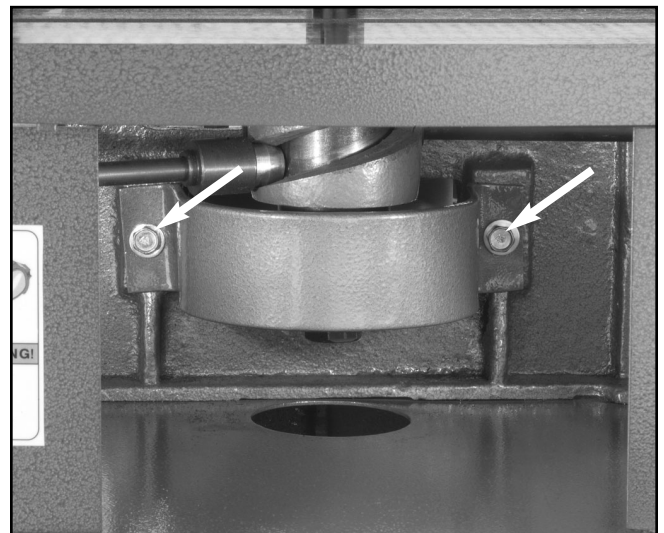

Figure 27. Spindle pulley cover mounting bolts.

3. Remove the two spindle nuts on the bottom of the spindle as shown in **Figure 28**.

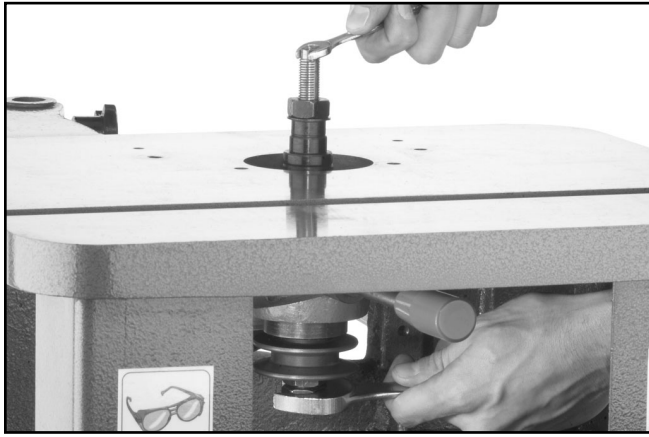

Figure 28. Loosening lower spindle nuts.

4. Remove the elevation handle by unthreading it counterclockwise.
5. Move the spindle up and down, and feel the spindle pulley hit against the bottom of the spindle housing bracket. Pull the spindle up with force to knock off the spindle pulley.
6. Pull the spindle straight up and out of the spindle housing.
7. Remove the retaining ring shown in **Figure 29**.

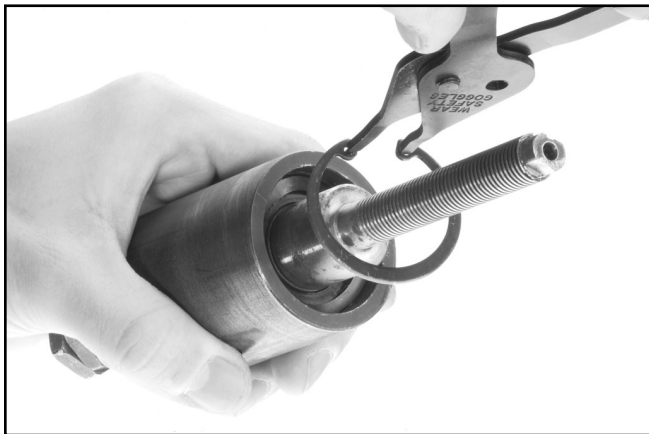

Figure 29. Removing bearing retaining ring.

8. Use a press to remove the bearings from the bracket housing. If you do not have access to a press, take the spindle assembly and your new bearings to a local machine shop and have them replace the bearings for you.
9. Spindle installation is the reverse of removal.

Truing The Fence

To ensure that the fence is parallel with itself and square with the table:

1. Ensure that the bolts through the wood facing on each side are tight and adequately countersunk.
2. To align the wood facing, adjust one or both fence halves so they are in close alignment. Micro-adjust and check the alignment with a straightedge.
3. If the wood fences are not coplanar with each other, resurface as one unit. You can perform this operation on a jointer as shown in **Figure 30**.

NOTICE

Make sure the screws are countersunk deep enough so the workpiece will not come in contact with the heads of the screws! Check the screw depth after each pass to ensure that the screws will not contact knives!

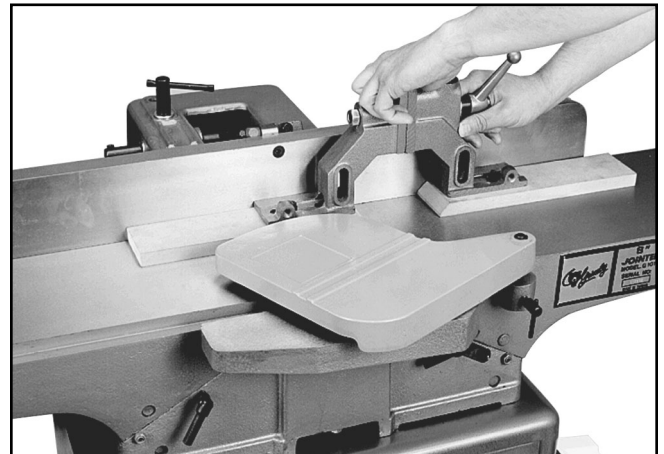

Figure 30. Resurfacing fences on a jointer.



SECTION 9: REFERENCE INFO

The following pages contain general machine data, parts diagrams/lists and Warranty/Return information for your Model G0510 3/4 HP Shaper.

If you need parts or help in assembling your machine, or if you need operational information, we encourage you to call our Service Department. Our trained service technicians will be glad to help you.

If you have comments dealing specifically with this manual, please write to our Bellingham, Washington location using the address in *Section 2: Introduction*. The specifications, drawings, and photographs illustrated in this manual represent the Model G0510 as supplied when the manual was prepared. However, due to Grizzly's policy of continuous improvement, changes may be made at any time with no obligation on the part of Grizzly. Whenever possible, though, we send manual updates to all owners of a particular tool or machine. Should you receive one, add the new information to this manual and keep it for reference.

We have included some important safety measures that are essential to this machine's operation. While most safety measures are generally universal, Grizzly reminds you that each workshop is different and safety rules should be considered as *they apply to your specific situation*.

We recommend you keep a copy of our current catalog for complete information regarding Grizzly's warranty and return policy. If you need additional technical information relating to this machine, or if you need general assistance or replacement parts, please contact the Service Department listed in *Section 3: Introduction*.

Additional information sources are necessary to realize the full potential of this machine. Trade journals, woodworking magazines, and your local library are good places to start.

WARNING

The Model G0510 was specifically designed for SHAPING. DO NOT modify and/or use this machine for any other purpose. Modifications or improper use of this tool will void the warranty. If you are confused about any aspect of this machine, DO NOT use it until you have answered all your questions. Serious personal injury may occur.





MACHINE DATA SHEET

Customer Service #: (570) 326-3806 • To Order Call: (800) 523-4777 • Fax #: (800) 438-5901

MODEL G0510 3/4 HP SHAPER

Design Type..... Floor Model

Overall Dimensions:

Table17³/₄" x15¹/₂"
Height (Includes Fence)37¹/₄"
Height From Table To Floor34¹/₄"
Width27"
Depth22"
Fence Boards2³/₄" x 11¹/₂" ea.
Weight (Shipping).....176 lbs.
Weight (in place)167 lbs.
Footprint18⁷/₈" x 16⁵/₈"

Capacities:

Spindle Sizes1/2"
Spindle Lengths2⁷/₈"
Spindle Travel.....7/8"
Spindle Capacity Under Nut2³/₈"
Table Counterbore2⁷/₈" x 3/8" Deep
Max. Cutter Diameter2⁷/₈"
Spindle Speeds8900 RPM
Spindle BearingsShielded, Permanently Lubricated Ball

Construction:

TableGround Cast Iron
Fence Assembly.....Cast Iron
Body AssemblyCast Iron
Base.....Pre-formed Steel

Motor:

TypeTEFC Capacitor-Start Induction
Horsepower3/4 HP
Phase / VoltageSingle-Phase / 110 V
SwitchReversible
Amps.....10
Cycle at RPM60 Hertz at 3450 RPM
BearingsSealed & Permanently Lubricated

Specifications, while deemed accurate, are not guaranteed.



G0510 110 VOLT WIRING DIAGRAM

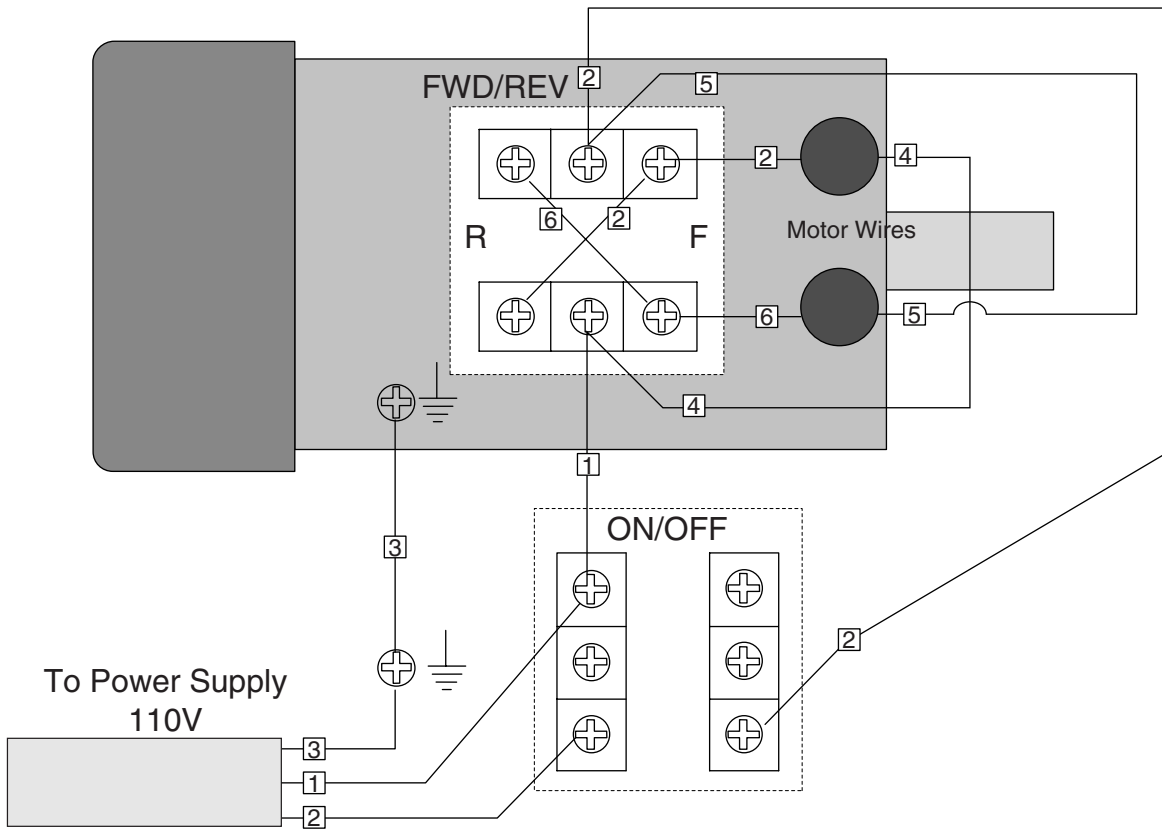

- 1 - WHITE
- 2 - BLACK
- 3 - GREEN
- 4 - GRAY
- 5 - BLUE
- 6 - RED

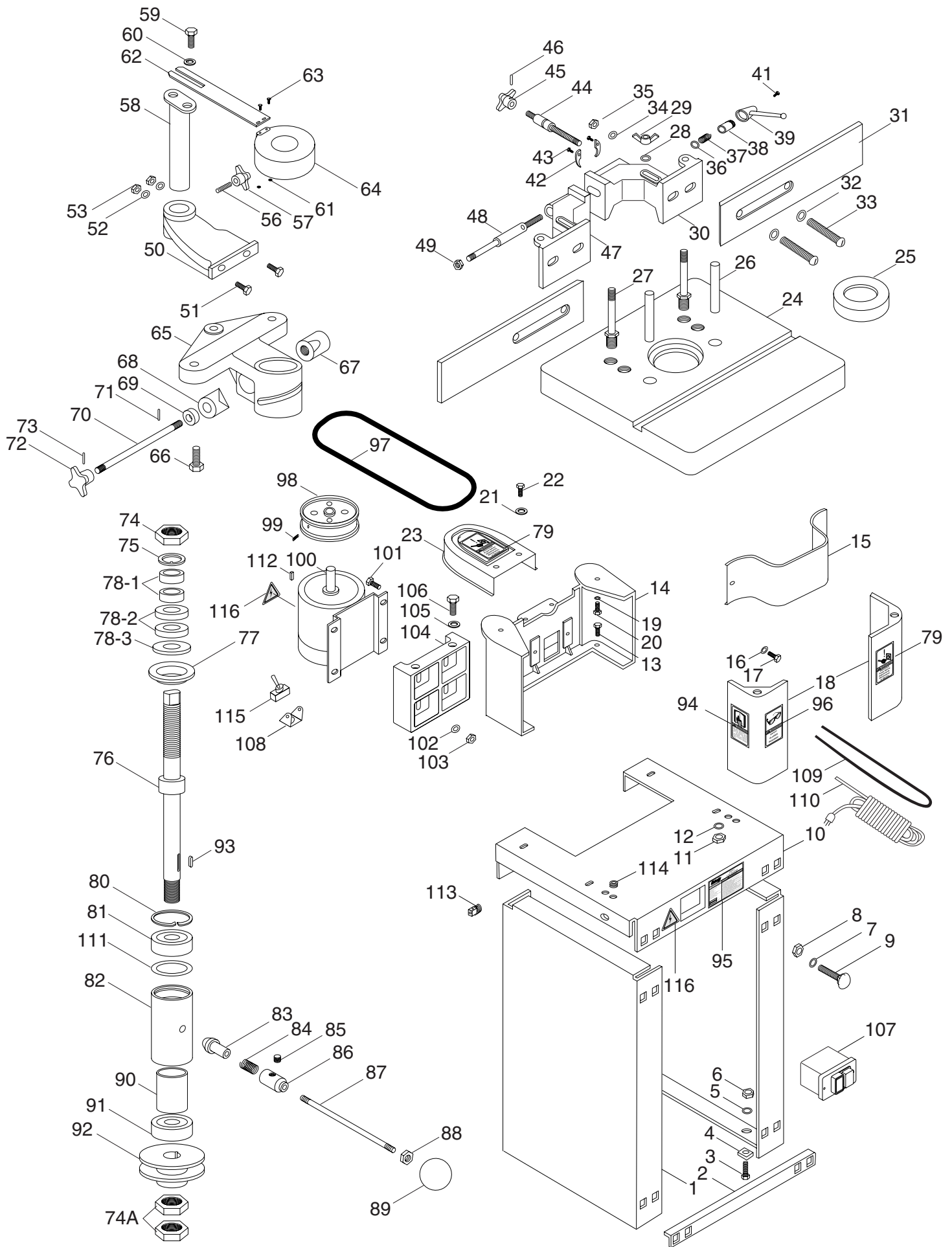

REF	PART #	DESCRIPTION
1	P0510003	SIDE PANEL
2	P0510002	TIE BAR
3	PB02M	HEX BOLT M6-1.0 X 12
4	P0510004	RUBBER FOOT
5	PW02	FLAT WASHER 3/8"
6	PN01M	HEX NUT M6-1.0
7	PW02	FLAT WASHER 3/8"
8	PN03M	HEX NUT M8-1.25
9	PCB06M	CARRIAGE BOLT M8-1.25 X 12
10	P0510010	SHELF
11	PN03M	HEX NUT M8-1.25
12	PW02	FLAT WASHER 3/8"
13	PB06M	HEX BOLT M8-1.25 X 12
14	P0510014	TABLE SUPPORT
15	P0510015	SPINDLE PULLEY GUARD
16	PW02	FLAT WASHER 3/8"
17	PB03M	HEX BOLT M8-1.25 X 16
18	P0510018	TABLE LEG
19	PW01	FLAT WASHER 1/2"
20	PB25M	HEX BOLT M12-1.75 X 25
21	PW02	FLAT WASHER 3/8"
22	PB06M	HEX BOLT M8-1.25 X 12
23	P0510023	BELT GUARD
24	P0510024	WORKING TABLE
25	P0510025	TABLE INSERT
26	P0510026	TAPER PIN
27	P0510027	CLAMP STUD
28	PW07	FLAT WASHER 5/16"
29	PWN03	WING NUT 5/16"-18
30	P0510030	FENCE BODY RIGHT
31	P0510031	WOODEN FENCE
32	PW06	FLAT WASHER 1/4"
33	P0510033	SLOT HEAD SCREW
34	PW07	FLAT WASHER 5/16"
35	PN03M	HEX NUT M8-1.25
36	PW01	FLAT WASHER 1/2"
37	P0510037	COIL SPRING
38	P0510038	SPRING COLLAR
39	P0510039	LOCK HANDLE
41	PS14M	PHIL HD SCREW M6-1.0 X 12
42	P0510042	HALF COLLAR
43	PSB26M	CAP SCREW M6-1.0 X 12
44	P0510044	ADJUSTING SCREW STUD
45	P0510045	HAND KNOB
46	PRP16M	ROLL PIN 3 X 25
47	P0510047	FENCE BODY LEFT
48	P0510048	CLAMP STUD
49	PN09M	HEX NUT M12-1.75
50	P0510050	MOUNTING BRACKET
51	PB26M	HEX BOLT M8-1.25 X 30
52	PW02	FLAT WASHER 3/8"
53	PN03M	HEX NUT M8-1.25
56	P0510056	STUD BOLT
57	P0510045	HAND KNOB
58	P0510058	HEX POST
59	PB06M	HEX BOLT M8-1.25 X 12
60	PW02	FLAT WASHER 3/8"
61	PN04M	HEX NUT M4-0.7

REF	PART #	DESCRIPTION
62	P0510062	HOLD DOWN BAR
63	PS02M	PHIL HD SCREW M4-0.7 X 12
64	P0510064	RING GUARD
65	P0510065	HOUSING BRACKET
66	PB27M	HEX BOLT M12-1.75 X 30
67	P0510067	CLAMP SLEEVE RIGHT
68	P0510068	CLAMP SLEEVE LEFT
69	P0510069	STUFF RING
70	P0510070	LOCK BAR
71	PRP02M	ROLL PIN 3 X 16
72	P0510045	HAND KNOB
73	PRP02M	ROLL PIN 3 X 16
74	P0510074	UPPER SPINDLE NUT
74A	P0510074A	LOWER SPINDLE NUT
75	P0510075	SAFETY WASHER
76	P0510076	CUTTER SPINDLE
77	P0510077	BEARING COVER
78-1	P051078-1	RUB COLLAR 1/2 X 1 X 3/8
78-2	P051078-2	RUB COLLAR 1/2 X 1 X 1/4
78-3	P051078-3	RUB COLLAR 1/2 X 1 X 3/16
79	PLABEL-26	UNPLUG MACHINE LABEL
80	PR23M	INT RETAINING RING 40MM
81	P6203	BALL BEARING 6203ZZ
82	P0510082	SPINDLE HOUSING
83	P0510083	BEARING CONE
84	P0510084	COIL SPRING
85	PSS20M	SETSCREW M8-1.25 X 8
86	P0510086	SPRING COLLAR
87	P0510087	STUD
88	PN06M	HEX NUT M5-.08
89	P0510089	KNOB
90	P0510090	COLLAR
91	P6203	BALL BEARING P6203ZZ
92	P0510092	SPINDLE PULLEY
93	PK14M	KEY 5 X 5 X 18
94	PLABEL-12	READ MANUAL LABEL
95	P0510095	ID/WARNING LABEL
96	PLABEL-11	SAFETY GLASSES LABEL
97	PVA30	V-BELT A-30
98	P0510098	MOTOR PULLEY
99	PSS04M	SETSCREW M6-1.0X12
100	P0510100	MOTOR
101	P0510101	CARRIAGE BOLT
102	PW02	FLAT WASHER 3/8"
103	PN03M	HEX NUT M8-1.25
104	P0510104	MOTOR MOUNT PLATE
105	PW01	FLAT WASHER 1/2"
106	PSB26M	CAP SCREW M6-1.0X12
107	P0510107	ON/OFF SWITCH
108	P0510108	SWITCH BRACKET
109	P0510109	WIRE CORD
110	P0510110	WIRE CORD
111	P0510111	WAVY WASHER
112	PK01M	KEY 5 X 5 X 22
113	P0510113	STRAIN RELIEF
114	P0510113	STRAIN RELIEF
115	P0510115	FWD/REV SWITCH
116	PLABEL-14	ELECTRICITY LABEL

REF	PART #	DESCRIPTION
117	PS19M	PHLP HD SCR M5-.8 X 6
118	P0510118	POINTER
119	P0510119	KNURLED KNOB
120	P0510120	FLAT WASHER
121	P0510121	MITER GAUGE BODY
122	P0510122	MITER BAR
123	PW06M	FLAT WASHER 12MM

REF	PART #	DESCRIPTION
124	PLW05M	LOCK WASHER 12MM
125	PLW04M	LOCK WASHER 8MM
126	PW01M	FLAT WASHER 8MM
127	PS08M	PHLP HD SCR M5-.0 X 12
128	PTLW02M	EXT TOOTH WASHER 5MM
129	P0510129	COMPLETE MITER GAUGE

WARRANTY AND RETURNS

Grizzly Industrial, Inc. warrants every product it sells for a period of **1 year** to the original purchaser from the date of purchase. This warranty does not apply to defects due directly or indirectly to misuse, abuse, negligence, accidents, repairs or alterations or lack of maintenance. This is Grizzly's sole written warranty and any and all warranties that may be implied by law, including any merchantability or fitness, for any particular purpose, are hereby limited to the duration of this written warranty. We do not warrant or represent that the merchandise complies with the provisions of any law or acts unless the manufacturer so warrants. In no event shall Grizzly's liability under this warranty exceed the purchase price paid for the product and any legal actions brought against Grizzly shall be tried in the State of Washington, County of Whatcom.

We shall in no event be liable for death, injuries to persons or property or for incidental, contingent, special, or consequential damages arising from the use of our products.

To take advantage of this warranty, contact us by mail or phone and give us all the details. We will then issue you a "Return Number," which must be clearly posted on the outside as well as the inside of the carton. We will not accept any item back without this number. Proof of purchase must accompany the merchandise.

The manufacturers reserve the right to change specifications at any time because they constantly strive to achieve better quality equipment. We make every effort to ensure that our products meet high quality and durability standards and we hope you never need to use this warranty.

Please feel free to write or call us if you have any questions about the machine or the manual.

Thank you again for your business and continued support. We hope to serve you again soon.

WARRANTY CARD

Name _____
 Street _____
 City _____ State _____ Zip _____
 Phone Number _____ E-Mail _____ FAX _____
MODEL #G0510 3/4 HP Shaper Order # _____

The following information is given on a voluntary basis. It will be used for marketing purposes to help us develop better products and services. Of course, all information is strictly confidential.

1. How did you learn about us?

<input type="checkbox"/> Advertisement	<input type="checkbox"/> Friend
<input type="checkbox"/> Catalog	<input type="checkbox"/> Card Deck
<input type="checkbox"/> World Wide Web	
<input type="checkbox"/> Other _____	
2. Which of the following magazines do you subscribe to.

<input type="checkbox"/> American Woodworker	<input type="checkbox"/> Practical Homeowner
<input type="checkbox"/> Cabinetmaker	<input type="checkbox"/> Shop Notes
<input type="checkbox"/> Family Handyman	<input type="checkbox"/> Today's Homeowner
<input type="checkbox"/> Fine Homebuilding	<input type="checkbox"/> WOOD
<input type="checkbox"/> Fine Woodworking	<input type="checkbox"/> Wooden Boat
<input type="checkbox"/> Home Handyman	<input type="checkbox"/> Woodshop News
<input type="checkbox"/> Journal of Light Construction	<input type="checkbox"/> Woodsmith
<input type="checkbox"/> Old House Journal	<input type="checkbox"/> Woodwork
<input type="checkbox"/> Popular Mechanics	<input type="checkbox"/> Woodworker
<input type="checkbox"/> Popular Science	<input type="checkbox"/> Woodworker's Journal
<input type="checkbox"/> Popular Woodworking	<input type="checkbox"/> Workbench
<input type="checkbox"/> Other _____	
3. Which of the following woodworking/remodeling shows do you watch?

<input type="checkbox"/> Backyard America	<input type="checkbox"/> The New Yankee Workshop
<input type="checkbox"/> Home Time	<input type="checkbox"/> This Old House
<input type="checkbox"/> The American Woodworker	<input type="checkbox"/> Woodwright's Shop
<input type="checkbox"/> Other _____	
4. What is your annual household income?

<input type="checkbox"/> \$20,000-\$29,999	<input type="checkbox"/> \$60,000-\$69,999
<input type="checkbox"/> \$30,000-\$39,999	<input type="checkbox"/> \$70,000-\$79,999
<input type="checkbox"/> \$40,000-\$49,999	<input type="checkbox"/> \$80,000-\$89,999
<input type="checkbox"/> \$50,000-\$59,999	<input type="checkbox"/> \$90,000 +
5. What is your age group?

<input type="checkbox"/> 20-29	<input type="checkbox"/> 50-59
<input type="checkbox"/> 30-39	<input type="checkbox"/> 60-69
<input type="checkbox"/> 40-49	<input type="checkbox"/> 70 +
6. How long have you been a woodworker?

<input type="checkbox"/> 0 - 2 Years	<input type="checkbox"/> 8 - 20 Years
<input type="checkbox"/> 2 - 8 Years	<input type="checkbox"/> 20+ Years
7. How would you rank your woodworking skills?

<input type="checkbox"/> Simple	<input type="checkbox"/> Advanced
<input type="checkbox"/> Intermediate	<input type="checkbox"/> Master Craftsman
8. What stationary woodworking tools do you own? Check all that apply.

<input type="checkbox"/> Air Compressor	<input type="checkbox"/> Panel Saw
<input type="checkbox"/> Band Saw	<input type="checkbox"/> Planer
<input type="checkbox"/> Drill Press	<input type="checkbox"/> Power Feeder
<input type="checkbox"/> Drum Sander	<input type="checkbox"/> Radial Arm Saw
<input type="checkbox"/> Dust Collector	<input type="checkbox"/> Shaper
<input type="checkbox"/> Horizontal Boring Machine	<input type="checkbox"/> Spindle Sander
<input type="checkbox"/> Jointer	<input type="checkbox"/> Table Saw
<input type="checkbox"/> Lathe	<input type="checkbox"/> Vacuum Veneer Press
<input type="checkbox"/> Mortiser	<input type="checkbox"/> Wide Belt Sander
<input type="checkbox"/> Other _____	
9. How many of your woodworking machines are Grizzly? _____
10. Which benchtop tools do you own? Check all that apply.

<input type="checkbox"/> 1" x 42" Belt Sander	<input type="checkbox"/> 6" - 8" Grinder
<input type="checkbox"/> 5" - 8" Drill Press	<input type="checkbox"/> Mini Lathe
<input type="checkbox"/> 8" Table Saw	<input type="checkbox"/> 10" - 12" Thickness Planer
<input type="checkbox"/> 8" - 10" Bandsaw	<input type="checkbox"/> Scroll Saw
<input type="checkbox"/> Disc/Belt Sander	<input type="checkbox"/> Spindle/Belt Sander
<input type="checkbox"/> Mini Jointer	
<input type="checkbox"/> Other _____	
11. How many of the machines checked above are Grizzly? _____
12. Which portable/hand held power tools do you own? Check all that apply.

<input type="checkbox"/> Belt Sander	<input type="checkbox"/> Orbital Sander
<input type="checkbox"/> Biscuit Joiner	<input type="checkbox"/> Palm Sander
<input type="checkbox"/> Circular Saw	<input type="checkbox"/> Portable Planer
<input type="checkbox"/> Detail Sander	<input type="checkbox"/> Saber Saw
<input type="checkbox"/> Drill/Driver	<input type="checkbox"/> Reciprocating Saw
<input type="checkbox"/> Miter Saw	<input type="checkbox"/> Router
<input type="checkbox"/> Other _____	
13. What machines/supplies would you like Grizzly Industrial to carry?

<input type="checkbox"/> 12" Table Saw	<input type="checkbox"/> Radial Arm Saw
<input type="checkbox"/> 12" Jointer	<input type="checkbox"/> Panel Saw
<input type="checkbox"/> Combination Planer/Jointer	<input type="checkbox"/> Brass Hardware
<input type="checkbox"/> Paint & Finishing Supplies	<input type="checkbox"/> Lumber
<input type="checkbox"/> Contractor's Supplies	
<input type="checkbox"/> Other _____	
14. What new accessories would you like Grizzly Industrial to carry?

<input type="checkbox"/> Builders Hardware	<input type="checkbox"/> Hand Tools
<input type="checkbox"/> Fasteners	<input type="checkbox"/> Wood Components
<input type="checkbox"/> Other _____	
15. What other companies do you purchase your tools and supplies from?

16. Do you think your purchase represents good value?

<input type="checkbox"/> Yes	<input type="checkbox"/> No
------------------------------	-----------------------------
17. Would you recommend Grizzly Imports to a friend?

<input type="checkbox"/> Yes	<input type="checkbox"/> No
------------------------------	-----------------------------
18. Would you allow us to use your name as a reference for Grizzly customers in your area? **Note: We never use names more than three times.**

<input type="checkbox"/> Yes	<input type="checkbox"/> No
------------------------------	-----------------------------
19. Comments: _____

CUT ALONG DOTTED LINE

FOLD ALONG DOTTED LINE



Place
Stamp
Here

Grizzly
Industrial, Inc.[®]
GRIZZLY INDUSTRIAL, INC.
P.O. BOX 2069
BELLINGHAM, WA 98227-2069



FOLD ALONG DOTTED LINE

Send a Grizzly Catalog to a friend:

Name _____
Street _____
City _____ State _____ Zip _____

TAPE ALONG EDGES--PLEASE DO NOT STAPLE

grizzly.com

TOOL WEBSITE

Buy Direct and Save with Grizzly® – Trusted, Proven and a Great Value!

*Visit Our Website Today And Discover Why
Grizzly® Is The Industry Leader!*

- SECURE ORDERING
- ORDERS SHIPPED WITHIN 24 HOURS
- E-MAIL RESPONSE WITHIN ONE HOUR

-OR-

Call Today For A **FREE**
Full Color Catalog

1-800-523-4777

