

MODEL W1683 20" PLANER



INSTRUCTION MANUAL

Phone: 1-360-734-3482 • On-Line Technical Support: tech-support@woodstockint.com

COPYRIGHT © April, 2002 BY WOODSTOCK INTERNATIONAL, INC.

WARNING: NO PORTION OF THIS MANUAL MAY BE REPRODUCED IN ANY SHAPE OR FORM WITHOUT
THE WRITTEN APPROVAL OF WOODSTOCK INTERNATIONAL, INC.

Printed in Taiwan

WARNING

Some dust created by power sanding, sawing, grinding, drilling, and other construction activities contains chemicals known to the State of California to cause cancer, birth defects or other reproductive harm. Some examples of these chemicals are:

- Lead from lead-based paints.
- Crystalline silica from bricks, cement, and other masonry products.
- Arsenic and chromium from chemically treated lumber.

Your risk from these exposures varies, depending on how often you do this type of work. To reduce your exposure to these chemicals: work in a well ventilated area, and work with approved safety equipment, such as those dust masks that are specially designed to filter out microscopic particles.

Table Of Contents

	PAGE
1. INTRODUCTION	2
ABOUT YOUR NEW PLANER	2
WOODSTOCK SERVICE AND SUPPORT	2
WARRANTY AND RETURNS	3
PLANER MACHINE SPECIFICATIONS	3
2. SAFETY FIRST!	4
SAFETY INSTRUCTIONS	4-5
ADDITIONAL SAFETY INSTRUCTIONS FOR PLANERS	6
ELECTRICAL REQUIREMENTS	7
220V OPERATION	7
EXTENSION CORDS	7
GROUNDING	7
3. ASSEMBLY	8
BOX CONTENTS	8
OVERVIEW	8
SHOP PREPARATION	9
CLEANING MACHINE	9
EXTENSION ROLLERS	10
HANDWHEEL	11
DUST HOOD	11
SWITCH	12
KNIFE SETTING JIG	12
4. ADJUSTMENTS	13
LOCATION OF CONTROLS	13
MOVING BED ROLLERS	14
TABLE	14-16
CHECKING KNIVES	17
KNIFE ADJUSTMENT	18-19
FEED ROLLERS, CHIPBREAKER & PRESSURE BAR	20-21
CHIP DEFLECTOR	22
ANTI-KICKBACK PAWLS	22
CHAIN TENSIONER	23
SPRING TENSION	23
TABLE ROLLERS	24
5. OPERATIONS	25
TEST RUN	25
FEED RATE	25
OPERATIONAL TIPS	26
TROUBLESHOOTING PLANING RESULTS	27
AFTERMARKET SETUP ACCESSORIES	28
6. MAINTENANCE	29
GENERAL	29
CLEANING	29
TABLE AND BASE	29
LUBRICATION	30
BELT TENSION	31
PULLEY ALIGNMENT	31
WIRING DIAGRAM	32
TROUBLESHOOTING	33
7. CLOSURE	34
DIAGRAMS AND PARTS LISTS	35-42
WARRANTY AND REPLACEMENT	43

USE THE QUICK GUIDE PAGE LABELS TO SEARCH OUT INFORMATION FAST!





INTRODUCTION

ABOUT YOUR NEW PLANER

This new Shop Fox® 20" Planer has been specially designed to provide many years of trouble free service. Close attention to detail, ruggedly built parts and a rigid quality control program assure safe and reliable operation.

Woodstock International, Inc. is committed to customer satisfaction in providing this manual. It is our intent to make sure all the information necessary for safety, ease of assembly, practical use and durability of this product be included.

If you should have any comments regarding this manual, please contact us at:

Woodstock International, Inc.
P.O. Box 2309
Bellingham, WA 98227

WOODSTOCK SERVICE AND SUPPORT

We stand behind our machines! In the event that a defect is found, parts are missing or questions arise about your machine, please contact Woodstock International Service and Support at 1-360-734-3482 or tech-support@woodstockint.com. Our knowledgeable staff will help you troubleshoot problems, send out parts or arrange warranty repair or returns.

WARRANTY AND RETURNS

Woodstock International, Inc. warrants all SHOP FOX® machinery to be free of defects from workmanship and materials for a period of 2 years from the date of original purchase by the original owner. This warranty does not apply to defects due directly or indirectly to misuse, abuse, negligence or accidents, lack of maintenance, or to repair or alterations made or specifically authorized by anyone other than Woodstock International, Inc.

Woodstock International, Inc. will repair or replace, at its expense and at its option, the SHOP FOX® machine or machine part which in normal use has proven to be defective, provided that the original owner returns the product prepaid to the SHOP FOX® factory service center or authorized repair facility designated by our Bellingham, WA office, with proof of their purchase of the product within 2 years, and provides Woodstock International, Inc. reasonable opportunity to verify the alleged defect through inspection. If it is determined there is no defect, or that the defect resulted from causes not within the scope of Woodstock International Inc.'s warranty, then the original owner must bear the cost of storing and returning the product.

This is Woodstock International, Inc.'s sole written warranty and any and all warranties that may be implied by law, including any merchantability or fitness, for any particular purpose, are hereby limited to the duration of this written warranty. We do not warrant that SHOP FOX® machinery complies with the provisions of any law or acts. In no event shall Woodstock International, Inc.'s liability under this warranty exceed the purchase price paid for the product, and any legal actions brought against Woodstock International, Inc. shall be tried in the State of Washington, County of Whatcom. We shall in no event be liable for death, injuries to persons or property or for incidental, contingent, special or consequential damages arising from the use of our products.

Every effort has been made to ensure that all SHOP FOX® machinery meets high quality and durability standards. We reserve the right to change specifications at any time because of our commitment to continuously improve the quality of our products.

Planer Machine Specifications

Motor	5 H.P., 220V, Single-Phase
Amps	28
Cutting Width	20"
Cutting Height	8"
Minimum Stock Thickness	1/4"
Minimum Stock Length	7"
Maximum Depth of Cut	1/8"
Cutterhead Diameter	3 ³ / ₁₆ "
Cutterhead Speed	5500 R.P.M.
Table Size	25 ³ / ₄ " x 20"
Knives	4 H.S.S.
Feed Rates	18 & 23 F.P.M.

SAFETY FIRST!

READ MANUAL BEFORE OPERATING MACHINE FAILURE TO FOLLOW INSTRUCTIONS BELOW WILL RESULT IN PERSONAL INJURY



Indicates an imminently hazardous situation which, if not avoided, **WILL** result in death or serious injury.



Indicates a potentially hazardous situation which, if not avoided, **COULD** result in death or serious injury.



Indicates a potentially hazardous situation which, if not avoided, **MAY** result in minor or moderate injury. It may also be used to alert against unsafe practices.

NOTICE

This symbol is used to alert the user to useful information about proper operation of the equipment.

1. **Thoroughly read the instruction manual before operating your machine.** Learn the applications, limitations and potential hazards of this machine. Keep manual in a safe, convenient place for future reference.
2. **Keep work area clean and well lighted.** Clutter and inadequate lighting invite potential hazards.
3. **Ground all tools.** If a machine is equipped with a three-prong plug, it must be plugged into a three-hole electrical outlet or grounded extension cord. If using an adapter to aid in accommodating a two-hole receptacle, ground using a screw to a known ground.
4. **Wear eye protection at all times.** Use safety glasses with side shields or safety goggles (that meet the national safety standards) while operating this machine.
5. **Avoid dangerous environments.** Do not operate this machine in wet or open flame environments. Airborne dust particles could cause an explosion and severe fire hazard.
6. **Ensure all guards are securely in place and in working condition.**
7. **Make sure switch is in the "OFF" position** before connecting power to machine.
8. **Keep work area clean and free of clutter, grease, etc.**
9. **Keep children and visitors away.** All visitors should be kept a safe distance away while operating unit.
10. **Childproof workshop** with padlocks, master switches or by removing switch keys.
11. **Disconnect machine when cleaning, adjusting or servicing.**
12. **Do not force tool.** The machine will do a safer and better job at the rate for which it was designed.

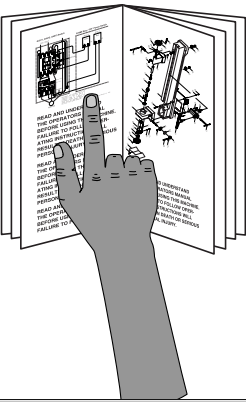
13. **Use correct tool.** Do not force machine or attachment to do a job for which it was not designed.
14. **Wear proper apparel.** Do not wear loose clothing, neck ties, gloves, jewelry, etc.
15. **Remove adjusting keys and wrenches** before turning the machine on. Make this a habit!
16. **Use proper extension cord.** When using an extension cord, make sure it is in good condition. Use extension cords 100' or less in length that are rated Hard Service (grade 5) or better, and that have a conductor size of 16 A.W.G. A drop in line voltage, loss of power and overheating can result when using an undersized cord. The extension cord must have a ground wire and ground plug pin, as well.
17. **Keep proper footing and balance** at all times.
18. **Do not leave machine unattended**—wait until it comes to a complete stop before leaving the area.
19. **Perform machine maintenance and care.** Follow lubrication and accessory attachment instructions in the manual.
20. **Keep machine away from open flame.** Operating machines near pilot lights and/or open flames creates a high risk if dust is dispersed in the area. Dust particles and an ignition source may cause an explosion. Do not operate the machine in high risk areas, including but not limited to, those mentioned above.
21. **Do not use machine under the influence of drugs or alcohol or if you are excessively tired.**
22. **Do not let untrained people use the machine if they are not supervised by an experienced operator.**
23. **If at any time you are experiencing difficulties performing the intended operation, stop using the machine!** Then contact our service department or ask a qualified expert how the operation should be performed.
24. **Mag switches can be accidentally turned on when they are bumped.** Always be aware of the mag switch location when moving items around the shop.

WARNING		
<p>Operating this equipment has the potential for flying debris to cause eye injury. Always wear safety glasses or goggles when operating equipment. Everyday glasses or reading glasses only have impact resistant lenses, they are not safety glasses. Be certain the safety glasses you wear meet the appropriate standards of the American National Standards Institute (ANSI).</p>		

ADDITIONAL SAFETY INSTRUCTIONS FOR PLANERS

SAFETY

1. **Always** make sure the planer is on firm ground and is stable before operating. Immediately fix or shim the planer if it rocks or wobbles.
2. **Always** inspect the workpiece before running it through the planer. Stock with loose knots, nails, staples, dirt or other foreign objects should be rejected from use or corrected by eliminating the condition that makes it questionable.
3. **Always** make sure that all components of the planer are adjusted to their proper specifications before planing stock.
4. **Always** use the help of another person or some type of support fixture when planing long stock.
5. **Never** stand behind the workpiece when you are feeding it into the planer; the workpiece could possibly kick back and be thrown in the direction from which it came.
6. **Never** operate the planer if knives are dull or damaged. Sharp knives are safer and produce better final results.
7. **Never** process any material through the planer other than wood. This planer is designed for wood only!
8. **Always** take multiple light cuts rather than excessively deep cuts.
9. **Never** attempt to free a stalled workpiece while the planer is powered on and plugged in.
10. **Absolutely never** reach inside the planer or open the top cover while the planer is powered on and/or plugged in.
11. **Never** plane wood that is less than 7" long or less than 1/4" thick.
12. **Always** wear hearing protection when operating the planer.



! WARNING
Read the manual completely before assembly and operation. Become familiar with the machine and its operation before beginning any work. Serious personal injury may result if safety or operational information is not understood or followed.

! CAUTION
No list of safety guidelines can be complete. Every shop environment is different. Always consider safety first, as it applies to your individual working conditions. Use this and other machinery with caution and respect. Failure to do so could result in serious personal injury, damage to equipment or poor work results.

ELECTRICAL REQUIREMENTS

SAFETY

NOTICE

NEVER replace the circuit breaker with one rated at a higher amperage or damage to the circuit may occur.

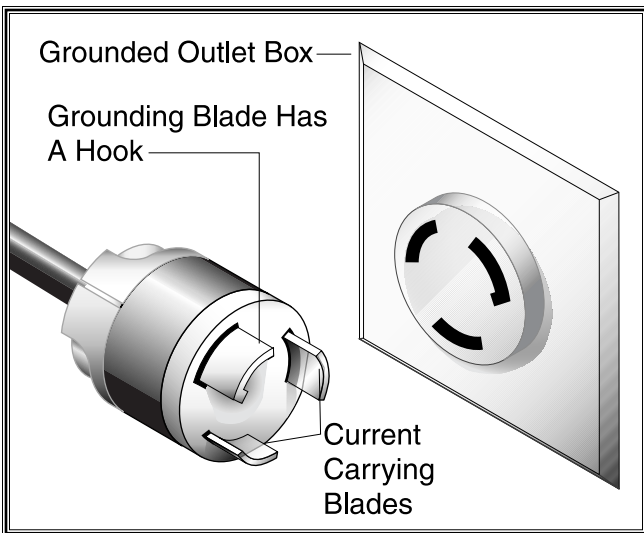
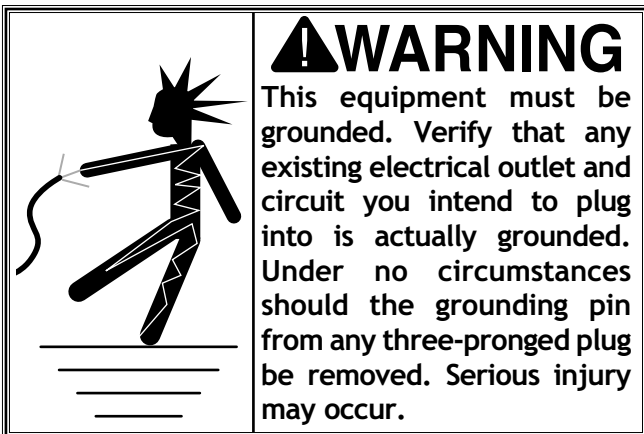


Figure 1. Typical 220V 3-prong plug and outlet.

220V Operation

The motor supplied with your new planer is rated at 5 H.P. and will draw approximately 28 amps during 220 volt operation. When choosing an outlet for this machine, we recommend using a NEMA L6-30A with a 30 amp circuit breaker or fuse. Keep in mind that a circuit being used by other machines or tools at the same time will add to the total load being applied to the circuit. Add up the load ratings of all machines on the circuit. If this number exceeds the rating of the circuit breaker, fuse or wires, use a different circuit.

Extension Cords

We do not recommend using an extension cord for 220V equipment. Instead, arrange the placement of your machinery and installed wiring to eliminate the need for extension cords. If you must use an extension cord, make sure it is rated Hard Service (grade 5) and capable of handling a 28 amp load. The extension cord must always contain a ground wire and plug pin. Be sure to ask an expert about the correct gauge to use with your desired cord length. Always repair or replace extension cords when they become worn or damaged.

Grounding

This machine must be grounded! **See Figure 1.** The electrical cord supplied with the Model W1683 does not come with a 220 volt plug. Use a plug with a ground pin. If your outlet does not accommodate a ground pin, have it replaced by a qualified electrician or have an appropriate adapter installed and grounded properly. An adapter with a grounding wire does not guarantee the machine will be grounded. A ground source must be verified.

ASSEMBLY

The following is a description of the components shipped with the Shop Fox® W1683 20" Planer.

Should any parts be missing, examine the packaging carefully to be sure parts are not among the packing materials. If any key parts are missing, contact Woodstock International, Inc. at 360-734-3482 or by e-mail at: tech-support@woodstockint.com.

Box Contents

1. Planer Unit
2. Dust Hood
3. Starter Switch
4. Rollers (2)
5. Handwheel
6. Hardware Bag:
 - (6) M6-1.0 x 12 Hex Bolts
 - (6) 6mm Flat Washers
 - (8) 1/2" Flat Washers
 - (8) M10-1.5 x 25 Hex Bolts
 - (1) Knife Setting Rod
 - (2) Knife Setting Gauge
 - (4) 9mm E-Clip Ring
 - (1) Handle
 - (1) 3mm Allen Wrench
 - (1) 4mm Allen Wrench
 - (1) 5mm Allen Wrench
 - (1) 6mm Allen Wrench
 - (1) 8mm & 10mm Combo Wrench
 - (1) 12mm & 14mm Combo Wrench
 - (1) 17mm & 19mm Combo Wrench

Overview

We have assembled most of your new planer for you at the factory; however, the parts shown in **Figure 2** still need to be assembled after delivery. Please take your time and try to be as accurate as possible when following each step. This care will provide you with better results when you are finished.

Additional Tools Required: Besides the tools that were included with the planer, you will also need a Phillips® screwdriver, a flat-head screwdriver and a good straightedge. A set of feeler gauges and a dial indicator will also be necessary for the *Adjustments* section.

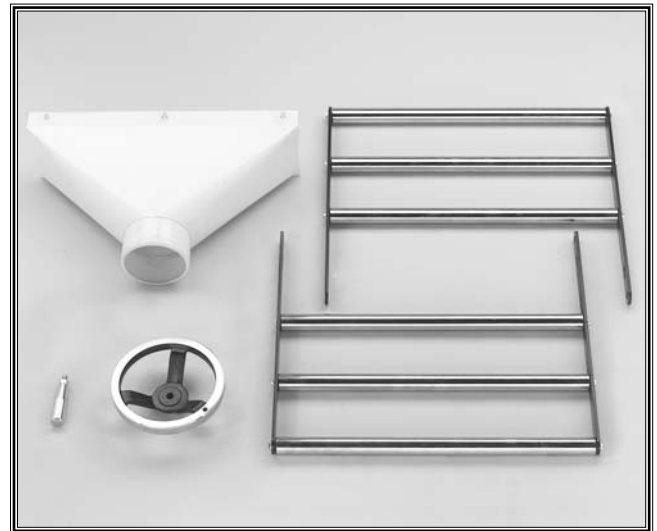
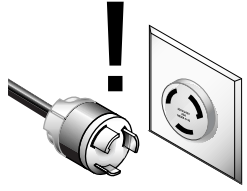


Figure 2. Parts that need to be assembled.



⚠ WARNING

Do not connect the machine to power at this time. The machine must remain unplugged throughout the entire assembly process. Failure to do this may result in serious personal injury.

Shop Preparation

- **Floor Load:** Your Model W1683 represents a large weight load in a small footprint. Most commercial floors are suitable for the planer. Some residential floors may require additional bracing to support both machine and operator.
- **Working Clearances:** Consider existing and anticipated needs, size of material to be processed through each machine, and space for auxiliary stands, work tables or other machinery when establishing a location for your planer.
- **Lighting and Outlets:** Lighting should be bright enough to eliminate shadow and prevent eye strain. Electrical circuits should be dedicated or large enough to handle amperage requirements. Outlets should be located near each machine so power or extension cords are clear of high-traffic areas. Observe local electrical codes for proper installation of new lighting, outlets, or circuits.

	<p>! WARNING</p> <p>The Model W1683 is a heavy machine, 840 lbs. shipping weight. Use power equipment. Serious personal injury may occur if safe moving methods are not followed.</p>
--	--

	<p>! CAUTION</p> <p>Make your shop “child safe.” Ensure that your workplace is inaccessible to youngsters by closing and locking all entrances when you are away. Never allow visitors in your shop when assembling, adjusting or operating equipment.</p>
--	---

Cleaning Machine

The table and other unpainted parts of the Model W1683 are coated with a waxy grease that protects them from corrosion during shipment. Clean this grease off with a solvent cleaner or citrus-based degreaser. Do not use chlorine-based solvents—if you happen to splash some onto a painted surface, you will ruin the finish.

	<p>! WARNING</p> <p>Do not use gasoline or other petroleum-based solvents. They have low flash points which make them extremely flammable. A risk of explosion and burning exists if these products are used. Serious personal injury may occur if this warning is ignored.</p>
--	--

	<p>! WARNING</p> <p>Do not smoke while using solvents. A risk of explosion or fire exists and may result in serious personal injury.</p>
--	---

	<p>! CAUTION</p> <p>Many of the solvents commonly used to clean machinery can be toxic when inhaled or ingested. Always work in well-ventilated areas far from potential ignition sources when dealing with solvents. Use care when disposing of waste rags and towels to be sure they do not create fire or environmental hazards.</p>
--	--

ASSEMBLY

Extension Rollers

The extension roller assemblies are identical for both the infeed and the outfeed ends of the table. To mount these assemblies:

1. Attach an extension bar to the end of each roller. Secure these in place with the 12mm snap rings provided in the hardware bag.
2. Match the tapped holes on the side of the table to the extension bars. Lightly secure in place with the M10-1.5 x 25 hex bolts and washers from the hardware bag.
3. The end (outside) roller is fixed in place. Place a straightedge flat across the table and across the rollers as shown in **Figure 3**. Adjust the end roller so it is flush with the table, and tighten the M10-1.5 x 25 hex bolts to secure the extension bars in place.
4. The two inside rollers are mounted in slotted holes so they can be adjusted flush with the table and the end roller. Make these adjustments and tighten the bolts to secure the inside rollers in place.

The top of the rollers should now be completely even with the top of the table. Double-check to make sure that the rollers did not move during the tightening process.

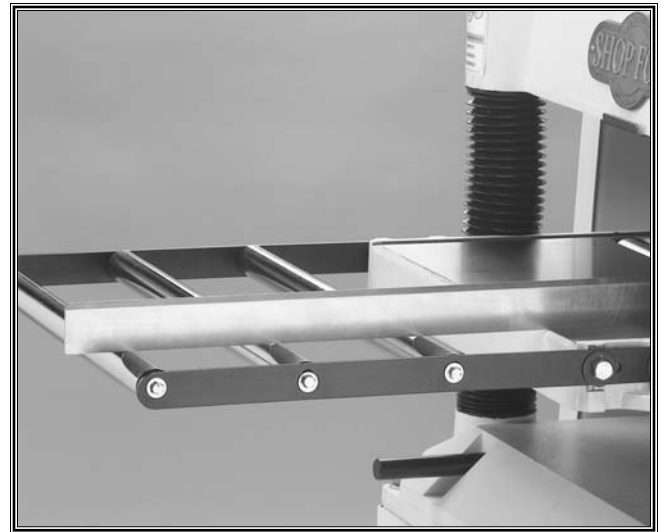


Figure 3. Checking roller extension with a straightedge.



Figure 4. Handwheel attached correctly.



Figure 5. Dust hood attached to planer.

Handwheel

The handwheel operates the chain driven system that raises/lowers the table to control the cutting depth.

To mount the handwheel:

1. Secure the handwheel to the worm gear shaft (as shown in **Figure 4**) with the hex nut and washer that is already on the threads.
2. Thread the handle into the handwheel and tighten the hex nut to keep it locked in place.

Dust Hood

The dust hood included should only be installed if you plan on hooking your planer up to a dust collection system.

To install the dust hood:

1. Match the holes in the dust hood to the tapped holes in the planer casting on the outfeed end.
2. Secure the dust hood with the (6) M6-1.0 x 12 hex bolts from the hardware bag, as shown in **Figure 5**.
3. Attach a 5" dust hose to the dust port.

Switch

The prewired magnetic switch needs to be mounted to the planer head casting.

To mount the switch:

1. Match the holes at the back of the switch with the tapped holes in the front, left-hand corner of the planer.
2. Secure the switch to the head casting with the cap screws as shown in **Figure 6**.
3. Read *Section 2: Circuit Requirements* in this manual, then install an appropriate plug to the power wire.



Figure 6. Attaching switch to the planer.

	<p>! WARNING DO NOT connect machine to the power at this time! Wait until all other assembly instructions and adjustments have been completed.</p>
--	---

Knife Setting Jig

We have provided a jig to make the knife setting process easy and quick. Please refer to **Figure 7** for jig component identification while assembling.

To assemble the knife setting jig:

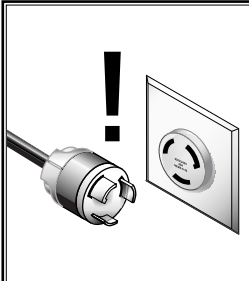
1. Snap one of the E-clips over the notch on one end of the knife setting rod.
2. Slide the aluminum knife setting jig brackets onto the rod.
3. Snap the other E-clip on the other end of the knife setting rod.

Refer to page 17 for use.

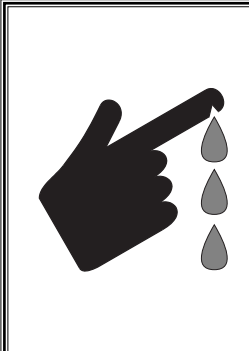


Figure 7. Knife setting jig.

ADJUSTMENTS



⚠️ WARNING
Do not connect power to the machine while performing adjustments. Failure to follow this warning may result in serious personal injury.



⚠️ CAUTION
Planer knives are dangerously sharp! Use extreme caution when working near cutting surfaces. Failure to exercise care while working near knives could result in severe injury.

Location of Controls

Take the time to familiarize yourself with the controls of your new planer. They will be frequently mentioned throughout the instructions in this manual, and the better you know your machine, the better you can make it perform. **Figure 8** points out the key controls and their locations.

As with all precision machinery, adjustments to the planer require very close tolerances. The adjustments described in this section will be factory set. However, during the life of the machine it will necessary to make these adjustments yourself. Many of these adjustments require the use of an indicating tool such as a dial indicator or a Rotacator[®] to achieve accurate results.

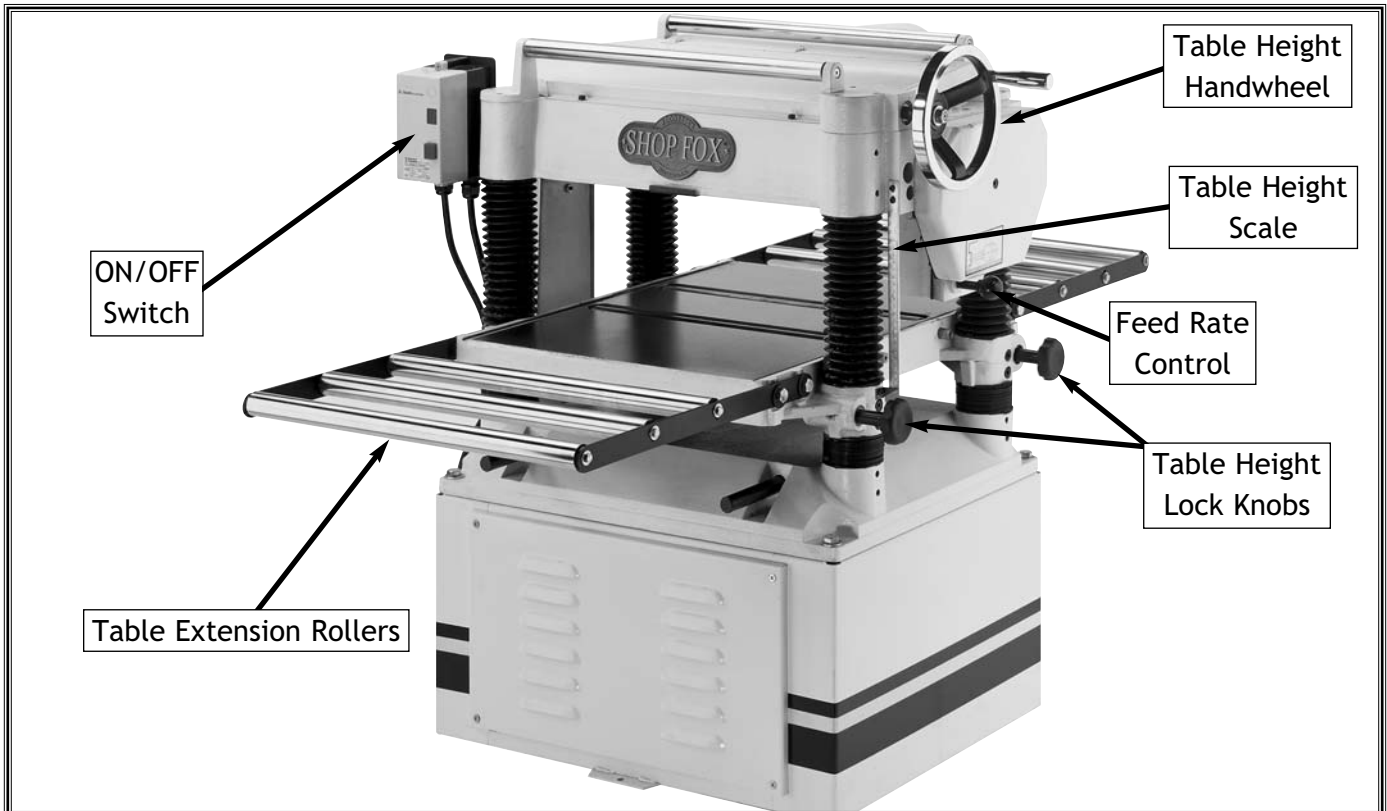


Figure 8. Machine controls.

ADJUSTMENTS

Moving Bed Rollers

In order to perform table adjustments, the bed rollers must be adjusted below the surface of the table.

To move the bed rollers:

1. Loosen the setscrews where the bed rollers mount to the planer body (on both ends) as shown in **Figure 9**.
2. Use a wrench to lower the rollers on their eccentric shafts.

Leave the bed rollers in this position until instructed to adjust them at the end of this section.

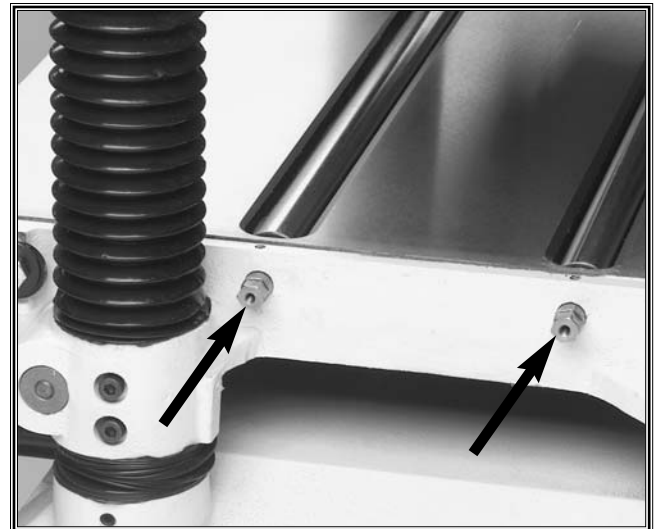


Figure 9. Bed roller setscrews.

Table

The most critical adjustments made on your new planer are dependent on the table being parallel to the cutterhead body. Because of this relationship, checking the table is the first step to setting up an accurate planer.

There are two movements you should be concerned about when checking/adjusting the table—the table should be parallel to the head casting from front-to-back, and the table should be parallel with the cutterhead body from side-to-side.

The table has been pre-set at the factory, but it is a good idea to check any machine thoroughly before use.

To check the table:

1. **Make sure machine is unplugged!**
2. Make the gauge shown in **Figure 10** out of a block of wood.

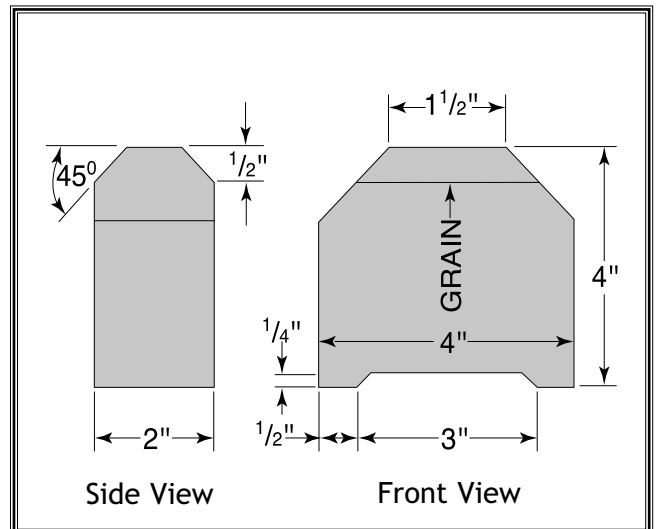


Figure 10. Gauge block.



Figure 11. Checking table/head casting in front.

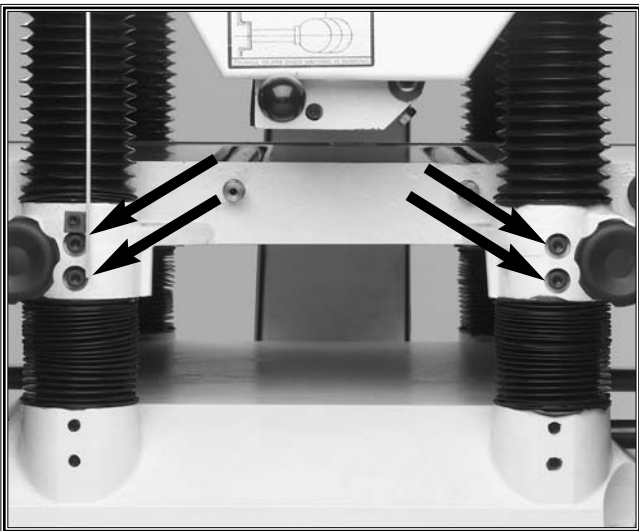


Figure 12. Table mounting screws.

3. Place the block on one end of the table, directly under the cutterhead body. Raise the table up so the block only touches the cutterhead body (keep knives rotated out of the way for this step).
4. Without moving the table, slide the block of wood to the other end of the cutterhead. If the block of wood will not fit, or if the block is below the cutterhead body, measure this gap with a feeler gauge. If the difference is more than .002", then the table needs to be adjusted from left to right.
5. Place the block under the middle-front of the head casting. Raise the table up so the block barely touches the head casting as shown in Figure 11.
6. Remove the block and place it between the middle-rear of the head casting and the table. If there is a gap or it will not fit under the head casting, measure the difference with a feeler gauge. If this measurement is more than .002", then the table needs to be adjusted from front to back.
7. There are two methods to adjust the table on the Model W1683. The first is for adjustments smaller than .016" and the second is for adjustments larger than .016".

To adjust the table less than .016":

1. Use the table mounting screws shown in Figure 12. Loosen the screws and lift/lower the table until the table and the cutterhead body are parallel with each other and the table is parallel with the head casting from front to back. This may require some trial and error.
2. Adjust each column on both sides until the table is properly set. While adjusting the columns, tighten each screw after each step to ensure accurate results.

To adjust the table more than .016":

1. Remove the front cabinet cover.
2. On the underside of the table there is a chain drive and five sprockets as shown in **Figure 13**. The four sprockets in the corners control the movement of the table columns. The fifth sprocket is the idler sprocket that controls the chain tension. Loosen the two bolts on the idler sprocket bracket (as shown in **Figure 13**) to loosen the chain so that each sprocket can be rotated on its own. Make sure to hold the chain away from the sprocket while you adjust it.
3. Moving the sprockets clockwise lowers the table and moving them counter-clockwise raises the table. Each tooth on the corner sprockets equals .016" of vertical movement when the cogs are turned (see illustration in **Figure 14**). Make sure, as you adjust each sprocket, that you count the number of teeth that pass a fixed point.

Knowing how far you turned one sprocket will help you keep the other side consistent if you are adjusting two columns together.

4. After you have the table adjusted to within .016" from front-to-back and from side-to-side, tighten the chain so all of the slack is removed.
5. Now follow the previous instructions for adjusting the table when it is less than .016" from its proper position.

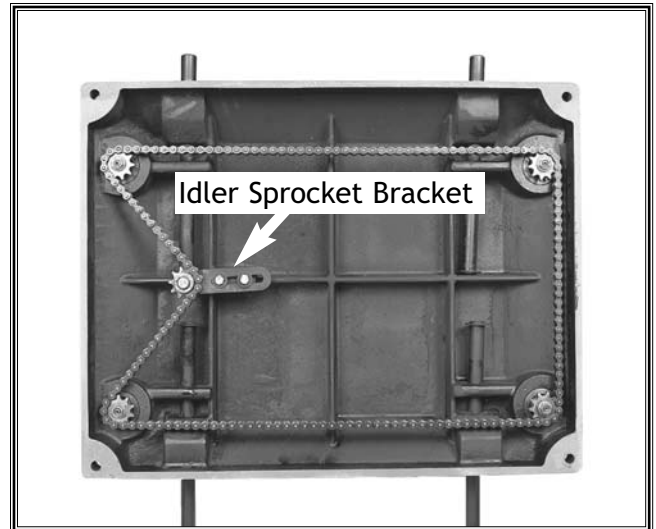


Figure 13. Underside of table.

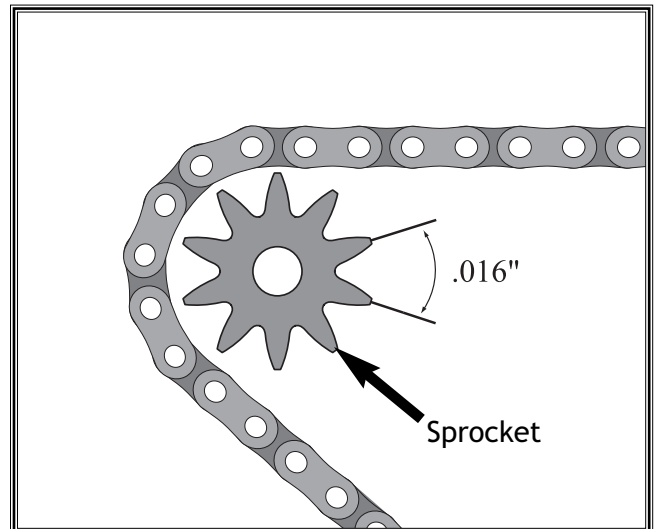


Figure 14. Understanding sprocket movement.

	<p>⚠ WARNING Do not connect power to the machine while performing adjustments. Failure to follow this warning may result in serious personal injury.</p>
--	--



Figure 15. Cover removed from planer.

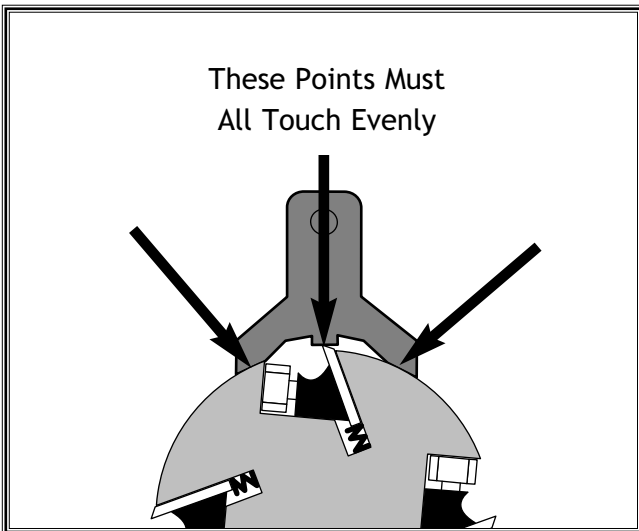


Figure 16. Correct jig position on cutterhead.

Checking Knives

The Model W1683 features a 4 knife cutterhead. These knives must be checked and adjusted after regular use. Adjusting the knives is also an important part of the maintenance process. Correctly positioned knives act as a reference point for adjusting the feed rollers, the chip breaker and the pressure bar.

When checking/adjusting the knives, keep in mind that the knife edge should be as precise as possible at tolerances within .002" from one end to the other. Improperly adjusted knives may unbalance the cutterhead, reduce the sharpness of knife edges prematurely, shorten bearing life, and produce poor planing results.

To check the knives:

1. Remove the upper cover as shown in Figure 15 so you have access to the top of the cutterhead.
2. Remove the V-belt cover from the left-hand side of the planer (facing front).
3. Using the V-belt to rotate the cutterhead, turn the cutterhead so one of the knives is accessible.
4. Place the knife setting jig on the cutterhead. Both feet should sit solidly on the cutterhead and the knife should barely touch the center of the jig as shown in Figure 16.
5. If the knife does not contact the center of the jig, or if the knife contacts the center of the jig but both feet will not sit solidly on the cutterhead, then the knives will need to be adjusted.

For quick and easy knife setup, consider purchasing a Planer Pal®. This handy tool allows you to quickly set the knives to within .001" from one end to the other. See "Aftermarket Accessories" at the end of the *Operations* section for more details.

Knife Adjustment

The Model W1683 is equipped with both springs and jack screws for knife adjustment. These two options have been provided for operator preference. Both types have advantages and disadvantages. Springs allow adjustments to be made quickly, while jack screws are more accurate. The following instructions offer suggestions for both methods, followed by the procedures for tightening the gib bolts.

Springs under the knives exert upward pressure while wedge-type gibs and gib bolts lock the knives in place. See **Figure 17** for cutterhead assembly identification.

To adjust the knives using the springs:

1. Unplug the machine from the power source!
2. Lower the jack screws completely to get them out of the way. Loosen the gib bolts so the knife will move upward from the pressure of the springs.
3. Place the knife setting jig on the cutterhead so both feet sit solidly on the cutterhead and so that the center of the jig pushes down on the knife (similar to **Figure 16**). Make sure equal pressure is placed on both ends of the jig and that the jig is parallel with the cutterhead.
4. Tighten the knives by following "tightening" instructions on the next page.

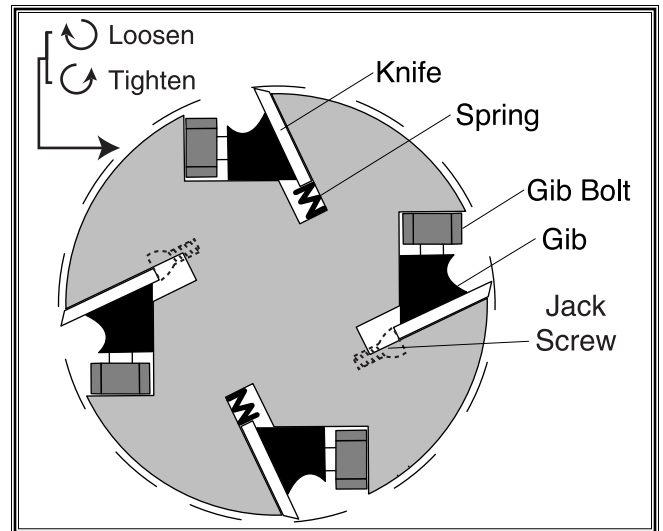


Figure 17. Understanding cutterhead assembly.

Jack Screws support the knives from underneath. By threading the jack screws in or out, you can precisely control the knife height.

To adjust the knives using the jack screws:

1. Unplug the machine from the power source!
2. Loosen the gib bolts and remove the gib and knives. Remove all of the springs and place them in a plastic bag. Tape the bag to the inside of the cabinet so they do not get lost.
3. Place the knives, gibs, and gib bolts back in the cutterhead as they were before removal. Make sure the knives are resting on the jack screws when you install them.
4. Place the knife setting jig on the cutterhead so both feet sit solidly on the body of the cutterhead. If the knife does not allow the jig to sit on the cutterhead evenly, raise or lower the knife with the jack screws to adjust as needed.
5. Tighten the knives by following the "tightening" instructions on the next page.

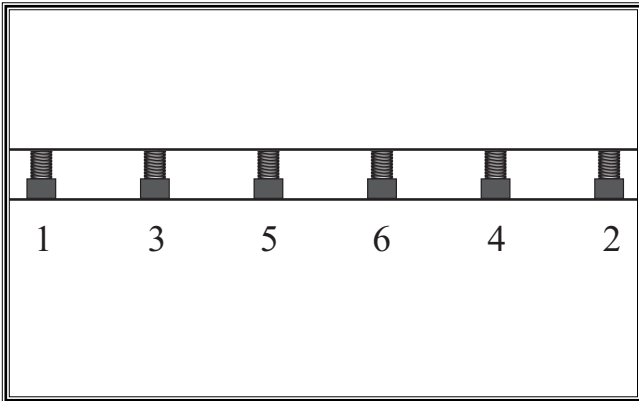
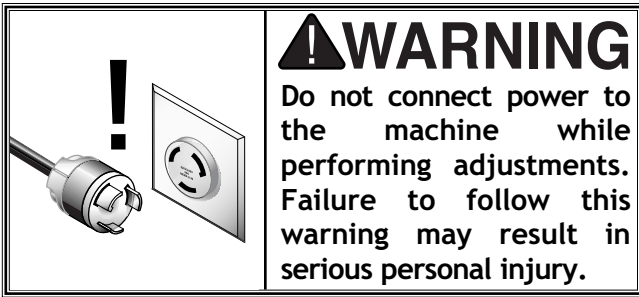
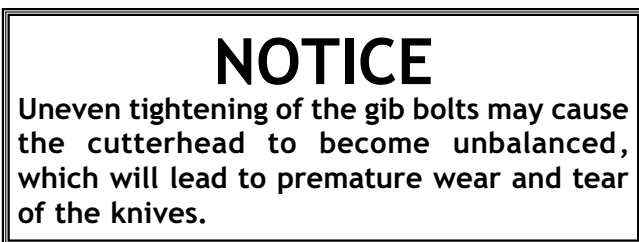
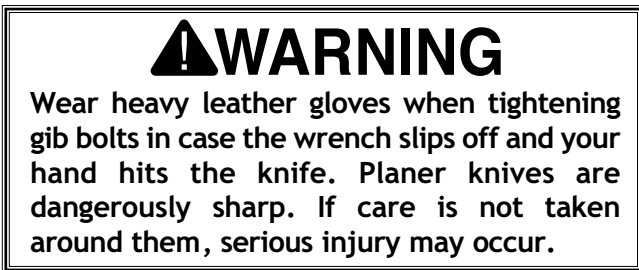


Figure 18. Gib bolt tightening sequence.



To tighten the knives after adjustment:

1. Snug the gib bolts on each end of the knife but do not completely tighten them. In this manner, work toward the center of the knife by alternating back-and-forth from each end of the knife. **Figure 18** illustrates order of this sequence. Make sure you only snug the gib bolts enough to hold the knife in place. You will tighten them more later.
2. Rotate the cutterhead and repeat knife adjustments and **step 1** tightening until you have performed these procedures on all of the knives.
3. When you come back to the knife you started with, check the height with the jig to make sure that it is still correct. If the bolt height is not correct, fix as necessary and re-snug the gib bolts; if the height is correct, snug each bolt down a little more in the same alternating procedure you used before, but do not tighten the bolts completely. Repeat again with each knife.
4. When you return to the original knife, tighten all gibs **completely** in the same fashion, repeating on all knives.

Feed Rollers, Chip Breaker & Pressure Bar

The feed rollers, the chip breaker and the pressure bar are factory set for general planing. If you need to alter the settings or reset them after maintenance, these components can be adjusted at the same time, assuming that the knife height is set correctly. The standard setting for the infeed roller, the chipbreaker and the pressure bar is .004"-.008" below the cutterhead knife at bottom dead center. The outfeed roller should be set to .020" below the cutterhead knife at bottom dead center.

To adjust the feed rollers, the chip breaker and the pressure bar:

1. **Unplug the machine from the power source!**
2. You will need two boards that are the same height and are long enough to span the entire length of the table. An easy way to get two boards of the same height is to rip one board down the middle.
3. Place each board across the entire length of the table, on each side of the table, similar to **Figure 19**.
4. Rotate the cutterhead with the V-belt pulley so one of the knives is at bottom dead center. Bottom dead center is the furthest point down that the knife reaches in its rotation. The black line underneath the cutterhead in **Figure 20** represents bottom dead center.
5. Raise the table up until the boards barely touch the knife edge.
6. Lower the feed rollers onto the boards with the adjustment controls shown in **Figure 21**.



Figure 19. Board position on table.

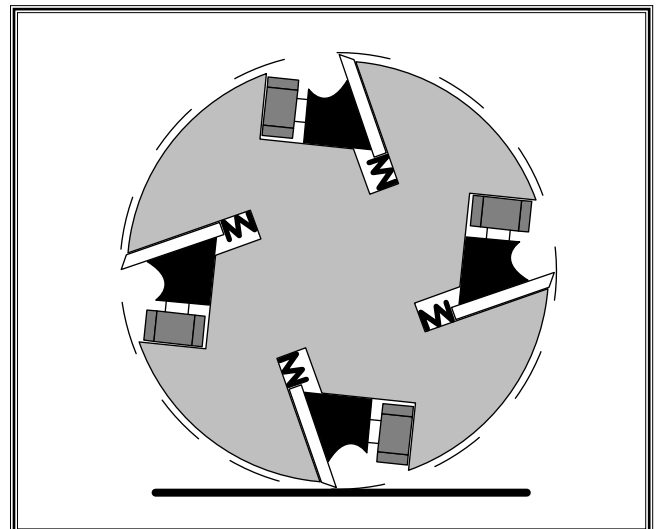


Figure 20. Bottom dead center.

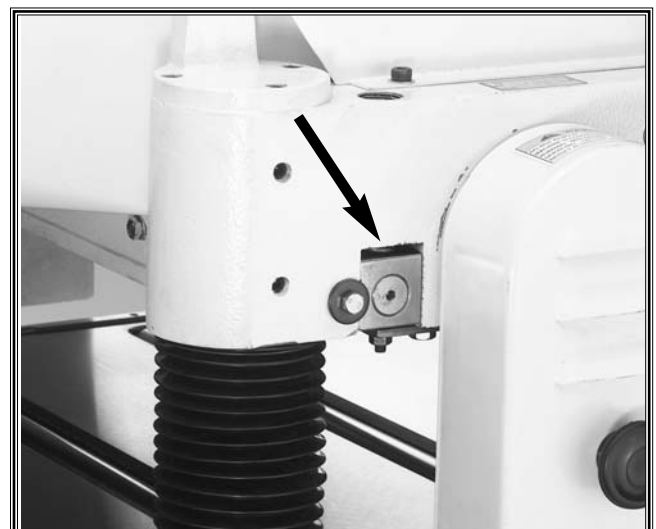


Figure 21. Feed roller adjustment controls.

ADJUSTMENTS



Figure 22. Chipbreaker adjustment controls.

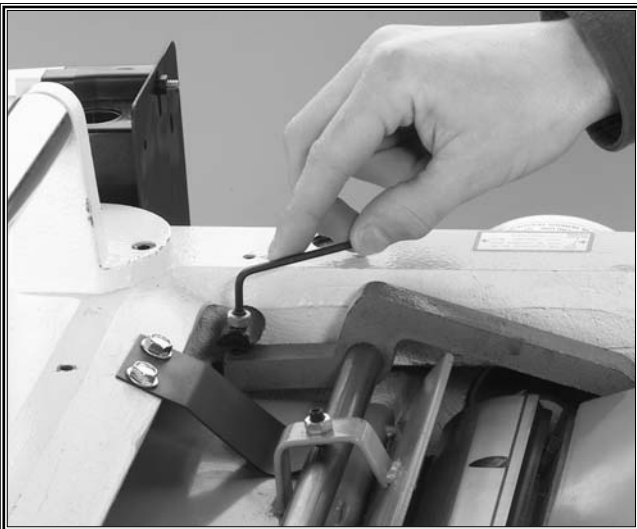


Figure 23. Pressure bar adjustment controls.

7. Lower the chipbreaker and the pressure bar onto the boards, using the adjustment controls shown in **Figures 22 and 23**.
8. Make sure that each of the adjustment controls for the feed rollers, the chipbreaker and the pressure bar are backed off enough so that they will allow the components to move below the current position on the board.
9. To accurately perform this adjustment, you will need a dial indicator (not included). Place the dial indicator near the Shop Fox name plate that is directly above the table.
10. Position the indicator plunger on the table and lower the table .004"-.008". The feed rollers, the chipbreaker and the pressure bar should all move freely with the table. If they do not, make sure that they are all resting evenly on the boards at this current position.
11. Lock the infeed roller, the chipbreaker and the pressure bar in place. They should now all be set between .004"-.008" below the knife edge when it is at bottom dead center.
12. The outfeed roller should still be able to move with the table. Continue lowering the table another .012" (.008" + .012" = .020"). The outfeed roller should now be set to approximately .020" below the knife edge at bottom dead center. Lock the outfeed roller in place.

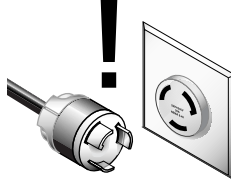
For super accurate setup, consider purchasing a Rotacator®. This handy tool allows you to adjust the feed rollers, chipbreaker, and pressure bar to accuracy within .001" every time. See "Aftermarket Accessories" at the end of the *Operations* section for more details.

Chip Deflector

A chip deflector is mounted behind the cutterhead to keep wood chips from falling onto the outfeed roller.

To adjust the chip deflector:

1. Loosen the chip deflector mounting bolts shown in **Figure 24**.
2. Make sure the deflector is angled toward the cutterhead. Position the edge of the deflector to approximately $\frac{1}{16}$ " from the knife edge. Rotate the cutterhead with the V-belt pulley and make sure there is enough clearance between all the knives and the chip deflector.
3. Re-tighten the mounting bolts and replace the top cover.



! WARNING
The power should not be connected to the planer at this time! If it is, serious injury may occur.

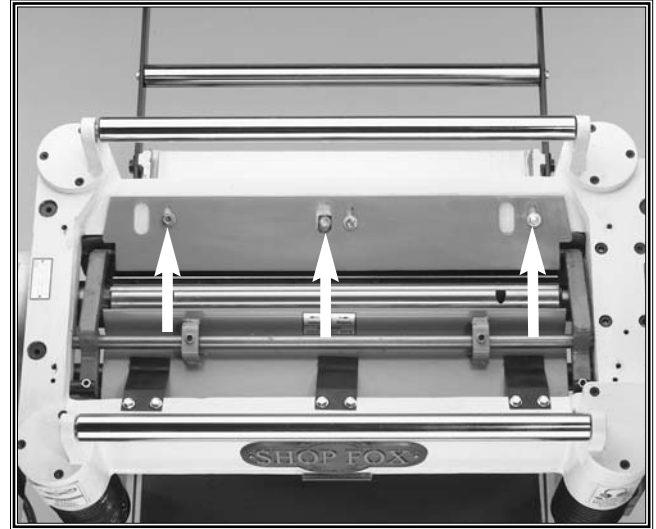


Figure 24. Chip deflector mounting bolts.

NOTICE

If you use a dust collector, move the chip deflector slightly farther away from the knives to help remove chips better.



Figure 25. Anti-kickback pawls.

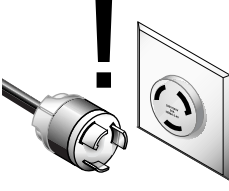
Anti-Kickback Pawls

The Model W1683 features anti-kickback pawls (shown in **Figure 25**) as an important safety feature. These safety devices allow the workpiece to enter the planer without affecting the proper operation, but are designed to stop the workpiece from coming back out of the entrance in the event of a kickback.

The anti-kickback pawls should be frequently checked to ensure that they swing free and easy. Do not try to lubricate the pawls. Lubrication may cause dust to build-up, which will restrict movement.

! CAUTION
Proper operation of the anti-kickback pawls is essential to the safe operation of the planer. If they aren't working properly, they will not protect you if a kickback occurs.

ADJUSTMENTS



⚠ WARNING
The power should not be connected to the planer at this time! If it is, serious injury may occur.

Chain Tensioner

After setting the feed rollers, the chipbreaker and the pressure bar, the chain tensioner (shown in **Figure 26**) must be reset for the planer to operate properly. Incorrect chain tension may cause the feed rollers to jam or even cause the chain to break.

To adjust the chain tensioner:

1. Remove the chain drive cover and the backing plate.
2. Place the block of wood described on **page 14** under the right side of only the outfeed roller. Raise the table up so the block barely touches the outfeed roller.
3. Look at the current table height on the scale. Raise the table up 1mm, using the scale as a gauge. This will move the outfeed roller up approximately .040".
4. Loosen tensioner bracket screw, rotate the chain tensioner until the chain is tight, then secure the tensioner bracket screw to keep the tensioner in place.
5. Replace the backing plate and the chain drive cover.

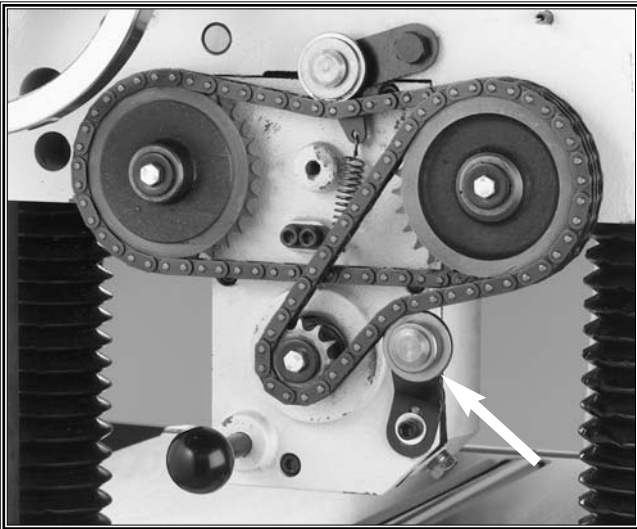


Figure 26. Chain tensioner.



Figure 27. Roller spring tension adjustment screws.

NOTICE

More adjustments may be necessary to the roller spring tension after the machine has been test run and is in safe working condition. See the *Operations* section for more details.

Spring Tension

Roller spring tension keeps the roller pressure uniform as the workpiece moves through the planer. To adjust the roller spring tension:

1. **Figure 27** shows the four spring adjustment screws. Adjust screws **A**, **B** & **C** so they protrude $\frac{1}{8}$ " above the head casting.
2. Adjust screw **D** so it protrudes $\frac{5}{16}$ " above the head casting. This extra height will compensate for the pressure of the chain during operation.

Table Rollers

The table rollers should be set last so they stay out of the way during the other adjustments. The required height of the table rollers will vary depending on the type of stock you intend to plane.

As a general rule, table roller height should be between .002" and .020" above the table (see **Figure 28**). However, some stock may have better results outside of these numbers. Often, a small amount of trial-and-error is required to find the best table roller height for any particular stock. Rough stock will plane better when the rollers are higher, and smooth stock will have less snipe when the rollers are lower.

To adjust the table roller height:

1. Place a good straightedge across the length of the table as shown in **Figure 29**.
2. Use a feeler gauge to measure the gap between the table surface and the straightedge, and adjust the table rollers as described on **page 14** to reach the desired height. The gap between the straightedge and the table should be even all the way across the table.

For quick and easy table roller setup, consider purchasing a Rotacator®. This handy tool allows you to watch the height of the table roller as you adjust it, giving you accuracy within .001" every time. See "Aftermarket Accessories" at the end of the *Operations* section for more details.

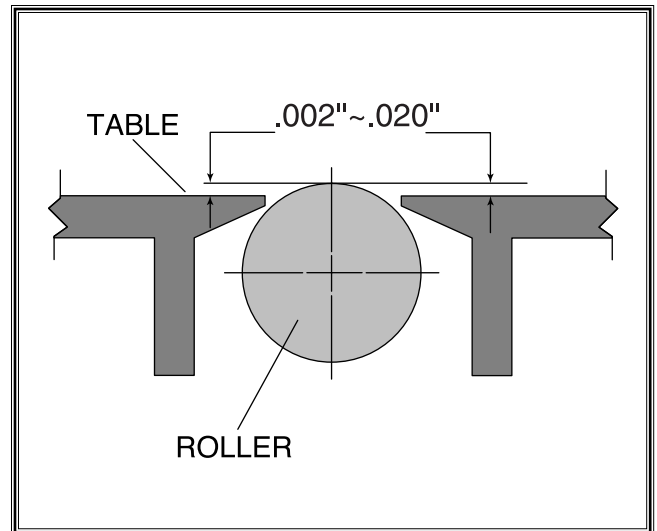


Figure 28. Table roller tolerances.

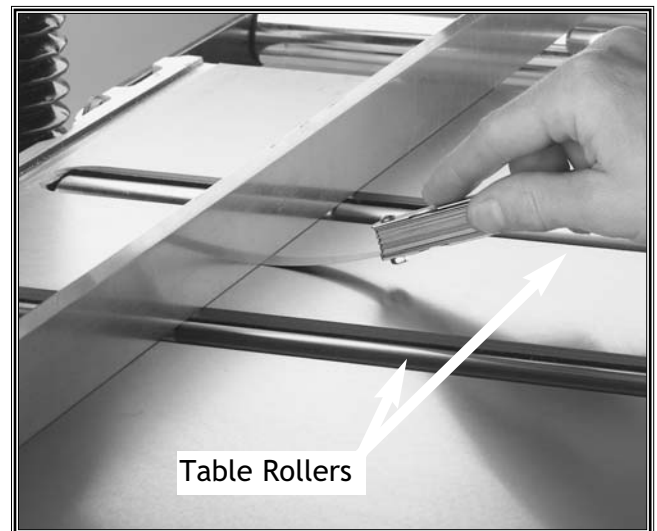


Figure 29. Measuring gap between straightedge and table with a feeler gauge.

Operations

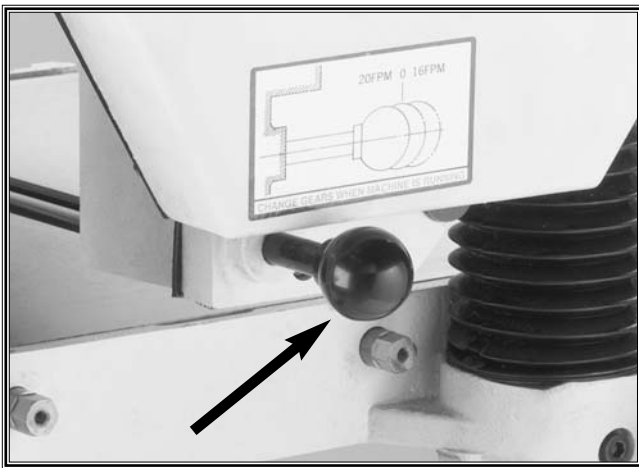
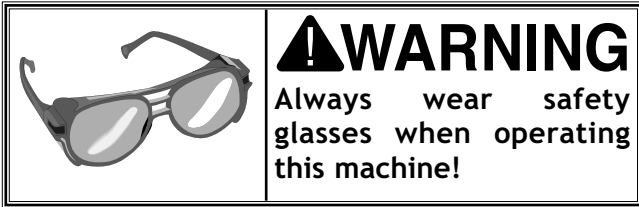


Figure 30. Feed rate knob.

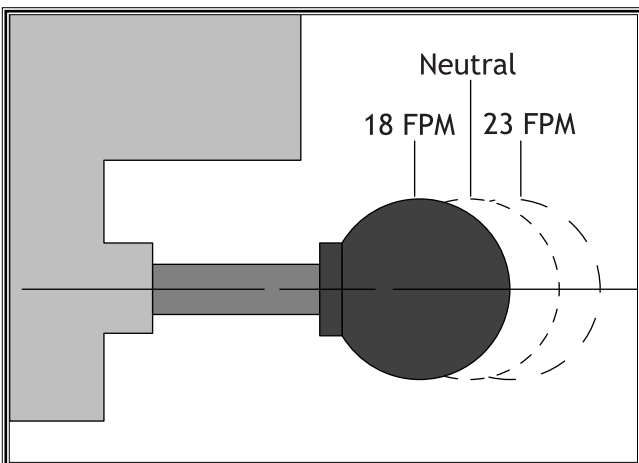
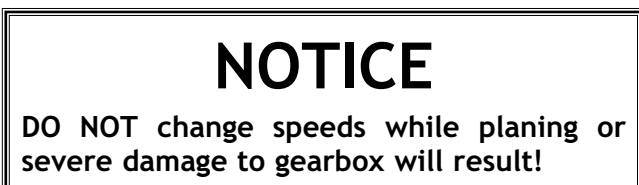


Figure 31. Feed rate knob positions.



Test Run

Before turning the machine on for the first time, make sure you have read through the entire manual and have performed the instructions given in the *Assembly* and *Adjustments* sections.

Once assembly and adjustments have been properly performed, the machine is ready to be connected to the power. Make sure there are no obvious safety hazards and any tools used to assemble/adjust the machine are properly cleared away. The table should be lowered enough to provide plenty of room for the safe operation of the feed rollers and the cutterhead.

Press the *START* button. Make sure that you remain near the switch in case you have to press the *STOP* button in an emergency. Strange or unnatural noises should be investigated and corrected before operating the machine further.

Feed Rate

The feed rate is the speed that the rollers drive the workpiece through the planer. The Model W1683 features 18 and 23 F.P.M. feed rates.

As a general rule, the faster feed rate will dimension lumber quicker but leave a rougher finish; the slower feed rate will have the opposite effect and leave a smoother finish. Often, a small amount of trial-and-error will be the best way to determine which setting is right for your particular application.

To change the feed roller speed, locate the feed rate knob shown in **Figure 30**. The machine must be running in order to change speeds; however, you should NEVER be planing stock through the machine when you switch speeds. Start the planer and adjust the knob as illustrated in **Figure 31**.

Operational Tips

- Carefully inspect any lumber that you plan to run through the planer. Each board must have at least one flat surface to slide along the planer table. To create a flat surface, pass the stock over a jointer first. See **Figure 32**. Some defects such as moderate twisting, loose knots or severe cracks may make the stock unusable.
- Only use clean stock. See **Figure 33**. Scrape off all glue from joined boards before planing. Remove all dirt, nails, staples, imbedded gravel, etc. from any lumber you plan on using. A hidden nail in a workpiece will instantly damage the sharp edges of the knives. This will cause unsatisfactory results in future operations.
- Plane ONLY natural wood fiber. Never plane wood composites such as particle board, plywood or MDF. Never plane laminates, formica or other synthetic materials.
- Surface wood in the same direction as the grain. Never feed end-cut or end-grained lumber into the planer.
- Keep your work area clear. Always make sure that long workpieces are supported and have enough room to exit the planer.
- When making multiple passes with long stock, use the top rollers to move material back to the infeed side of the planer.
- Avoid planing wood with a high moisture content. Stock with more than 20% moisture, or stock that has been exposed to rain or snow, will plane poorly and cause unnecessary wear on the knives and motor. Excess moisture may also cause rust or corrosion problems.

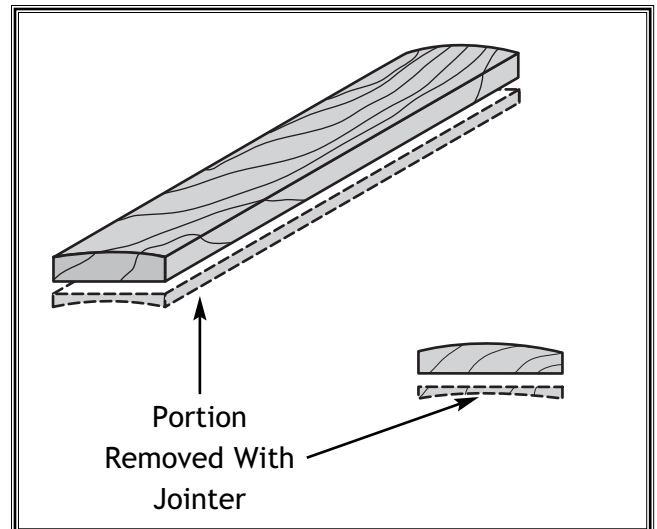


Figure 32. Face joint the concave side of cupped stock before planing.

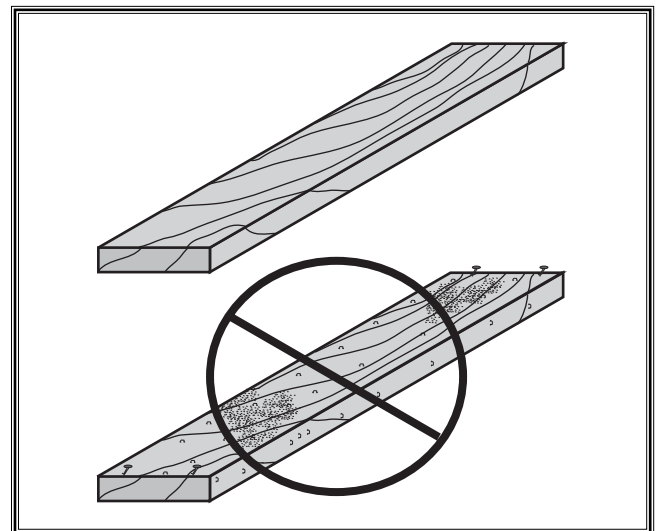


Figure 33. Only plane clean stock.

Troubleshooting Planing Results

Planing results are affected by the species and condition of the wood, how the planer is setup, and the condition of the knives. The following characteristics are common problems woodworkers might have while planing.

Snipe – Where more material is removed from board ends than the middle of the board. This condition occurs with all planers to some degree. Usually exaggerated when one or both bed rollers are set too high, this condition can also be caused by the chipbreaker or the pressure bar being set too high. Adjustment of the above components should reduce snipe beyond notice.

Chatter Marks – Usually caused by incorrect chipbreaker and pressure bar settings. Can also be caused by running a narrow workpiece through the planer on the far left or right side of the cutterhead. Shows up in the form of a “washboard” look across the face of the freshly planed workpiece. Likely to be inconsistent in appearance.

Chip Marks – Occur when chips are not properly expelled from the cutterhead. The chips get caught between the knives and the workpiece, hindering the ability of the knife to take an even cut. Chip marks usually appear as random and uneven. They can also be caused by exhaust blockage or too large of a gap between the chip deflector and the cutterhead. Using a dust collector with the planer will help this situation.

Wavy Surface – Usually caused by poor knife height adjustment. Appears when one knife is taking deeper cuts than the others. Can be fixed by resetting the knives to a tolerance within .001” from one end to the other.

Note that one knife being slightly higher than the others will also result in that knife dulling at a faster rate, because it is doing more work.

Chipped Grain – Frequently a result of planing against the grain. May also be caused by wood with knots or cross grain, dull knives or a misaligned chipbreaker. Chipped Grain can usually be avoided by slowing down the feed rate and by taking more shallow cuts. Inspect your lumber and determine if grain is causing the problem.

Fuzzy Grain – Commonly caused by surfacing lumber with too high of a moisture content. Fuzzy grain can also be caused by dull knives or an incorrect grinding bevel on the knives. Check stock with a moisture meter. Anything over 20% should be stickered and allowed to dry.

Glossy Surface – Most often caused by dull knives taking shallow cuts at a slow feed speed. The lumber usually gets scorched and blackens the surface of the stock; eventually damage to the knives will occur. If knives are sharp and a glossy surface still results, increase the feed speed or cutting depth.

Pitch & Glue Build-Up – Resin or glue build-up on the rollers and the cutterhead will cause over-heating by decreasing the cutting sharpness while increasing drag in the feed mechanism. Scorched lumber, as well as uneven knife marks and chatter, can result.

AFTERMARKET SETUP ACCESSORIES

To make the setup process easier and more accurate, consider some of the aftermarket products available.

Here are some basic aftermarket items you might want to consider:

- **Rotacator®** – A rotating dial indicator on a magnetic base. Shown in **Figures 34 and 35**, this handy device allows you to set your table within .001" from being parallel with the cutterhead. The Rotacator® is indispensable for adjusting the table rollers and is also great for precisely setting feed rollers, the chip breaker and the pressure bar.
- **Planer Pal®** – Using powerful neodymium magnets, Planer Pal® (**Figure 36**) hold knives in place while freeing both hands to tighten the gib. Place one of these jigs on each end of the cutterhead, and you can set the knives in perfect alignment every time.



Figure 34. Measuring table-to-cutterhead with Rotacator® in upward position.

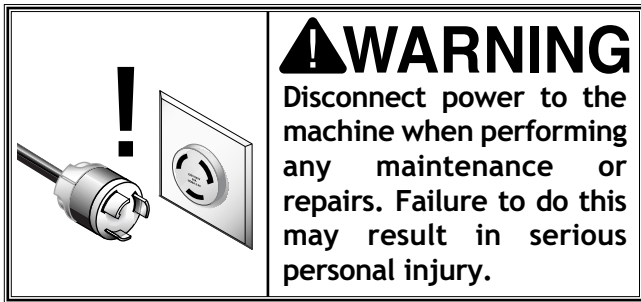


Figure 35. Measuring table roller height with Rotacator® in downward position.



Figure 36. Planer Pal® knife setting jig.

MAINTENANCE



General

Regular periodic maintenance on your Model W1683 20" Planer will ensure its optimum performance. Make a habit of inspecting your planer each time you use it.

Check for the following conditions and repair or replace when necessary:

- Loose mounting bolts.
- Worn switch.
- Worn or damaged cords and plugs.
- Damaged V-belt.
- Any other condition that could hamper the safe operation of this machine.

Cleaning

Frequently blow-off dust with compressed air. This is especially important for the internal working parts and motor. Dust build-up around the motor is a sure way to decrease its life span.

Occasionally it will become necessary to clean the internal parts with more than compressed air. To do this, remove the covers and clean the internal parts with a citrus cleaner or mineral spirits and a stiff wire brush or steel wool. **DO NOT USE WATER—WATER WILL RUST CAST IRON.** Make sure the internal workings are dry before using the planer again. If any essential lubrication is removed during cleaning, relubricate those areas.

Table And Base

The table can be kept rust-free with regular applications of products like Boeshield® T-9. For long term storage, you may want to consider products like Kleen Bore's Rust Guardit™.

Lubrication

Since all bearings are sealed and permanently lubricated, leave them alone until they need to be replaced. Do not lubricate them.

The Model W1683 does need lubrication in other places.

- **Columns and Lead Screws** – Remove dust covers for access. Lubricate columns weekly with light oil, and lubricate the four lead screws once a month with general purpose grease.
- **Worm Gear** – Inspect the worm gear monthly and lubricate when needed. The worm gear box will need to be removed to perform the inspection. See **Figure 37**.
- **Chain** – Inspect the table height adjustment chain monthly and lubricate as needed. Use high quality chain lubricant for best results.
- **Gear Box** – Drain the gear box after the first 20 hours of operation. **Figure 38** shows the gear box drain and fill plugs. Refill with 80-90w gear oil. The oil level should reach the top of the filler plug port. After the initial change, inspect fluid levels periodically and change yearly. *If your planer receives heavy use, change the gear oil more frequently.*
- **Drive Chain** – Inspect and lubricate the drive chain monthly. Check the sprockets, the chain, and the master links during inspection. Use a general purpose grease to lubricate the chain.
- **Feed Rollers** – Lubricate feed rollers daily before start-up. **Figure 39** shows the lubrication points for the feed rollers. These are screws that have holes drilled through them to allow oiling. Make sure that dust is not trapped in these screws and apply 2 drops of light oil in each to penetrate the bearings. Do not lubricate more than this or the excess will end up on the floor.



Figure 37. Worm gear.

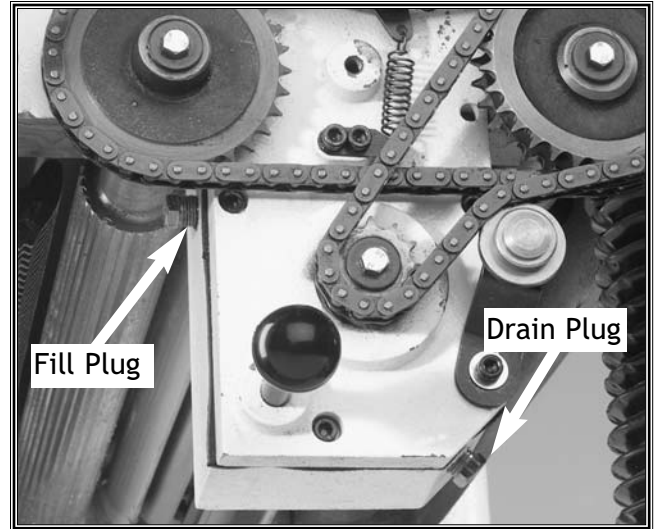


Figure 38. Gear box drain and fill plugs.



Figure 39. Bearing lubrication points.



Figure 40. V-belt adjustment check nuts.

Belt Tension

Frequently inspect the V-belt tension during the first twenty hours of operation. During this period, the belts will stretch a little.

To adjust belt tension, lower the motor slightly by loosening the lower check nuts shown in **Figure 40**. When belt tension is satisfactory, tighten the upper check nuts down onto the motor bracket to secure it.

DO NOT over-tighten the check nuts—too much pressure at the wrong angle may break the motor mount casting ears.

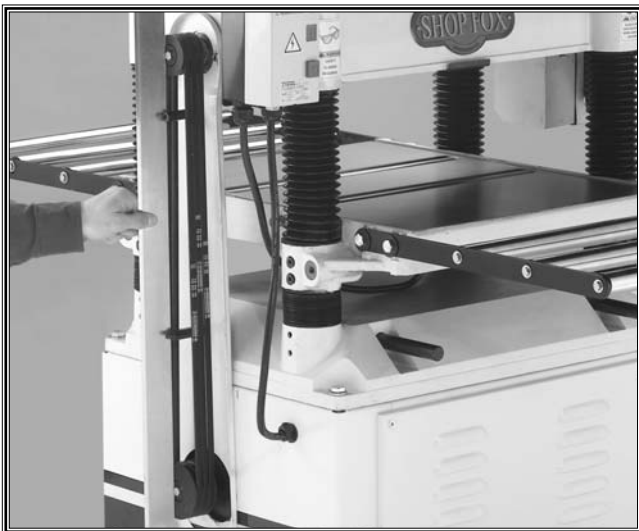


Figure 41. Aligning V-belt pulleys.

Pulley Alignment

The V-belt pulleys should be properly aligned with each other to prevent premature belt wear. Check the alignment with a good quality straightedge as shown in **Figure 41**.

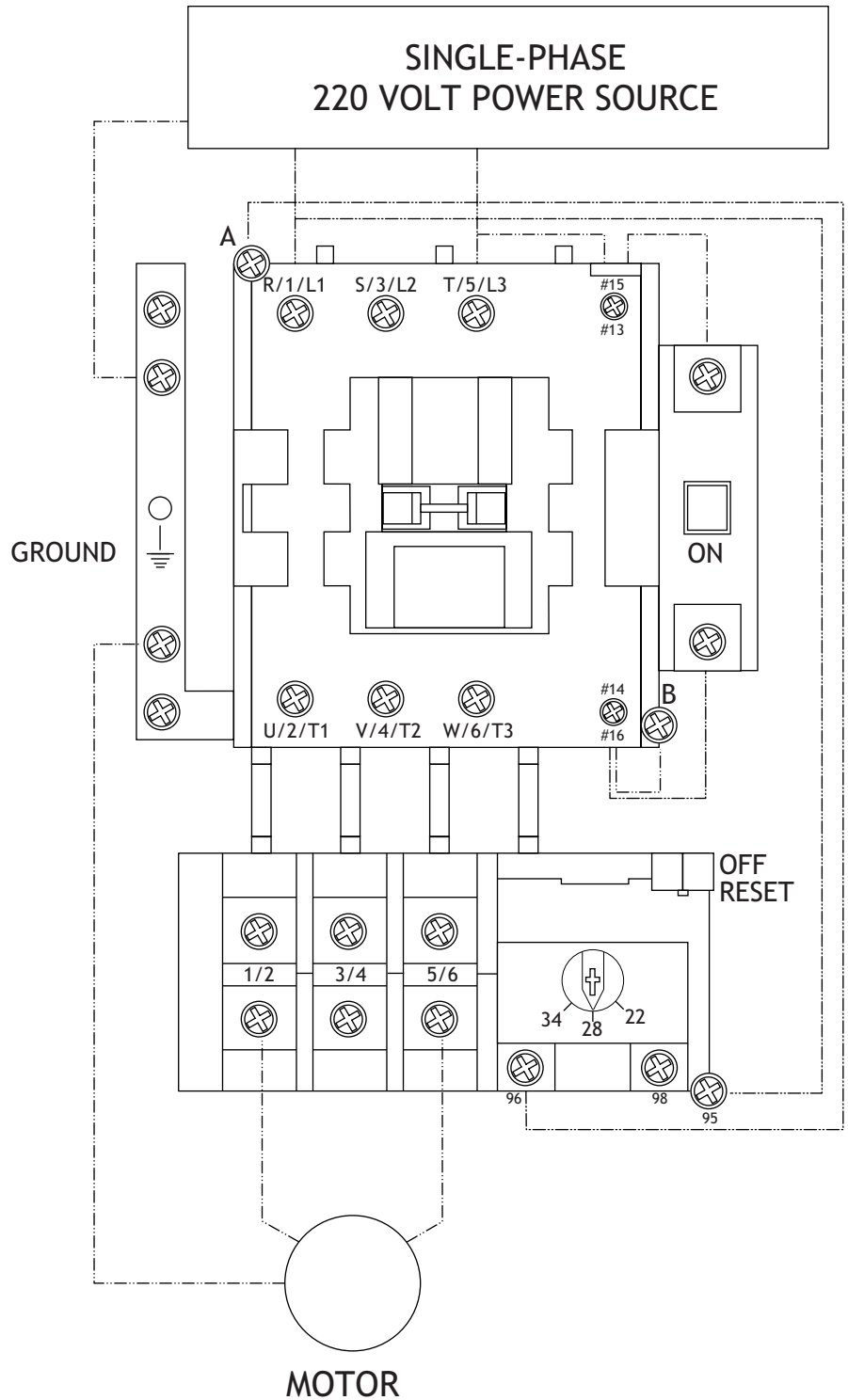
To align the pulleys:

1. Loosen the belt tension check nuts so the motor will freely move up and down.
2. Loosen, but do not remove, the 4 bolts that secure the motor to the motor mounting plate.
3. Slide the motor as needed to align the pulleys.
4. When the pulleys are aligned, tighten the 4 motor mount bolts.
5. Tension the V-belts and replace the belt cover.

Wiring Diagram

5 HP Magnetic Switch -L.Z. Type

⚠ DANGER
 Disconnect power from machine before performing any electrical service. Failure to do this will result in a shock hazard leading to injury



MAINTENANCE

TROUBLESHOOTING

This section covers the most common processing problems encountered in planing and what to do about them. Do not make any adjustments until planer is unplugged and moving parts have come to a complete stop.

SYMPTOM	POSSIBLE CAUSE	CORRECTIVE ACTION
Motor will not start.	<ol style="list-style-type: none"> 1. Low voltage. 2. Open circuit in motor or loose connections. 	<ol style="list-style-type: none"> 1. Check power line for proper voltage. 2. Inspect all lead connections on motor for loose or open connections.
Motor will not start; fuses or circuit breakers blow.	<ol style="list-style-type: none"> 1. Short circuit in line cord or plug. 2. Short circuit in motor or loose connections. 3. Incorrect fuses or circuit breakers in power line. 	<ol style="list-style-type: none"> 1. Inspect cord or plug for damaged insulation and shorted wires. 2. Inspect all connections on motor for loose or shorted terminals or worn insulation. 3. Install correct fuses or circuit breakers.
Motor overheats.	<ol style="list-style-type: none"> 1. Motor overloaded. 2. Air circulation through the motor restricted. 	<ol style="list-style-type: none"> 1. Reduce load on motor. 2. Clean out motor to provide normal air circulation.
Motor stalls (resulting in blown fuses or tripped circuit).	<ol style="list-style-type: none"> 1. Short circuit in motor or loose connections. 2. Low voltage. 3. Incorrect fuses or circuit breakers in power line. 4. Motor overloaded. 	<ol style="list-style-type: none"> 1. Inspect connections on motor for loose or shorted terminals or worn insulation. 2. Correct the low voltage conditions. 3. Install correct fuses or circuit breakers. 4. Reduce load on motor.
Machine slows when operating.	<ol style="list-style-type: none"> 1. Feed rate too high. 2. Depth of cut too great. 	<ol style="list-style-type: none"> 1. Feed workpiece slower. 2. Reduce depth of cut.
Loud, repetitious noise coming from machine	<ol style="list-style-type: none"> 1. Pulley setscrews or keys are missing or loose. 2. Motor fan is hitting the cover. 3. V-belt is defective 	<ol style="list-style-type: none"> 1. Inspect keys and setscrews. Replace or tighten if necessary. 2. Tighten fan or shim cover. 3. Replace V-belt. See Maintenance.
Machine is loud when cutting. Overheats or bogs down in the cut.	<ol style="list-style-type: none"> 1. Excessive depth of cut. 2. Knives are dull 	<ol style="list-style-type: none"> 1. Decrease depth of cut. 2. Sharpen knives.
Infeed roller marks are left on the workpiece.	<ol style="list-style-type: none"> 1. Depth of cut too shallow. 	<ol style="list-style-type: none"> 1. Increase depth of cut.
Outfeed roller marks are left on right side of workpiece.	<ol style="list-style-type: none"> 1. Too much spring tension on feed roller. 	<ol style="list-style-type: none"> 1. Refer to Adjustments, Spring Tension.
Cannot control snipe.	<ol style="list-style-type: none"> 1. Long or heavy board sags as it enters and exits. 	<ol style="list-style-type: none"> 1. Lift up on unsupported end of board as it enters and exits cutterhead.
Chip buildup on outfeed roller.	<ol style="list-style-type: none"> 1. Chips working their way back under the chip deflector. 	<ol style="list-style-type: none"> 1. Lay duct tape over the mounting bolts along the outside edge to seal any possible gaps.
Machine howls on startup.	<ol style="list-style-type: none"> 1. Chip deflector too close to the cutterhead. 	<ol style="list-style-type: none"> 1. Move back 1/8" to 1/4" from the cutterhead.
Table moves down while cutting.	<ol style="list-style-type: none"> 1. Knives dull 	<ol style="list-style-type: none"> 1. Replace knives.

CLOSURE

The following pages contain general machine data, parts diagrams/lists and warranty/return information for your Shop Fox® Model W1683 20" Planer.

If you need parts or help in assembling your machine, or if you need operational information, we encourage you to call our Service Department. Our trained service technicians will be glad to help you.

If you have comments dealing specifically with this manual, please write to us using the address in *General Information* part of this manual. The specifications, drawings and photographs illustrated in this manual represent the Model W1683 as supplied when the manual was prepared. However, due to Woodstock International, Inc.'s policy of continuous improvement, changes may be made at any time with no obligation on the part of Woodstock International, Inc. Whenever possible, though, we send manual updates to all owners of a particular tool or machine. Should you receive one, add the new information to this manual and keep it for reference.

We have included some important safety measures that are essential to the operation of this machine. While most safety measures are generally universal, we remind you that each workshop is different and safety rules should be considered as they apply to your specific situation.

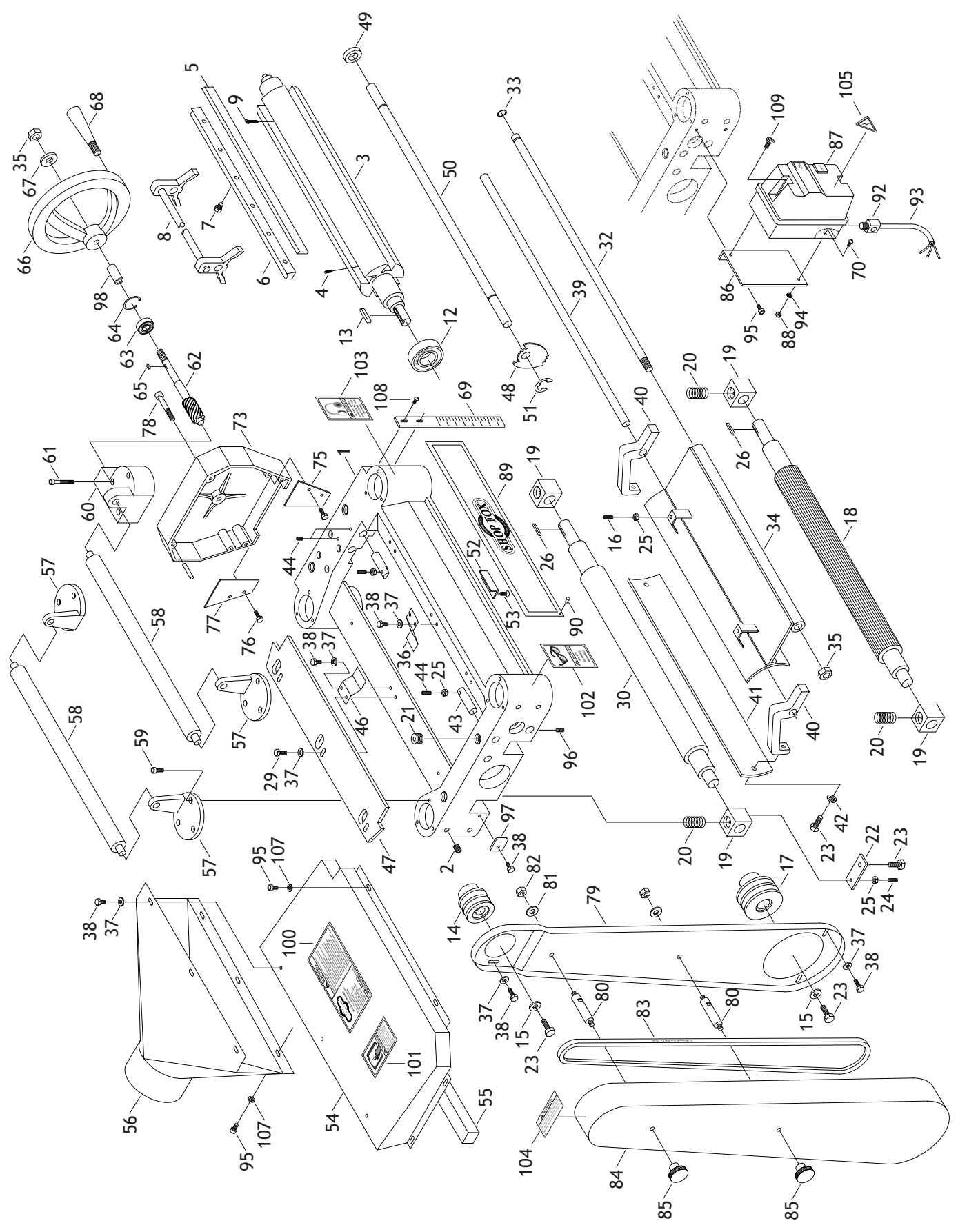
We recommend you keep this manual for complete information regarding Woodstock International, Inc.'s warranty and return policy. If you need additional technical information relating to this machine, or if you need general assistance or replacement parts, please contact the Service Department at 1-360-734-3482 or tech-support@woodstockint.com.

Additional information sources are necessary to realize the full potential of this machine. Trade journals, woodworking magazines and your local library are good places to start.

WARNING

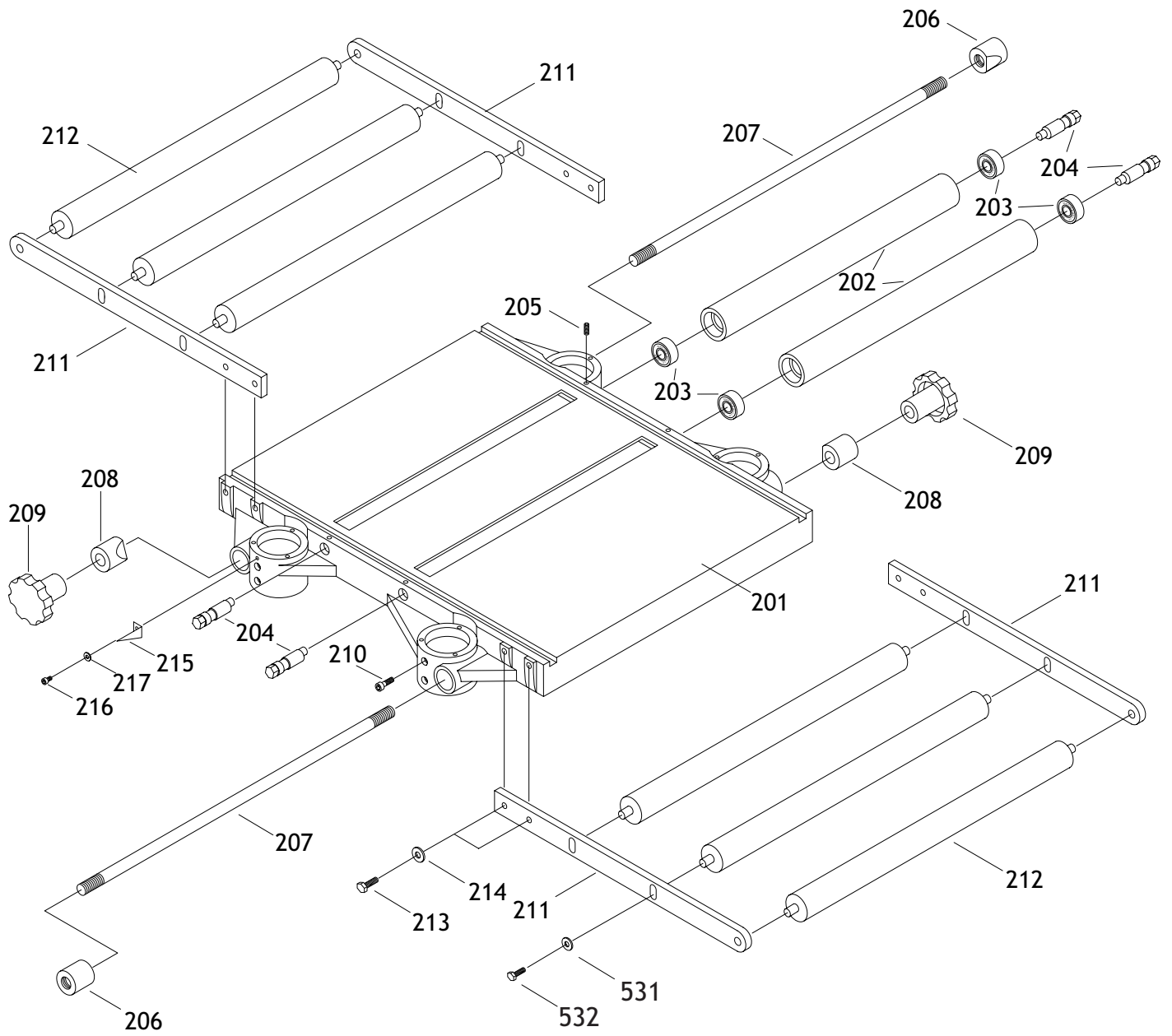
As with all power tools, there is danger associated with the Model W1683. Use the tool with respect and caution to lessen the possibility of mechanical damage or operator injury. If normal safety precautions are overlooked or ignored, injury to the operator or others is likely.

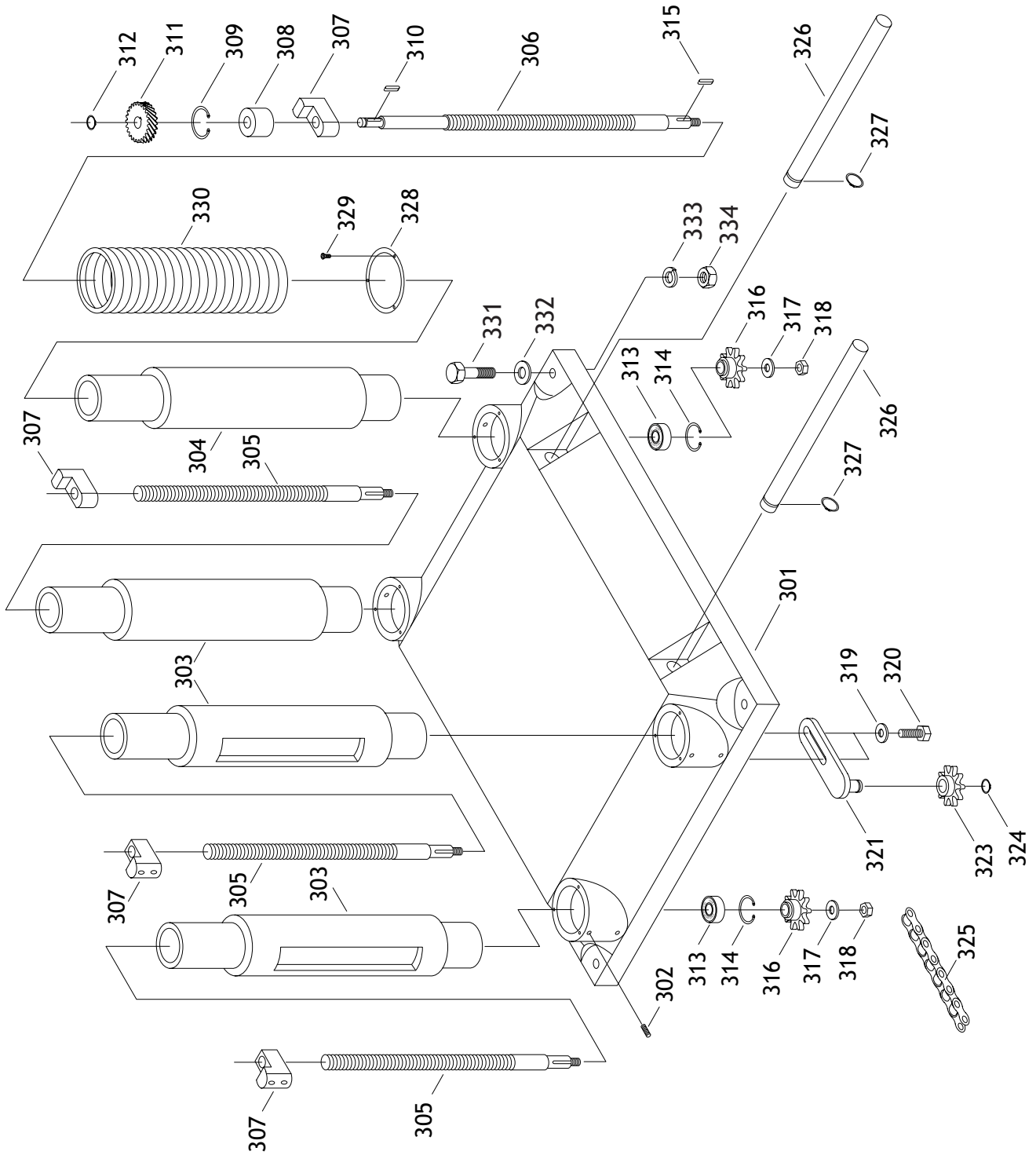
The Model W1683 was specifically designed for cutting natural wood stock. **DO NOT MODIFY AND/OR USE THIS PLANER FOR ANY OTHER PURPOSE.** Modifications or improper use of this tool will void the warranty. If you are confused about any aspect of this machine, **DO NOT** use it until all your questions have been answered.

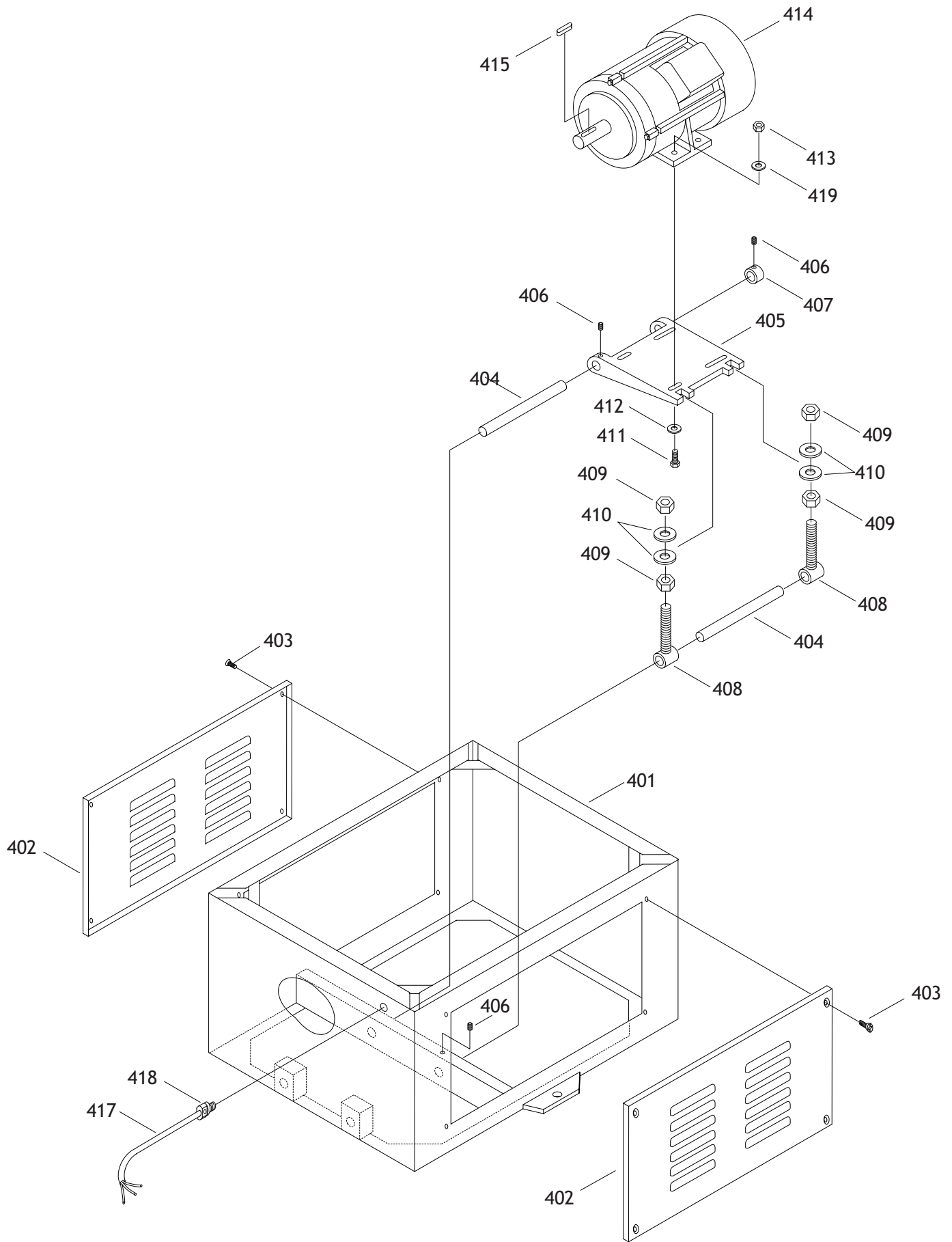


REF	PART #	DESCRIPTION
01	X1683001	HEADCASTING
02	XPSS13M	SETSCREW M10-1.5 X 12
03	X1683003	CUTTERHEAD
04	X1683004	SPRING
05	X1683005	BLADES FOR PLANER
06	X1683006	GIB
07	XPB17M	HEX BOLT M8-1.25 X 10
08	X1683008	KNIFE GAUGE W/BAR
09	X1683009	JACK SCREW
12	XP6206	BEARING 6206
13	XPK09M	KEY 8 X 8 X 36
14	X1683014	CUTTERHEAD PULLEY
15	X1683015	SPECIAL WASHER 5/16" X 1 3/16"
16	XPSS12M	SETSCREW M6-1.0 X 25
17	X1683017	MOTOR PULLEY
18	X1683018	INFEED ROLLER
19	X1683019	BUSHING BLOCK
20	X1683020	SPRING
21	X1683021	OILER SETSCREW
22	X1683022	PLATE
23	XPB09M	HEX BOLT M8-1.25 X 20
24	XPSS11M	SETSCREW M6-1.0 X 16
25	XPN01M	HEX NUT M6-1.0
26	XPK21M	KEY 5 X 5 X 23
29	XPB18M	HEX BOLT M6-1.0 X 15
30	X1683030	OUTFEED ROLLER
32	X1683032	LOCKING ROD
33	XPR03M	EXT RETAINING RING 12MM
34	X1683034	CHIP BREAKER
35	XPN09M	HEX NUT M12-1.75
36	X1683036	CHIP BREAKER SPRING
37	XPW03M	FLAT WASHER 6MM
38	XPB02M	HEX BOLT M6-1 X 12
39	X1683039	SHAFT
40	X1683040	BRACKET
41	X1683041	PRESSURE BAR
42	XPLW04M	LOCK WASHER 8MM
43	X1683043	SHAFT
44	XPSS11M	SETSCREW M6-1.0 X 16
46	X1683046	SPRING PLATE
47	X1683047	CHIP DEFLECTOR PLATE
48	X1683048	ANTI-KICKBACK FINGER
49	X1683049	SPACER
50	X1683050	SHAFT
51	XPEC06M	E-CLIP 20MM
52	X1683052	DEPTH LIMITER
53	XPFH02M	FLT HD SCR M6-1.0 X 12
54	X1683054	UPPER COVER
55	X1683055	GASKET

REF	PART #	DESCRIPTION
56	X1683056	DUST HOOD
57	X1683057	ROLLER STAND
58	X1683058	ROLLER
59	XPSB01M	CAP SCREW M6-1.0 X 16
60	X1683060	WORM GEAR BOX
61	XPSB37M	CAP SCREW M6-1.0 X 50
62	X1683062	WORM
63	XP6201	BEARING 6201
64	XPR29M	SNAP RING 32MM
65	XPK05M	KEY 4 X 4 X 10
66	X1683066	HANDWHEEL
67	X1683067	SPECIAL WASHER 1/2" X 1 1/8"
68	X1683068	HANDLE
69	X1683069	SCALE
70	XPS08M	PHLP HD SCR M5-0.8 X 12
73	X1683073	COVER
75	X1683075	SAFETY HATCH
76	XPB04M	HEX BOLT M6-1.0X10
77	X1683077	SAFETY HATCH
78	XPSB11M	CAP SCREW M8-1.25 X 16
79	X1683079	PULLEY GUARD
80	X1683080	STUD
81	XPW07	FLAT WASHER 5/16"
82	XPN02	HEX NUT 5/16" X 18
83	XPVM59	V-BELT M59 3L590
84	X1683084	PULLEY COVER
85	X1683085	KNOB
86	X1683086	SWITCH BRACKET
87	X1683087	MAGNETIC SWITCH
88	XPN06M	HEX NUT M5-0.8
89	X1672123	SHOP FOX PLAQUE
90	X1683090	RIVET
92	X1683092	STRAIN RELIEF
93	X1683093	POWER CORD
94	X1683094	STAR WASHER #10
95	XPSB04M	CAP SCREW M6-1.0 X 10
96	XPSS14M	SETSCREW M8-1.25 X 12
97	X1683097	RETAINER
98	X1683098	COLLAR
100	X1683100	W1683 ID/WARNING LABEL
101	X1677219	READ MANUAL LABEL
102	X1672497	SAFETY GLASSES LABEL
103	X1683103	EAR PROTECTION LABEL
104	X1683104	COVER REMOVAL LABEL
105	X1672498	ELECTRICITY LABEL
107	XPLW03M	LOCK WASHER 6MM
108	XPS09M	PHLP HD SCR M5-0.8 X 10
109	XPSW01-1	SWITCH COVER SCREW

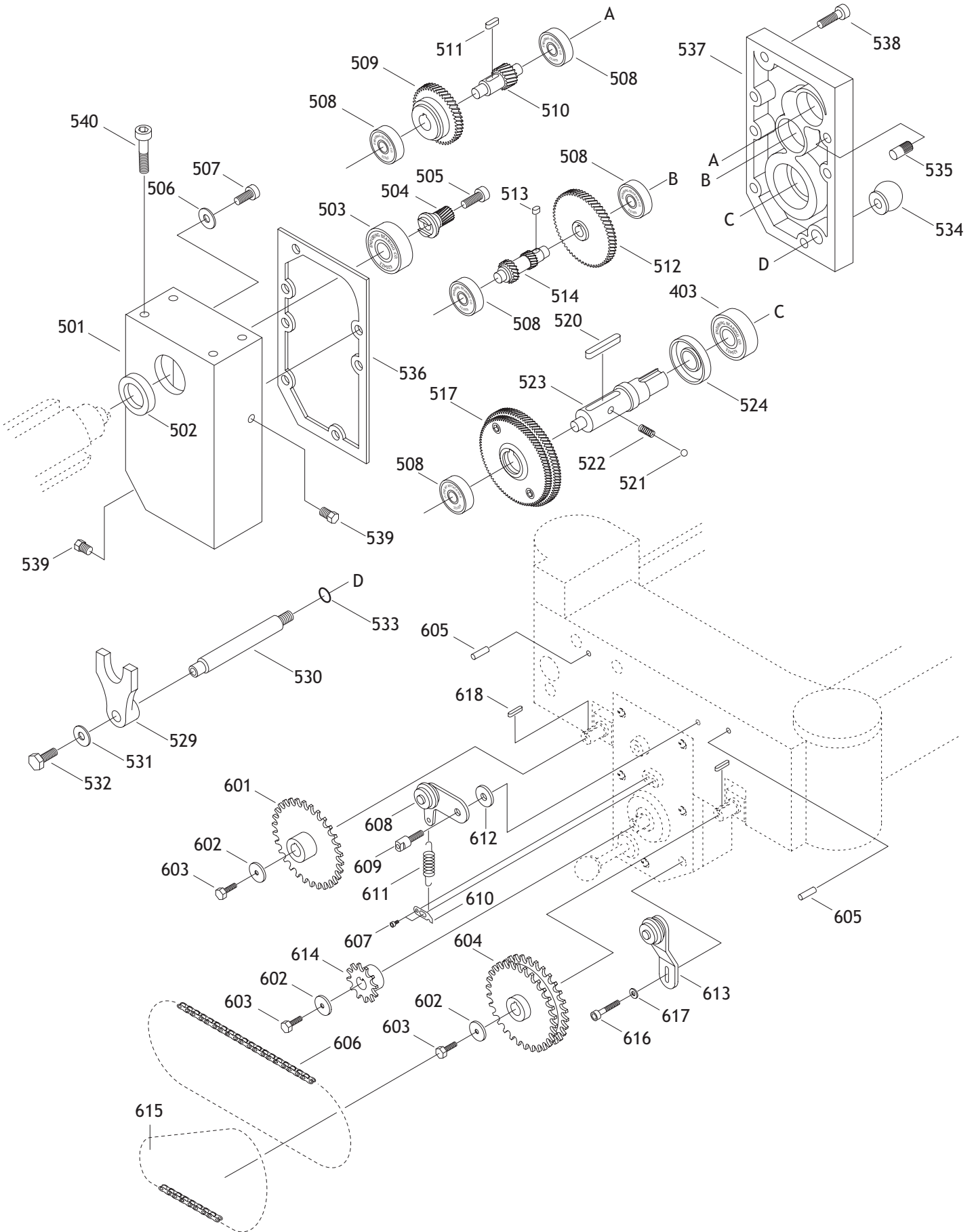






REF	PART #	DESCRIPTION
201	X1683201	MIDDLE TABLE
202	X1683202	ROLLER
203	XP6201	BEARING 6201
204	X1683204	ECCENTRIC SHAFT
205	XPSS04M	SETSCREW M6-1.0 X 12
206	X1683206	THREADED GIB
207	X1683207	LOCK ROD
208	X1683208	GIB
209	X1683209	KNOB
210	XPSB61M	CAP SCREW M10-1.25 X 20
211	X1683211	EXT ROLLER BAR
212	X1683212	EXTENSION ROLLER
213	XPB32M	HEX BOLT M10-1.5 X 25
214	XPW04M	FLAT WASHER 10MM
215	X1683215	POINTER
216	XPSB04M	CAP SCREW M6-1.0 X 10
217	XPLW03M	LOCK WASHER 6MM
301	X1683301	BASE
302	XPSS13M	SETSCREW M10-1.5 X 12
303	X1683303	COLUMN
304	X1683304	COLUMN
305	X1683305	LEADSCREW
306	X1683306	LEADSCREW
307	X1683307	LEADSCREW NUT
308	X1683308	BUSHING
309	XPR22M	INT RETAINING RING 38MM
310	XPK10M	KEY 5 X 5 X 12
311	X1683311	GEAR
312	XPR03M	EXT RETAINING RING 12MM
313	XP6202	BALL BEARING 6202
314	XPR21M	INT RETAINING RING 35MM
315	XPK08M	KEY 5 X 5 X 16
316	X1683316	SPROCKET
317	X1683317	WASHER

REF	PART #	DESCRIPTION
318	XPN08M	HEX NUT M10-1.25
319	XPW01M	FLAT WASHER 8MM
320	XPB07M	HEX BOLT M8-1.25 X 25
321	X1683321	BRACKET W/ SHAFT
323	X1683323	SPROCKET
324	XPR05M	SNAP RING 15MM
325	X1683325	CHAIN
326	X1683326	CRANE POST
327	XPR08M	EXT RETAINING RING 19MM
328	X1683328	PIPE BAND
329	PHTEK5	TAP SCREW 10-24 X 1/2"
330	X1683330	EXPANSION BAND
331	XPB33M	HEX BOLT M12-1.75 X 50
332	XPW06M	FLAT WASHER 12MM
333	XPLW05M	LOCK WASHER 12MM
334	XPN09M	HEX NUT M12-1.75
401	X1683401	STAND
402	X1683402	COVER
403	XPFH06M	FLAT HD SCREW M6-1.0 X 20
404	X1683404	BAR
405	X1683405	MOTOR MOUNT
406	XPSS20M	SETSCREW M8-1.25 X 8
407	X1683407	COLLAR
408	X1683408	ADJUSTABLE BOLT
409	XPN09M	HEX NUT M12-1.75
410	XPW01	FLAT WASHER 1/2"
411	XPB07M	HEX BOLT M8-1.25 X 25
412	X1683412	SPECIAL WASHER 5/16" X 7/8"
413	XPN03M	HEX NUT
414	X1683414	5HP MOTOR
415	XPK36M	KEY 5 X 5 X 50
417	X1683417	POWER CORD
418	X1683418	STRAIN RELIEF
419	XPW01M	FLAT WASHER 8MM



REF	PART #	DESCRIPTION
501	X1683501	GEAR BOX
502	X1683502	OIL SEAL 28-40-8
503	XP6204	BALL BEARING 6204
504	X1683503	GEAR
505	XPSB02M	CAP SCREW M6-1.0 X 20
506	X1683506	SPECIAL WASHER 1/4" X 7/8"
507	XPSB28M	CAP SCREW M6-1.0 X 15
508	XP6201	BALL BEARING 6201
509	X1683509	GEAR
510	X1683510	GEAR AND SHAFT
511	XPK10M	KEY 5 X 5 X 12
512	X1683512	GEAR
513	XPK06M	KEY 5 X 5 X 10
514	X1683514	GEAR, 2-SPEED
517	X1683517	DOUBLE GEAR
520	XPK11M	KEY 6 X 6 X 40
521	X1683521	BALL 6MM
522	X1683522	SPRING
523	X1683523	SHAFT
524	X1683524	OIL SEAL 25 X 47 X 7
529	X1683529	SHIFTER
530	X1683530	SHIFTING SHAFT HANDLE
531	XPW03M	FLAT WASHER 6MM
532	XPB02M	HEX BOLT M6-1.0 X 12
533	X1683533	O-RING 12MM

REF	PART #	DESCRIPTION
534	X1683534	KNOB
535	X1683535	PIN
536	X1683536	GASKET
537	X1683537	GEAR CASE
538	XPSB06M	CAP SCREW M6-1.0 X 25
539	X1683539	OIL PLUG
540	XPSB05M	CAP SCREW M8-1.25 X 50
601	X1683601	SPROCKET
602	X1683602	SPECIAL WASHER 1/4" X 7/8"
603	XPSB18M	CAP SCREW M4-0.7 X 8
604	X1683604	SPROCKET
605	XPRP07M	ROLL PIN 6X20
606	X1683606	CHAIN 33 LINKS
607	XPSB04M	CAP SCREW M6-1.0 X 10
608	X1683608	CHAIN TENSIONER
609	X1683609	SHAFT
610	X1683610	HANGER
611	X1683611	SPRING
612	X1683612	SPACER
613	X1683613	OUTER CHAIN TENSIONER
614	X1683614	SPROCKET
615	X1683615	CHAIN 25 LINKS
616	XPSB48M	CAP SCREW M6-1.0 X 35
617	XPW03M	FLAT WASHER 6MM



WARRANTY CARD

Name _____
 Street _____
 City _____ State _____ Zip _____
 Phone Number _____ E-Mail _____ FAX _____
MODEL # W1683 20" Planer SERIAL#

The following information is given on a voluntary basis and is strictly confidential.

- Where did you purchase your Shop Fox® machine?

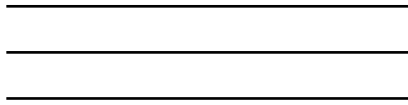
- How did you first learn about us?
 Advertisement Friend
 Mail order Catalog Local Store
 World Wide Web Site
 Other _____
- Which of the following magazines do you subscribe to.
 American Woodworker Today's Homeowner
 Cabinetmaker WOOD
 Family Handyman Wooden Boat
 Fine Homebuilding Woodshop News
 Fine Woodworking Woodsmith
 Home Handyman Woodwork
 Journal of Light Construction Woodworker
 Old House Journal Woodworker's Journal
 Popular Mechanics Workbench
 Popular Science American How-To
 Popular Woodworking
 Other _____
- Which of the following woodworking/remodeling shows do you watch?
 Backyard America The New Yankee Workshop
 Home Time This Old House
 The American Woodworker Woodwright's Shop
 Other _____
- What is your annual household income?
 \$20,000-\$29,999 \$60,000-\$69,999
 \$30,000-\$39,999 \$70,000-\$79,999
 \$40,000-\$49,999 \$80,000-\$89,999
 \$50,000-\$59,999 \$90,000 +
- What is your age group?
 20-29 50-59
 30-39 60-69
 40-49 70 +
- How long have you been a woodworker?
 0 - 2 Years 8 - 20 Years
 2 - 8 Years 20+ Years
- How would you rank your woodworking skills?
 Simple Advanced
 Intermediate Master Craftsman
- How many Shop Fox® machines do you own? _____
- What stationary woodworking tools do you own? Check all that apply.
 Air Compressor Panel Saw
 Band Saw Planer
 Drill Press Power Feeder
 Drum Sander Radial Arm Saw
 Dust Collector Shaper
 Horizontal Boring Machine Spindle Sander
 Jointer Table Saw
 Lathe Vacuum Veneer Press
 Mortiser Wide Belt Sander
 Other _____
- Which benchtop tools do you own? Check all that apply.
 1" x 42" Belt Sander 6" - 8" Grinder
 5" - 8" Drill Press Mini Lathe
 8" Table Saw 10" - 12" Thickness Planer
 8" - 10" Bandsaw Scroll Saw
 Disc/Belt Sander Spindle/Belt Sander
 Mini Jointer
 Other _____
- Which portable/hand held power tools do you own? Check all that apply.
 Belt Sander Orbital Sander
 Biscuit Joiner Palm Sander
 Circular Saw Portable Planer
 Detail Sander Saber Saw
 Drill/Driver Reciprocating Saw
 Miter Saw Router
 Other _____
- What machines/supplies would you like to see?

- What new accessories would you like Woodstock International to carry?

- Do you think your purchase represents good value?
 Yes No
- Would you recommend Shop Fox® products to a friend?
 Yes No
- Comments: _____

CUT ALONG DOTTED LINE

FOLD ALONG DOTTED LINE



Place
Stamp
Here



WOODSTOCK INTERNATIONAL, INC.
P.O. BOX 2309
BELLINGHAM, WA 98227-2309



FOLD ALONG DOTTED LINE

TAPE ALONG EDGES--PLEASE DO NOT STAPLE

