

Grizzly *Industrial, Inc.*®

WOOD LATHE MODEL G1067Z INSTRUCTION MANUAL



COPYRIGHT © 1996 BY GRIZZLY INDUSTRIAL, INC. REVISED JULY, 2009 (TR)
**WARNING: NO PORTION OF THIS MANUAL MAY BE REPRODUCED IN ANY SHAPE
OR FORM WITHOUT THE WRITTEN APPROVAL OF GRIZZLY INDUSTRIAL, INC.**
#5983 PRINTED IN TAIWAN.

WARNING

Some dust created by power sanding, sawing, grinding, drilling, and other construction activities contains chemicals known to the State of California to cause cancer, birth defects or other reproductive harm. Some examples of these chemicals are:

- Lead from lead-based paints.
- Crystalline silica from bricks, cement, and other masonry products.
- Arsenic and chromium from chemically treated lumber.

Your risk from these exposures varies, depending on how often you do this type of work. To reduce your exposure to these chemicals: work in a well ventilated area, and work with approved safety equipment, such as those dust masks that are specially designed to filter out microscopic particles.

Table Of Contents

SECTION 1: SAFETY	2
Safety Instructions For Power Tools	2
Additional Safety Instructions For The Lathe.....	4
SECTION 1: INTRODUCTION	5
Commentary.....	5
Unpacking	6
Piece Inventory	6
Site Considerations	7
Clean Up	7
Circuit Requirements	8
Grounding	9
Extension Cords.....	9
SECTION 2: ASSEMBLY	10
Pre-assembly	10
Stand	10
Installing the Switch	11
Tool Rest	12
Tailstock.....	12
Spur Center	13
Face Plate	13
SECTION 3: ADJUSTMENTS	14
Headstock	14
Tailstock.....	15
Live Center.....	16
Speed Selector.....	16
SECTION 4: OPERATIONS	17
Test Run.....	17
Tool Rest	17
Spindle Turning	18
Outboard Turning	19
Indexing	19
SECTION 5: MAINTENANCE	20
General	20
Bed.....	20
Lubrication	20
SECTION 6: CLOSURE	21
Machine Data Sheet	22
Parts Breakdown	23
Parts List	25
Warranty & Returns	26

SECTION 1: SAFETY

WARNING

For Your Own Safety Read Instruction Manual Before Operating This Equipment

The purpose of safety symbols is to attract your attention to possible hazardous conditions. This manual uses a series of symbols and signal words which are intended to convey the level of importance of the safety messages. The progression of symbols is described below. Remember that safety messages by themselves do not eliminate danger and are not a substitute for proper accident prevention measures.



Indicates an imminently hazardous situation which, if not avoided, WILL result in death or serious injury.



Indicates a potentially hazardous situation which, if not avoided, COULD result in death or serious injury.



Indicates a potentially hazardous situation which, if not avoided, MAY result in minor or moderate injury. It may also be used to alert against unsafe practices.

NOTICE

This symbol is used to alert the user to useful information about proper operation of the equipment.

WARNING

Safety Instructions For Power Tools

- KEEP GUARDS IN PLACE** and in working order.
- REMOVE ADJUSTING KEYS AND WRENCHES.** Form a habit of checking to see that keys and adjusting wrenches are removed from tool before turning on.
- KEEP WORK AREA CLEAN.** Cluttered areas and benches invite accidents.
- NEVER USE IN DANGEROUS ENVIRONMENT.** DO NOT use power tools in damp or wet locations, or where any flammable or noxious fumes may exist. Keep work area well lighted.
- KEEP CHILDREN AND VISITORS AWAY.** All children and visitors should be kept at a safe distance from work area.
- MAKE WORKSHOP CHILD PROOF** with padlocks, master switches, or by removing starter keys.
- NEVER FORCE TOOL.** It will do the job better and safer at the rate for which it was designed.
- USE RIGHT TOOL.** DO NOT force tool or attachment to do a job for which it was not designed.

WARNING

Safety Instructions For Power Tools

9. USE PROPER EXTENSION CORD. Make sure your extension cord is in good condition. Conductor size should be in accordance with the chart below. The amperage rating should be listed on the motor or tool nameplate. An undersized cord will cause a drop in line voltage resulting in loss of power and overheating. Your extension cord must also contain a ground wire and plug pin. Always repair or replace extension cords if they become damaged.

Minimum Gauge for Extension Cords

AMP RATING	LENGTH		
	25ft	50ft	100ft
0-6	16	16	16
7-10	16	16	14
11-12	16	16	14
13-16	14	12	12
17-20	12	12	10
21-30	10	10	No

10. WEAR PROPER APPAREL. DO NOT wear loose clothing, gloves, neckties, rings, bracelets, or other jewelry which may get caught in moving parts. Non-slip footwear is recommended. Wear protective hair covering to contain long hair.

11. ALWAYS USE SAFETY GLASSES. Also use face or dust mask if cutting operation is dusty. Everyday eyeglasses only have impact resistant lenses, they are NOT safety glasses.

12. SECURE WORK. Use clamps or a vise to hold work when practical. It's safer than using your hand and frees both hands to operate tool.

13. DO NOT OVER-REACH. Keep proper footing and balance at all times.

14. MAINTAIN TOOLS WITH CARE. Keep tools sharp and clean for best and safest performance. Follow instructions for lubricating and changing accessories.

15. USE RECOMMENDED ACCESSORIES. Consult the owner's manual for recommended accessories. The use of improper accessories may cause risk of injury.

16. REDUCE THE RISK OF UNINTENTIONAL STARTING. On machines with magnetic contact starting switches there is a risk of starting if the machine is bumped or jarred. Always disconnect from power source before adjusting or servicing. Make sure switch is in OFF position before reconnecting.

17. CHECK DAMAGED PARTS. Before further use of the tool, a guard or other part that is damaged should be carefully checked to determine that it will operate properly and perform its intended function. Check for alignment of moving parts, binding of moving parts, breakage of parts, mounting, and any other conditions that may affect its operation. A guard or other part that is damaged should be properly repaired or replaced.

18. NEVER LEAVE TOOL RUNNING UNATTENDED. TURN POWER OFF. DO NOT leave tool until it comes to a complete stop.

19. NEVER OPERATE A MACHINE WHEN TIRED, OR UNDER THE INFLUENCE OF DRUGS OR ALCOHOL. Full mental alertness is required at all times when running a machine.

20. NEVER ALLOW UNSUPERVISED OR UNTRAINED PERSONNEL TO OPERATE THE MACHINE. Make sure any instructions you give in regards to machine operation are approved, correct, safe, and clearly understood.

21. IF AT ANY TIME YOU ARE EXPERIENCING DIFFICULTIES performing the intended operation, stop using the machine! Then contact our service department or ask a qualified expert how the operation should be performed.

WARNING

Additional Safety Instructions For The Lathe

1. **MAKE SURE ALL GUARDS** are in place and that the Lathe sits on a flat, stable surface.
2. **ALWAYS WEAR EYE PROTECTION** or a face shield when operating the Lathe. All safety equipment should be ANSI approved.
3. **USE A RESPIRATOR TO AVOID INHALING DUST.** All safety equipment should be ANSI approved.
4. **BEFORE STARTING THE MACHINE** be certain the workpiece has been properly imbedded on the headstock and tailstock centers and that there is adequate clearance for the full rotation.
5. **ADJUST TOOL REST** to provide proper support for the turning tool you will be using. Test tool rest clearance by rotating workpiece by hand before turning lathe on.
6. **SELECT THE TURNING SPEED** which is appropriate for the type of work. Allow the lathe to gain its full speed before using.
7. **ALWAYS INSPECT THE CONDITION** of the materials you are turning. Do not turn pieces with knots, splits and other potentially dangerous conditions.
8. **KEEP LATHE TOOLS PROPERLY SHARPENED** and hold firmly in the proper position when turning.
9. **NEVER OPERATE THE LATHE WITH DAMAGED OR WORN PARTS.** Maintain your lathe in proper working condition.
10. **MAKE SURE YOUR WOOD LATHE IS TURNED OFF**, disconnected from its power source and all moving parts have come to a complete stop before starting any inspection, adjustment, or maintenance procedure.
11. **DO NOT LEAVE LATHE RUNNING UNATTENDED** for any reason.
12. **DO NOT STOP LATHE USING YOUR HAND** against the workpiece.
13. **KEEP LOOSE CLOTHING ARTICLES** such as sleeves, belts and jewelry items away from the lathe spindle.
14. **WHEN FACE PLATE TURNING**, use lathe chisels on the downward spinning side of the workpiece only.
15. **REMOVE THE TOOL REST** when performing sanding or polishing operations on the rotating spindle.
16. **ATTEMPTING TO REMOVE** too much material at once may cause work material to fly out of the lathe.
17. **THE JOINTS OF GLUED-UP WORKPIECES** should be high quality to prevent them from breaking under the extreme forces of lathe turning. Consult in-depth trade manuals and instructional books for correct techniques when gluing up a workpiece from multiple pieces. If a joint fails during a lathe turning operation, serious injury or death could occur.

WARNING

Like all machines there is danger associated with the Model G1067Z. Accidents are frequently caused by lack of familiarity or failure to pay attention. Use this machine with respect and caution to lessen the possibility of operator injury. If normal safety precautions are overlooked or ignored, serious personal injury may occur.

CAUTION

No list of safety guidelines can be complete. Every shop environment is different. Always consider safety first, as it applies to your individual working conditions. Use this and other machinery with caution and respect. Failure to do so could result in serious personal injury, damage to equipment, or poor work results.

SECTION 1: INTRODUCTION

Commentary

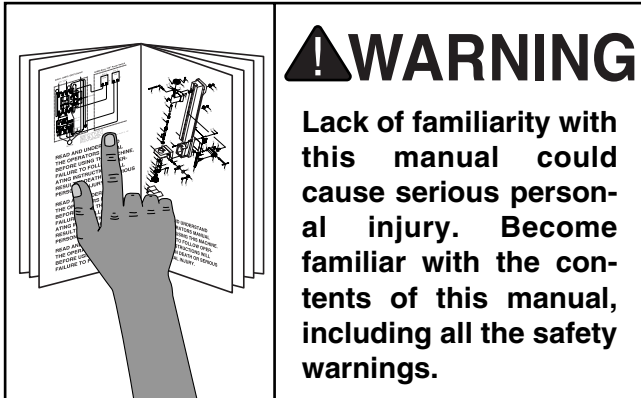

We are proud to offer the Model G1067Z. This machine is part of a growing Grizzly family of fine woodworking machinery. When used according to the guidelines set forth in this manual, you can expect years of trouble-free, enjoyable operation and proof of Grizzly's commitment to customer satisfaction.

We are pleased to provide this manual with the Model G1067Z. It was written to guide you through assembly, review safety considerations, and cover general operating procedures. It represents our effort to produce the best documentation possible. If you have any comments regarding this manual, please write to us at the address below:

Grizzly Industrial, Inc.
c/o Technical Documentation
P.O. Box 2069
Bellingham, WA 98227-2069

Most importantly, we stand behind our machines. If you have any service questions or parts requests, please call or write us at the location listed below.

Grizzly Industrial, Inc.
1203 Lycoming Mall Circle
Muncy, PA 17756
Phone: (570) 546-9663
Fax: (800) 438-5901
E-Mail: techsupport@grizzly.com
Web Site: <http://www.grizzly.com>

The specifications, drawings, and photographs illustrated in this manual represent the Model G1067Z as supplied when the manual was prepared. However, owing to Grizzly's policy of continuous improvement, changes may be made at any time with no obligation on the part of Grizzly. For your convenience, we always keep current Grizzly manuals available on our website at www.grizzly.com. Any updates to your machine will be reflected in these manuals as soon as they are complete. Visit our site often to check for the latest updates to this manual!



Unpacking

The Model G1067Z Wood Lathe is shipped from the manufacturer in a carefully packed carton. If you discover the machine is damaged after you've signed for delivery, *please call Customer Service immediately for advice.*

Save the containers and all packing materials for possible inspection by the carrier or its agent. *Otherwise, filing a freight claim can be difficult.*

When you are completely satisfied with the condition of your shipment, you should inventory its parts.

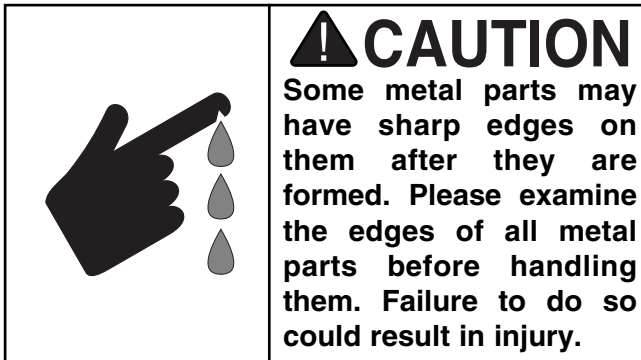
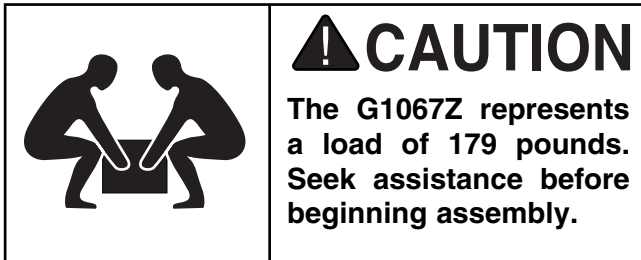

Piece Inventory

After all the parts have been removed from the carton, you should have:

- Main Lathe Unit
- Grizzly Paddle Switch
- Front/Rear Covers
- Index Pin
- 6" Face Plate
- 12" Tool Rest
- Tool Rest Support
- Tool Rest Extension
- Knock Out Bar
- Stand Legs (4)
- Stand Support, Long (2)
- Stand Support, Short (2)
- Upper Mount Plate (2)
- End Stand Support (2)

Fasteners:

- | | |
|---|----|
| • Carriage Bolt $\frac{5}{16}$ " - 18 x $\frac{3}{4}$ " | 24 |
| • Flat Washer $\frac{5}{16}$ " | 24 |
| • Cap Screw $\frac{5}{16}$ " - 18 x 1" | 8 |
| • Hex Nut $\frac{5}{16}$ " - 18 | 32 |
| • Phillips Head Screw 10 - 24 x $\frac{3}{8}$ " | 12 |
| • Lock Washer $\frac{5}{16}$ " | 8 |

In the event that any non proprietary parts are missing (e.g. a nut or a washer...), we would be glad to replace them, or, for the sake of expediency, replacements can be obtained at your local hardware store.



Site Considerations

Floor Load

The Model G1067Z weighs 179 lbs. Most commercial floors are suitable for your machine. Some floors may require additional reinforcement to support the machine, the operator, and the workpiece.

Working Clearances

Consider existing and anticipated needs, size of material to be processed through each machine, and space for auxiliary stands, work tables or other machinery when establishing a location for your machine.

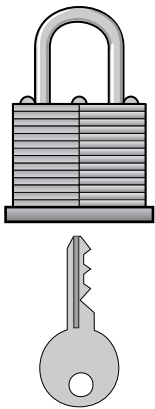
	<p>!WARNING</p> <p>Unsupervised children and visitors inside your shop could receive serious personal injury. Ensure child and visitor safety by keeping all entrances to the shop locked at all times. DO NOT allow unsupervised children or visitors in the shop at any time.</p>
--	---



Clean Up

The unpainted surfaces are coated with a waxy oil to protect them from corrosion during shipment. Remove this protective coating with a solvent cleaner or citrus-based degreaser such as Grizzly's G7895 Degreaser. To clean thoroughly, some parts may need to be removed. **For optimum performance from your machine, make sure you clean all moving parts or sliding contact surfaces that are coated.** Avoid chlorine-based solvents as they may damage painted surfaces should they come in contact.

	<p>!WARNING</p> <p>Gasoline and petroleum products have low flash points and could explode if used to clean machinery. DO NOT use gasoline or petroleum products to clean the machinery.</p>
---	--

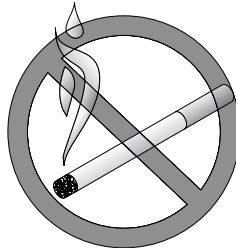
	<p>!WARNING</p> <p>Smoking near solvents could ignite an explosion or fire and cause serious injury. DO NOT smoke while using solvents.</p>
--	---

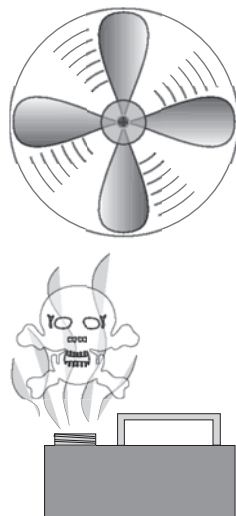
	<p>!WARNING</p> <p>Lack of ventilation while using solvents could cause serious personal health risks, fire, or environmental hazards. Always work in a well ventilated area to prevent the accumulation of dangerous fumes. Supply the work area with a constant source of fresh air.</p>
--	---



Circuit Requirements

Amperage Draw

The Model G1067Z motor is wired to operate at 110V and will draw the following load:

Motor Load8 Amps

Plug Type

The Model G1067Z is supplied with a NEMA 5-15 plug. DO NOT modify the plug or power cord in any way. See **Figure 1** for a NEMA 5-15 plug and grounded outlet.

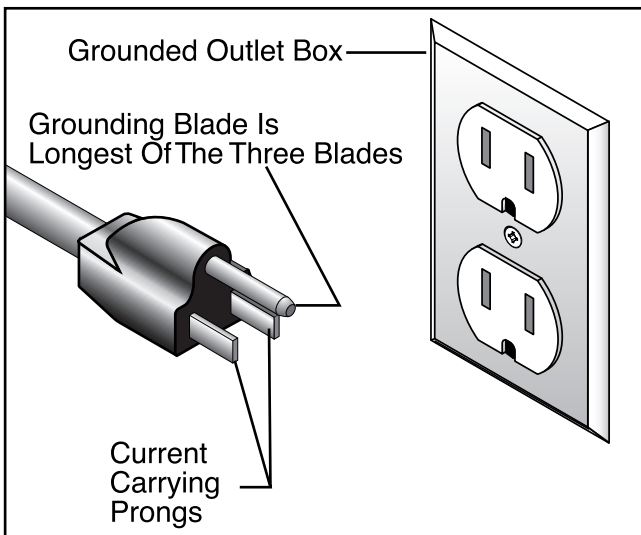

Figure 1. NEMA 5-15 plug and grounded outlet.

Circuit Breaker Requirements

We recommend that the circuit you use your machine on should be dedicated. Because the machine motors are different sizes, please use the following guidelines when choosing a circuit breaker for your machine (circuit breakers rated any higher are not adequate to protect the circuit):

Recommended Circuit Breaker15 Amp

Your Circuit Capacity

Always check to see if the wires in your circuit are capable of handling the amperage load from your machine. If you are unsure, consult a qualified electrician.

If you operate this machine on any circuit that is already close to its capacity, it might blow a fuse or trip a circuit breaker. However, if an unusual load does not exist and a power failure still occurs, contact a qualified electrician or our Service Department at (570) 546-9663.

!WARNING

Serious personal injury could occur if you connect your machine to the power source before you have completed the assembly process. DO NOT connect the machine to the power source until instructed to do so.



Grounding

In the event of an electrical short, grounding reduces the risk of electric shock by providing a path of least resistance to disperse electric current. This tool is equipped with a power cord that has an equipment-grounding prong. The outlet must be properly installed and grounded in accordance with all local codes and ordinances.

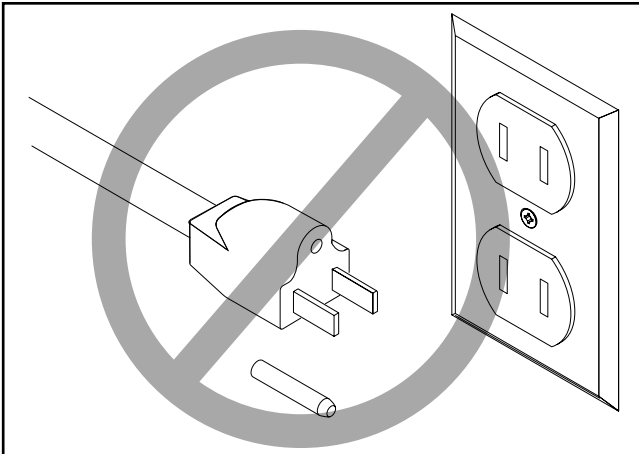
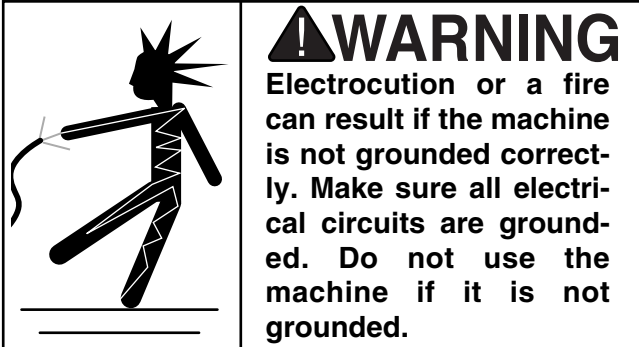

! CAUTION

This machine must have a ground prong in the plug to help ensure that it is grounded. DO NOT remove ground prong from plug to fit into a two-pronged outlet! If the plug will not fit the outlet, have the proper outlet installed by a qualified electrician.

NOTICE

The wire on the power cord with green or green and yellow striped insulation is the grounding conductor.



Extension Cords

110V Operation

If you find it necessary to use an extension cord at 110V:

- Make sure the cord is rated Standard Service (grade S) or better.
- The extension cord must also contain a ground wire and plug pin.
- Use at least a 16 gauge cord if the cord is 50 feet long or less.
- DO NOT use a cord longer than 100 feet!



! CAUTION

No single list of electrical guidelines can be comprehensive for all shop environments. Operating this machinery may require additional electrical upgrades specific to your machine and shop environment. It is your responsibility to make sure your electrical systems comply with all local electrical codes and ordinances.

SECTION 2: ASSEMBLY

Pre-assembly

Assembly of the G1067Z is straightforward. We have organized the assembly process into steps. Please follow them in sequence.

Tools Required: Only a few common tools are needed to assemble this machine. Specifically, a 6" adjustable wrench, 12mm open end wrench, regular and Phillips head screwdriver and an 8mm Hex wrench.

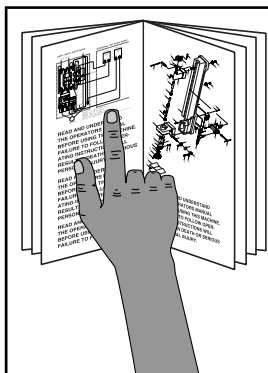

! WARNING

This machine presents serious injury hazards to untrained users. Read through this entire manual to become familiar with the controls and operations before starting the machine!

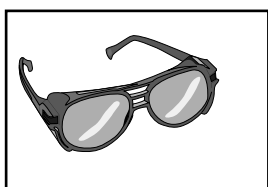

! WARNING

Wear safety glasses during the entire set up process!



Stand

1. Locate all four stand legs and the two end panels. Attach an end panel to any two of the legs using the 10-24 x $\frac{3}{8}$ " Phillips head screws provided (**Figure 1**). Repeat this step for the remaining end panel/legs. DO NOT final tighten the bolts at this time.

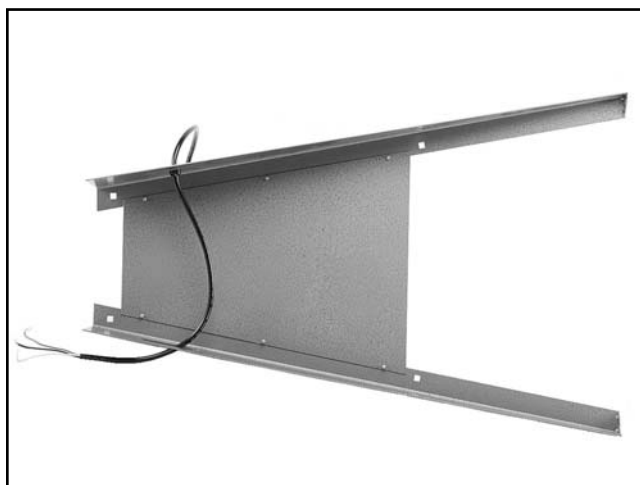

Figure 1.

2. Bolt the upper mount plate and the short stand support to each end assembly using the $\frac{5}{16}$ "-18 x $\frac{3}{4}$ " carriage bolts provided (**Figure 2**).

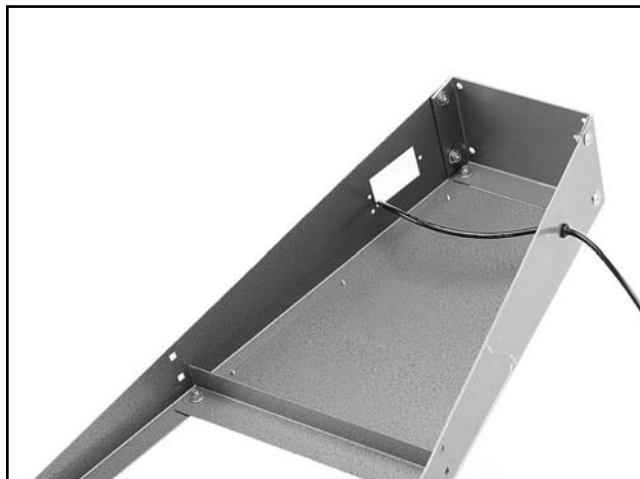

Figure 2.

3. Attach the long stand supports to each end assembly using the $\frac{5}{16}$ "-18 x $\frac{3}{4}$ " carriage bolts provided (**Figure 3**).



Figure 3.

4. With an assistant, set the lathe bed assembly on the stand, orienting the front of the headstock with the switch opening in the stand leg. Bolt the lathe bed to the stand using the eight $\frac{5}{16}$ "-18 x 1 cap screws and hex nuts supplied and tighten down (**Figure 4**).

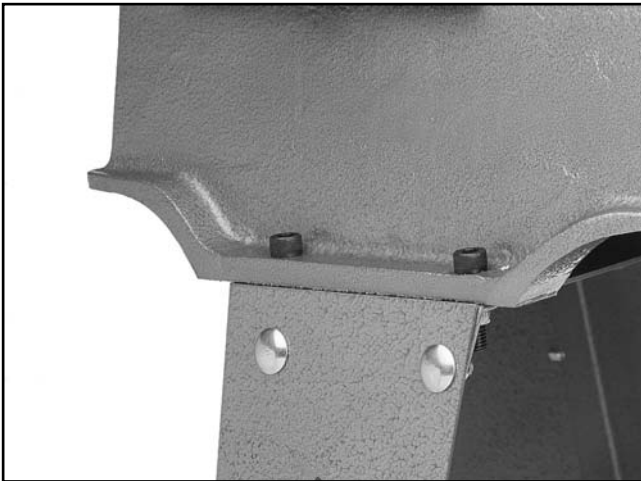

Figure 4.

5. At this point tighten down all the bolts on the stand. It is a good idea to do this with the lathe set in place where it will be used.



Installing the Switch

!WARNING

Do not plug cord in until you are ready to test run the lathe. See Test Run section for instructions before initial run.

1. Locate the paddle switch.
2. Press the paddle switch into the cut-out on the face of the leg as shown in **Figure 5**.



Figure 5.

3. Attach the power wires to the back of the paddle switch as shown in **Figure 6**. Note—*The green ground wire MUST be securely attached to the sheet metal leg.*



Figure 6.

Note—The paddle switch is equipped with a removable safety key (**Figure 7**). When the lathe is not be in use, the safety key should be removed from the paddle switch and placed in a safe location. The lathe cannot be turned on when the safety key is removed from the paddle switch.



Figure 7.



Tool Rest

The tool rest is equipped with a cam-action clamping system to secure it to the lathe bed. To install the tool rest assembly:

1. Remove the large hex nut and lock plate from the bottom of the tool rest assembly.
2. Set the tool rest assembly on the lathe bed with the clamp stud between the bed slot.
3. Set the tool rest lock handle so it is pointing down. Re-install the lock plate and thread the hex nut back onto the stud until it bottoms out.
4. Lift the lock handle approximately 90° and tighten the hex nut $\frac{1}{2}$ to $\frac{2}{3}$ of a turn more.
5. Turn the tool rest lock handle until it locks the tool rest down onto the bed. You may need to adjust the hex nut in small increments to fine tune how the tool rest assembly locks down onto the bed.



Figure 8.



Tailstock

Thread the handle onto the tailstock handwheel and tighten down the jam nut (**Figure 9**).



Figure 9.



Spur Center

The G1067Z is supplied with a #2 Morse taper spur center for use when spindle turning. The spur center is used in conjunction with the tailstock live center. Install the spur center by inserting into the hole in the inboard spindle (**Figure 10**).



Figure 10.

To remove: insert the knockout bar provided into the outboard spindle and tap with the palm of your hand while carefully holding onto the spur center with your other hand (**Figure 11**).

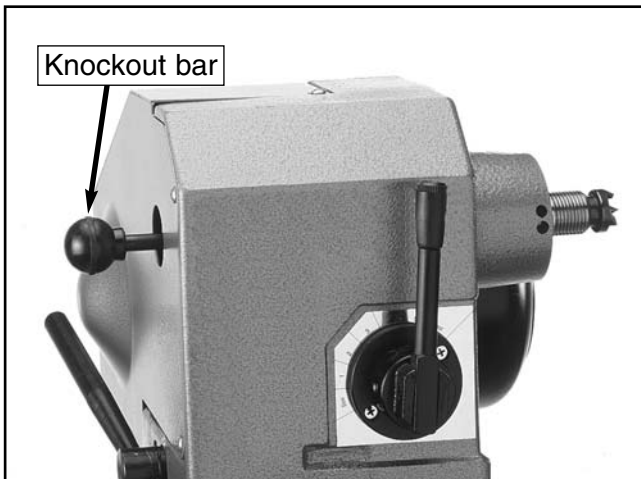

Figure 11.



Face Plate

The G1067Z is supplied with a 6" face plate. The faceplate is used for bowl and plate turning. Install the face plate by threading the face plate onto the inboard spindle. Use the indexing pin to hold the spindle from rotating while tightening down or removing the face plate (**Figure 12**). DO NOT use the face plate in conjunction with the spur center. Mount your workpiece to the face plate using the mounting holes bored into the face plate.

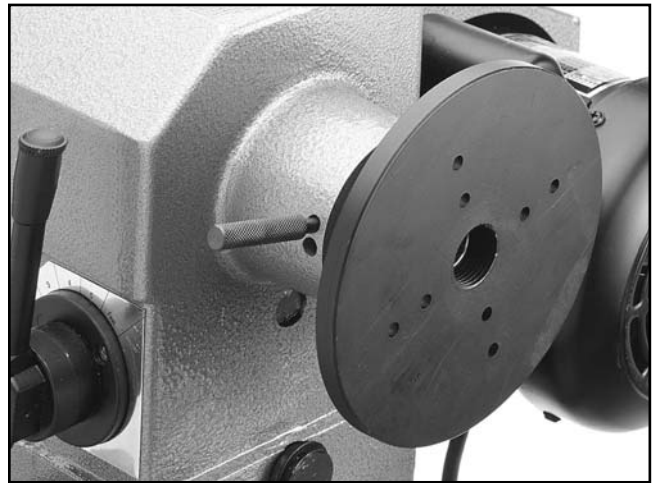

Figure 12.

⚠ WARNING

The contact area between the workpiece and the face plate must be flush with one another. Failure to do this could result in the face plate distorting or breaking when it is screwed to the workpiece, or during use, causing injury or death.

⚠ WARNING

The joints of glued-up workpieces should be high quality to prevent them from breaking under the extreme forces of lathe turning. Consult in-depth trade manuals and instructional books for correct techniques when gluing up a workpiece from multiple pieces. If a joint fails during a lathe turning operation, serious injury or death could occur.



SECTION 3: ADJUSTMENTS

Headstock

The Model G1067Z headstock can be swiveled 180° as well as positioned anywhere along the bed.

1. Loosen the quick release lever by pushing it down (**Figure 13**).
2. Move the headstock to the desired position and re-engage the quick release lever (**Figure 14**). Note—*The large hex nut under the headstock will require occasional adjusting to assure proper clamping pressure to the bed. Turn the hex nut in small increments to fine tune the clamping pressure.*



Figure 13.

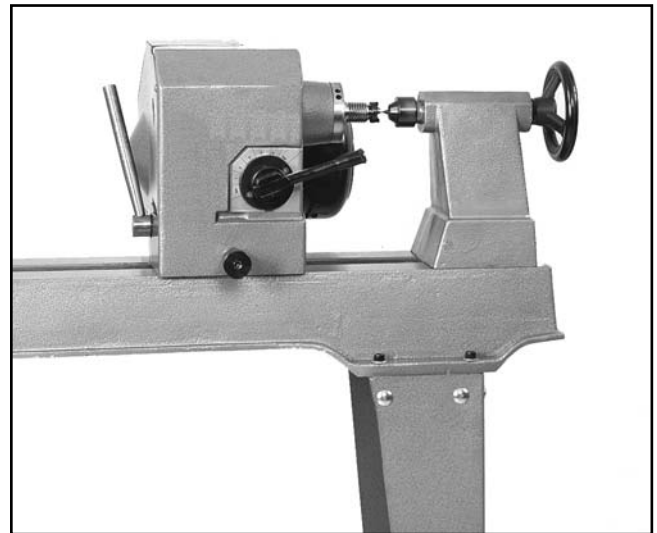

Figure 14.

1. Loosen the quick release lever by pushing it down.
2. Pull the spring loaded quick release set pin (**Figure 15**) and rotate the headstock clockwise 90° or 180°.

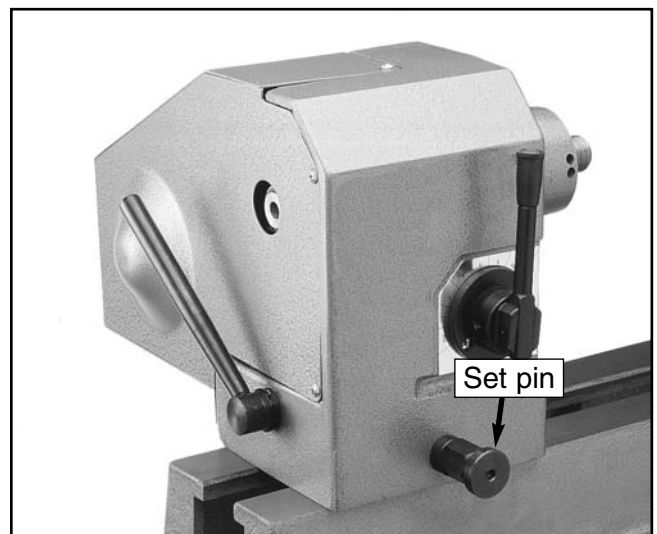

Figure 15.

3. Release the set pin. Make sure the set pin has engaged in its detent by trying to rotate the headstock.
4. Now position the head stock along the bed as desired and engage the quick release lever.

!WARNING

Never operate the lathe with the quick release lever loose. Serious personal injury may occur.

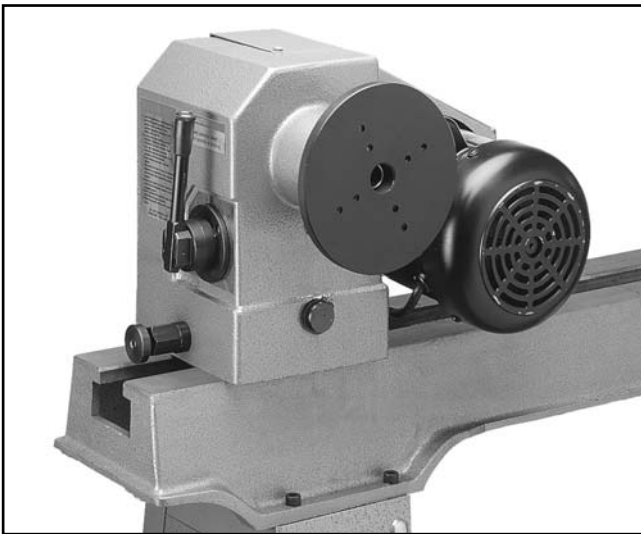

Figure 16. Headstock set at 90°.



Figure 17. Headstock set at 180°.



Tailstock

The tailstock is equipped with a cam-action clamping system to secure it to the lathe bed. When the lever is thrown, a locking plate lifts up and secures the tool rest to the bed. To position the tailstock along the bed:

1. Loosen the quick release lever and move the tailstock to the desired position (**Figure 18**).
2. Re-engage the quick release lever.
3. If the quick release lever will not lock the tailstock down onto the bed (either too loose or too tight), loosen or tighten the hex nut (located on the underside of the tailstock) in small increments as needed to achieve the proper clamping pressure.



Figure 18.



Live Center

A #2 Morse taper live center is supplied with the lathe and is preinstalled from the factory (**Figure 19**). To remove it:

1. Turn the handwheel counter-clockwise until the tailstock barrel bottoms out in the tailstock housing. This causes the center to be forced out of the barrel.
2. Reinstall by turning the handwheel clockwise until the tailstock barrel sticks out of the tailstock housing about $\frac{1}{2}$ ". Insert the live center back into the tailstock barrel.

!WARNING

(1) The tailstock barrel lock handle (Figure 19) must always be locked down while the lathe is in use. The workpiece can be thrown from the lathe if this step is not observed. (2) The tailstock barrel should not protrude from the tailstock housing more than 2". Serious personal injury may occur.

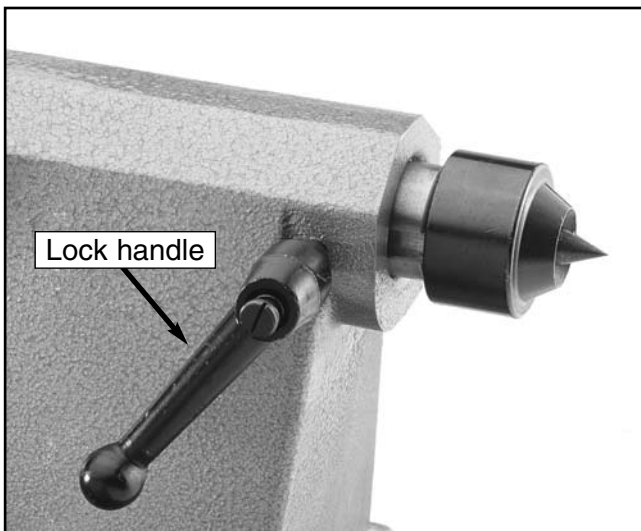

Figure 19.



Speed Selector

!CAUTION

The lathe must be running to change speeds. Before turning the lathe on, read Safety Rules and Test Run in the Operations Section.

The variable speed selector has six position settings. These settings provide speeds of 500, 800, 1200, 1600, 2000 and 2700 RPM for varied applications. To change speeds:

1. Turn the lathe on.
2. Pull the speed selector lever straight back away from the machine so the detent spring compresses (**Figure 20**).
3. Slowly shift the lever to the desired speed.
4. Make sure the lever is set in the detent for the desired speed. The lever should click into position.

!CAUTION

Remember to choose the correct speed for your particular turning project. As a general rule, the larger the workpiece diameter, the slower the speed. Always start on slow speed.

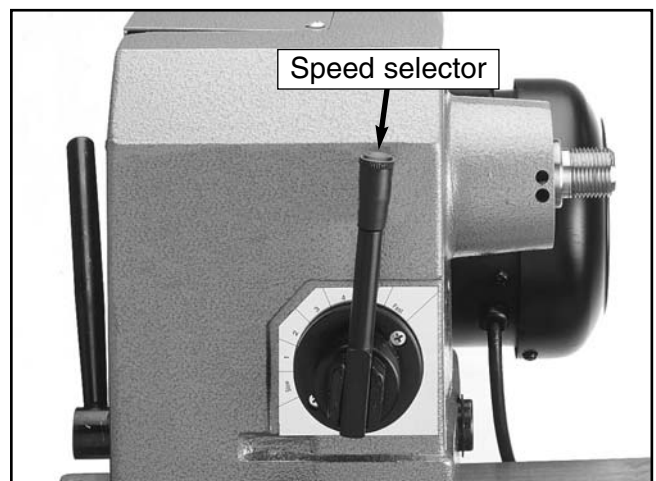

Figure 20.



SECTION 4: OPERATIONS

Test Run

Once the assembly is complete and the adjustments are done to your satisfaction, you are ready to test the machine.

CAUTION

Turn on the power supply at the main panel. Press the **START** button. Make sure that your finger is poised on the **STOP** button, just in case there's a problem. The Wood Lathe should run smoothly, with little or no vibration or rubbing noises. Strange or unnatural noises should be investigated and corrected before operating the machine further.

WARNING

DO NOT attempt to investigate or adjust the machine while it is running. Wait until the machine is turned off, unplugged and all working parts have come to a rest before you do anything! Serious personal injury may occur.

If noises occur that cannot be found by visual inspection, feel free to contact our service department for help.

CAUTION

If the lathe runs smoothly, try mounting a piece of turning stock. If a problem exists, stop the machine and review all the adjustments. Call for assistance, if needed.



Tool Rest

Adjust the tool rest as close to the workpiece as possible without actually coming in contact with the workpiece. Test by hand turning the workpiece before turning lathe on. Ensure that the lathe chisel is fully supported by the tool rest. Support the lathe chisel on the tool rest with one hand, while controlling the chisel with the other hand (**Figure 21**). For outboard turning, it may be desirable to use a free standing tool rest.

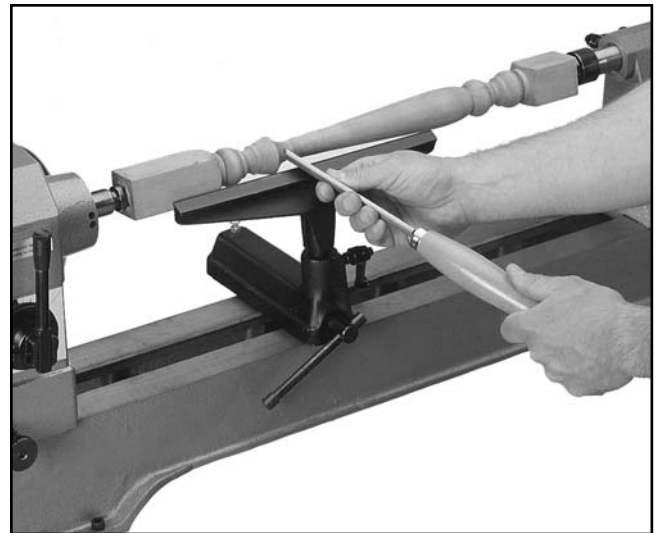

Figure 21.



Spindle Turning

Before a workpiece is mounted into the lathe, the points of the installed spur center and the live center must align perfectly with one another (Figure 22). View the alignment from above the lathe and from the side.

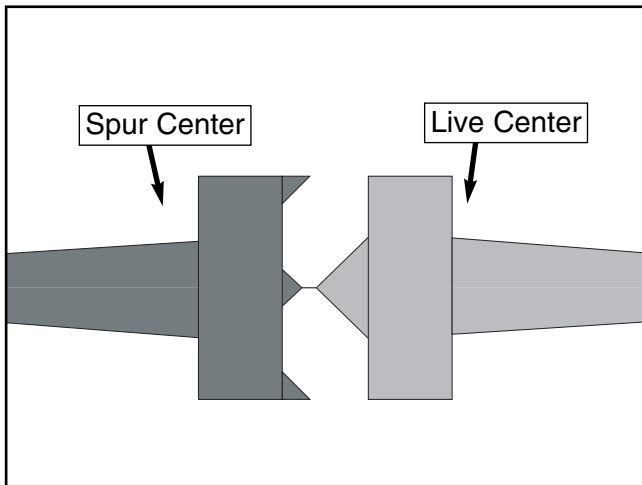

Figure 22.

To mount a workpiece between centers:

1. Locate the center point on both ends of the workpiece by carefully drawing diagonal lines from corner to corner. The point of intersection is the center of the work. Find the center of round wood stock by using a center finder instrument.
2. When turning stock with a diameter greater than 2", remove the corner length edges with a hand plane or similar operation. DO NOT attempt to "round" square stock in the lathe. Serious personal injury may occur.
3. Hold the spindle vertically and support it on a solid surface. Line up the spur center with the center of the workpiece. Drive the spur center into the stock about 1/4" using a dead blow hammer. Be careful not to split the workpiece. See Figure 23. Wood with splits along the grain may fly off during the operation. Note—*With dense wood, drill a hole at the center and score lines with a saw blade for the spur center.*

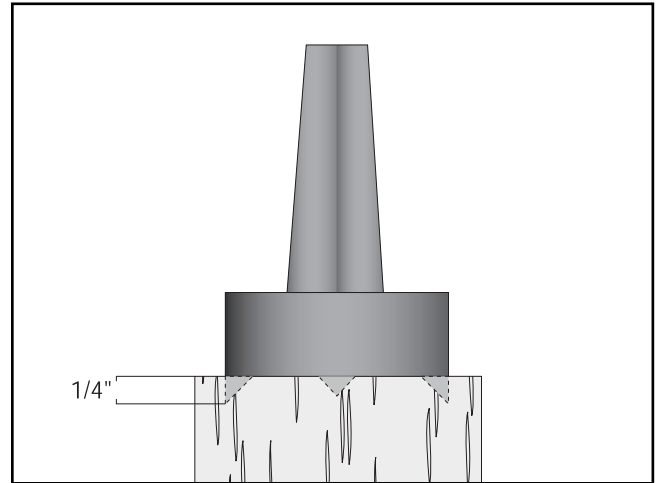

Figure 23.

4. Once the spur center is firmly attached to the workpiece, insert the spur center (with the attached workpiece) into the headstock spindle.
5. While supporting the workpiece, slide the tailstock close to the end of the workpiece and lock it into place.

!WARNING

Make sure the live center in the tailstock lines up with the spur center in the headstock before turning anything between centers. Failure to observe this step could result in the workpiece being thrown from the lathe. Serious personal injury may occur.

6. Line up the live center with the workpiece center. Turn the handwheel to press the point of the live center into the workpiece. Note—*With dense wood, drill a hole at the center and score lines with a saw blade for the live center.*

!WARNING

Do not press too firmly or the bearings will bind and overheat. Likewise, do not adjust too loosely or the workpiece will spin off the lathe. Use good judgement. Serious personal injury could result if care is not taken.

7. Lock the tailstock in place.



Outboard Turning

Outboard turning is usually done when stock diameter is greater than 12". For the size of this particular lathe and its minimum turning speed, we recommend a maximum diameter of 17" and a maximum thickness of 2".

Figure 24 depicts the lathe setup at 90° for turning a bowl using the tool rest extension supplied.

Figure 25 depicts the lathe setup at 180° for turning a bowl using a free standing tool rest (not supplied).

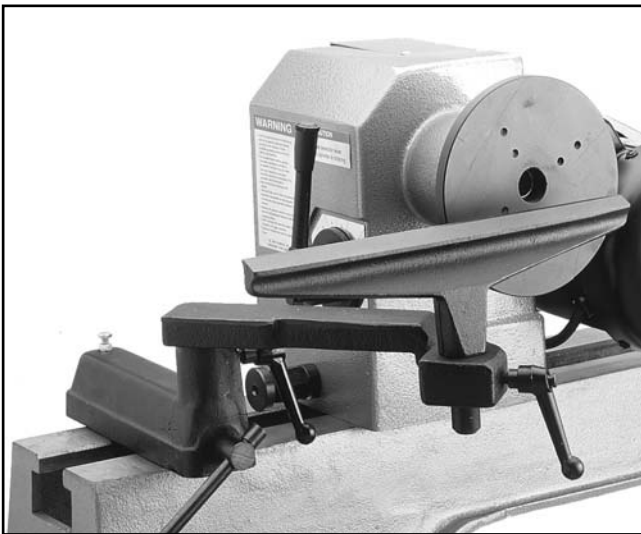

Figure 24. Headstock set at 90°.



Figure 25. Headstock set at 180°.



Indexing

The headstock spindle indexes every 15° by inserting the indexing pin into one of the holes in the headstock. Indexing is desirable when locking the workpiece in position such as when routing flutes. The spindle is drilled every 30° and the headstock housing has two holes that are drilled 15° apart. To index the spindle:

1. Insert the pin through the hole in the housing.
2. Rotate the spindle by hand until the pin drops into a hole in the spindle (**Figure 26**).

⚠ WARNING

Never start the lathe with the indexing pin inserted in the indexing hole. Serious personal injury may occur.



Figure 26. Spindle indexing.



SECTION 5: MAINTENANCE

General

WARNING

Before performing any type of inspection or maintenance work on this lathe, be sure that the power cord is unplugged and all moving parts have come to a complete stop. Serious personal injury may occur.

Make a habit of inspecting your lathe each time you use it. Check for the following conditions and repair or replace when necessary.

1. Loose mounting bolts.
2. Worn switch.
3. Worn or damaged cords and plugs.
4. Any other condition that could hamper the safe operation of this machine.



Bed

The bed and other non-painted surfaces on the Model G1067Z should be protected against rust and pitting. Wiping the lathe clean after every use ensures that moisture from wood dust isn't allowed to trap moisture against bare metal surfaces.



Lubrication

The G1067Z Lathe is equipped with a split pulley system which allows the speed of the lathe to be changed while its running. To assure the smooth operation of this pulley system, we recommend the main spindle and motor spindle be greased occasionally. To do this, remove the pulley cover, vacuum out any saw dust and apply grease to the spots indicated in **Figure 27**. Disposable acid brushes work best to get into these hard to reach places.

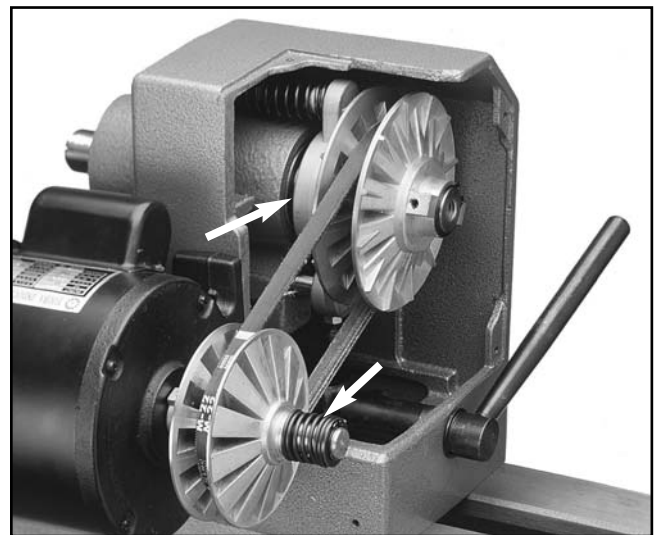

Figure 27.

Shielded and pre-lubricated ball bearings require no lubrication for the life of the bearings. In a continuous-use environment, expect the bearings to last for several years. With intermittent use, bearings can be expected to last much longer. All bearings are common sizes and can be easily obtained.



SECTION 6: CLOSURE

The following pages contain general machine data, parts diagram, parts list and Warranty/Return information for your Model G1067Z Lathe.

If you need parts or help in assembling your machine, or if you need operational information, we encourage you to call the appropriate regional Service Department. Our trained service technicians will be glad to help you.

If you have comments dealing specifically with this manual, please write to our Bellingham, Washington location using the address in the Introduction. The specifications, drawings, and photographs illustrated in this manual represent the Model G1067Z as supplied when the manual was prepared. However, due to Grizzly's policy of continuous improvement, changes may be made at any time with no obligation on the part of Grizzly. Whenever possible, though, we send manual updates to all owners of a particular tool or machine. Should you receive one, add the new information to this manual and keep it for reference.

We have included some important safety measures that are essential to this machine's operation. While most safety measures are generally universal, Grizzly reminds you that each workshop is different and safety rules should be considered *as they apply to your specific situation*.

We recommend you keep a copy of our current catalog for complete information regarding Grizzly's warranty and return policy. If you need additional technical information relating to this machine, or if you need general assistance or replacement parts, please contact the appropriate regional Service Department listed in the introduction.

Additional information sources are necessary to realize the full potential of this machine. Trade journals, woodworking magazines, and your local library are good places to start.

WARNING

Like all power tools, there is danger associated with the Model G1067Z Lathe. Use the tool with respect and caution to lessen the possibility of mechanical damage or operator injury. If normal safety precautions are overlooked or ignored, serious personal injury may occur.

WARNING

The Model G1067Z was specifically designed for turning operations. Do not modify and/or use this Lathe for any other purpose. If you are confused about any aspect of this machine, DO NOT use it until you have answered all your questions. Serious personal injury may occur.

NOTICE

Modifications or improper use of this tool will void the warranty.



Machine Data Sheet

Customer Service #: (570) 326-3806 • To Order Call: (800) 523-4777 • Fax #: (800) 438-5901

Model G1067Z Wood Lathe

Design TypeFloor Model

Overall Dimensions:

Including Stand45 $\frac{3}{4}$ " H x 20" W x 58 $\frac{3}{4}$ " L
Swing Over Bed.....14"
Swing Over Gap17"
Distance Between Centers40"
Shipping Weight.....190 lbs.
Weight in Place.....179 lbs.

Construction:

BedPrecision Ground Cast Iron
HeadstockCast Iron
StandPre-Formed Sheet Steel
Spindle.....Shielded & Lubricated-For-Life Ball Bearings

Specifications:

Spindle Size1" x 12 TPI RH
Bore Through Spindle0.406"
Tailstock Taper.....MT #2
Spindle Taper.....MT #2 Spur Center
Number / Range of Speeds6 / 500 to 2700 RPM

Motor:

TypeTEFC Capacitor Start Induction
Horsepower $\frac{1}{2}$ HP
Phase / CycleSingle Phase / 60 Hz
Voltage110V
Amps8
RPM1720
BearingsShielded & Lubricated-For-Life Ball Bearings
SwitchSafety Key Toggle Switch

Standard Features:

.....Swivel Head
.....6" Face Plate
.....Articulated Tool Rest Support

Specifications, while deemed accurate, are not guaranteed.

12/2003

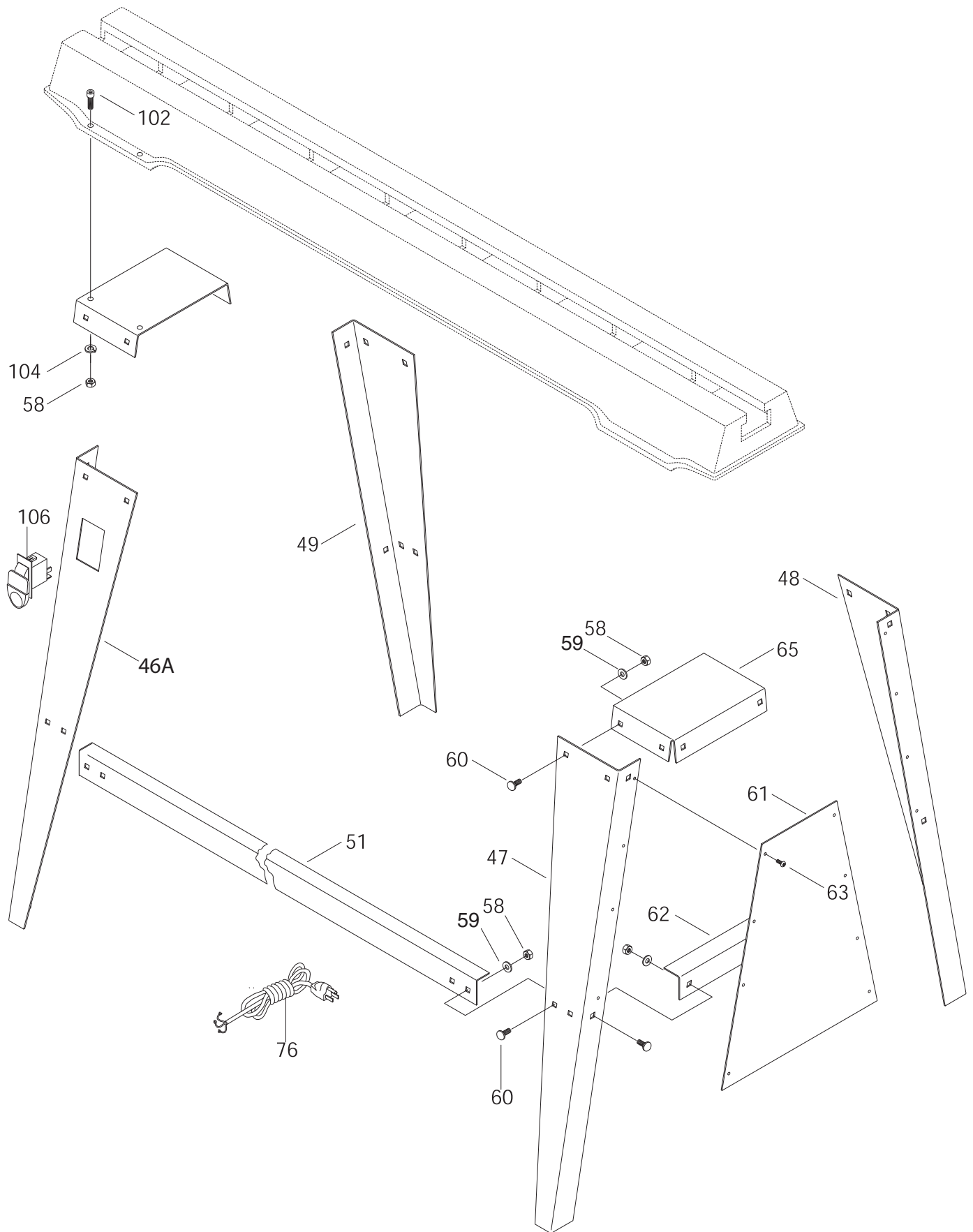

REF	PART #	DESCRIPTION
1	P1067Z001	BED
2	P1067Z002	HEADSTOCK
3	P6205	BEARING 6205
4	P1067Z004	INDEXING BLOCK
5	P1067Z005	MAIN SPINDLE
6	PFH08	FLAT HD SCR 10-24 X 1/2"
7	PK88M	KEY 4 X 4 X 74
8	P1067Z008	BRACKET
9	P6006	BEARING 6006
11	P1067Z011	LOCKING STUD
12	P1067Z012	SHIFTING ROD
13	P1067Z013	PINION SHAFT
14	P1067Z014	INDEXING PLATE
15	P1067Z015	DETENT PIN ASSEMBLY
16	P1067Z016	COLLAR
17	P1067Z017	SPEED CHANGE LEVER
18	PN05	HEX NUT 1/4"-20
19	P1067Z019	INDEXING PIN
20	P1067Z020	SPRING
21	P1067Z021	PULLEY COVER
22	P1495022	FACE PLATE
23	P1067Z023	MT#2 SPUR CENTER
24	P1067Z024	TAILSTOCK HOUSING
25	P1495025A	TAILSTOCK BARREL
26	P1495026	TAILSTOCK LEAD SCREW
27	PSS03	SET SCREW 1/4"-20 x 3/8"
28	P1495028	HAND WHEEL
29	PSS17	SET SCREW 5/16"-18 x 5/16"
30	P1495030	HANDLE
32	P1067Z032	CAM SLIDE BAR
33	P1067Z033	SPECIAL BOLT M20-2.5 X 22
34	P1495034	LOCK BLOCK
36	P1495036	LOCK HANDLE
37	P1067Z037	MT#2 LIVE CENTER
38	P1067Z038	LOCKING LEVER
39	PR58M	EXT RETAINING RING 24MM
40	P1067Z040	ECCENTRIC SHAFT
41	PR11M	EXT RETAINING RING 25MM
42	PSB06	CAP SCREW 1/4"-20 x 1"
43	PEC04M	E-CLIP 13MM
46A	P1067Z046A	LEG, LEFT FRONT V2.01.02
47	P1067Z047	LEG, RIGHT FRONT
48	P1067Z048	LEG, RIGHT REAR
49	P1067Z047	LEG, LEFT REAR
50	P1495050	TOOL REST BODY
51	P1067Z051	CROSS BRACE, LONG

REF	PART #	DESCRIPTION
52	P1495051	ECCENTRIC ROD W/052
53	PB31	HEX BOLT 1/4"-20 x 1"
54	P1067Z054	TOOL REST W/070
55	P1495031	LOCKING LEVER
58	PN02	HEX NUT 5/16"-18
59	PW07	FLAT WASHER 5/16"
60	PCB01	CARRIAGE BOLT 5/16"-18 x 5/8"
61	P1067Z061	END PANEL
62	P1067Z062	CROSS BRACE, SHORT
63	PS06	PHLP HD SCR 10-24 x 3/8"
64	P1067Z064	MOTOR 1/2 HP
64-1	P1067Z064-1	FAN COVER
64-2	P1067Z064-2	FAN
64-3	P1067Z064-3	WIRING COVER
64-4	PC200	S CAPACITOR 200M 125V
64-5	P1067Z064-5	CAPACITOR COVER
65	P1067Z065	TOP BRACE
66	PLABEL-7	GRIZZLY LOGO LABEL
67	PK89M	KEY 4 X 4 X 84
69	P1067Z069	SPEED CHART
70	P1067Z070	SPRING
71	P1067Z071	SPRING RETAINER
72	PR06M	EXT RETAINING RING 16MM
73	P1067Z073	CAUTION LABEL
74	PSS11	SET SCREW 1/4"-20 x 1/4"
75	PS06	PHLP HD SCR 10-24 x 3/8"
76	PWRCRD110L	POWER CORD
78	P1067Z078	SAFETY LABEL
79	P1067Z079	STOP BAR
80	PVM22	V-BELT M-22
81	P1067Z081	MACHINE ID LABEL
82	PSS02	SET SCREW 5/16"-18 x 3/8"
83	P1495083	SPECIAL BOLT M20-2.5 X 22
84	P1067Z084	HANDLE
85	P1067Z085	TOOL REST EXTENSION
86	PB03	HEX BOLT 5/16"-18 x 1"
87	PLW01	LOCK WASHER 5/16"
98	P1067Z098	KNOCK OUT BAR
99	P1067Z099	BOLT BAG
100	PR15M	EXT RETAINING RING 30M
101	P1067Z101	MOTOR PULLEY SET
102	PSB03	CAP SCREW 5/16"-18 x 1"
103	PLN12	LOCK NUT 3/4"-10
104	PLW01	LOCK WASHER 5/16"
105V2	P1067Z105V2	SPINDLE PULLEY SET
106	PSW07	GRIZZLY PADDLE SWITCH

Warranty & Returns

Grizzly Industrial, Inc. warrants every product it sells for a period of **1 year** to the original purchaser from the date of purchase. This warranty does not apply to defects due directly or indirectly to misuse, abuse, negligence, accidents, repairs or alterations or lack of maintenance. This is Grizzly's sole written warranty and any and all warranties that may be implied by law, including any merchantability or fitness, for any particular purpose, are hereby limited to the duration of this written warranty. We do not warrant or represent that the merchandise complies with the provisions of any law or acts unless the manufacturer so warrants. In no event shall Grizzly's liability under this warranty exceed the purchase price paid for the product and any legal actions brought against Grizzly shall be tried in the State of Washington, County of Whatcom.

We shall in no event be liable for death, injuries to persons or property or for incidental, contingent, special, or consequential damages arising from the use of our products.

To take advantage of this warranty, contact us by mail or phone and give us all the details. We will then issue you a "Return Number," which must be clearly posted on the outside as well as the inside of the carton. We will not accept any item back without this number. Proof of purchase must accompany the merchandise.

The manufacturers reserve the right to change specifications at any time because they constantly strive to achieve better quality equipment. We make every effort to ensure that our products meet high quality and durability standards and we hope you never need to use this warranty.

Please feel free to write or call us if you have any questions about the machine or the manual.

Thank you again for your business and continued support. We hope to serve you again soon.



WARRANTY CARD

Name _____
 Street _____
 City _____ State _____ Zip _____
 Phone Number _____ E-Mail _____ FAX _____
MODEL # _____ **Serial #** _____ **Order #** _____

The following information is given on a voluntary basis. It will be used for marketing purposes to help us develop better products and services. Of course, all information is strictly confidential.

1. How did you learn about us?

<input type="checkbox"/> Advertisement	<input type="checkbox"/> Friend
<input type="checkbox"/> Catalog	<input type="checkbox"/> Card Deck
<input type="checkbox"/> World Wide Web	
<input type="checkbox"/> Other _____	
2. Which of the following magazines do you subscribe to.

<input type="checkbox"/> American Woodworker	<input type="checkbox"/> Practical Homeowner
<input type="checkbox"/> Cabinetmaker	<input type="checkbox"/> Shop Notes
<input type="checkbox"/> Family Handyman	<input type="checkbox"/> Today's Homeowner
<input type="checkbox"/> Fine Homebuilding	<input type="checkbox"/> WOOD
<input type="checkbox"/> Fine Woodworking	<input type="checkbox"/> Wooden Boat
<input type="checkbox"/> Home Handyman	<input type="checkbox"/> Woodshop News
<input type="checkbox"/> Journal of Light Construction	<input type="checkbox"/> Woodsmith
<input type="checkbox"/> Old House Journal	<input type="checkbox"/> Woodwork
<input type="checkbox"/> Popular Mechanics	<input type="checkbox"/> Woodworker
<input type="checkbox"/> Popular Science	<input type="checkbox"/> Woodworker's Journal
<input type="checkbox"/> Popular Woodworking	<input type="checkbox"/> Workbench
<input type="checkbox"/> Other _____	
3. Which of the following woodworking/remodeling shows do you watch?

<input type="checkbox"/> Backyard America	<input type="checkbox"/> The New Yankee Workshop
<input type="checkbox"/> Home Time	<input type="checkbox"/> This Old House
<input type="checkbox"/> The American Woodworker	<input type="checkbox"/> Woodwright's Shop
<input type="checkbox"/> Other _____	
4. What is your annual household income?

<input type="checkbox"/> \$20,000-\$29,999	<input type="checkbox"/> \$60,000-\$69,999
<input type="checkbox"/> \$30,000-\$39,999	<input type="checkbox"/> \$70,000-\$79,999
<input type="checkbox"/> \$40,000-\$49,999	<input type="checkbox"/> \$80,000-\$89,999
<input type="checkbox"/> \$50,000-\$59,999	<input type="checkbox"/> \$90,000 +
5. What is your age group?

<input type="checkbox"/> 20-29	<input type="checkbox"/> 50-59
<input type="checkbox"/> 30-39	<input type="checkbox"/> 60-69
<input type="checkbox"/> 40-49	<input type="checkbox"/> 70 +
6. How long have you been a woodworker?

<input type="checkbox"/> 0 - 2 Years	<input type="checkbox"/> 8 - 20 Years
<input type="checkbox"/> 2 - 8 Years	<input type="checkbox"/> 20+ Years
7. How would you rank your woodworking skills?

<input type="checkbox"/> Simple	<input type="checkbox"/> Advanced
<input type="checkbox"/> Intermediate	<input type="checkbox"/> Master Craftsman
8. What stationary woodworking tools do you own? Check all that apply.

<input type="checkbox"/> Air Compressor	<input type="checkbox"/> Panel Saw
<input type="checkbox"/> Bandsaw	<input type="checkbox"/> Planer
<input type="checkbox"/> Drill Press	<input type="checkbox"/> Power Feeder
<input type="checkbox"/> Drum Sander	<input type="checkbox"/> Radial Arm Saw
<input type="checkbox"/> Dust Collector	<input type="checkbox"/> Shaper
<input type="checkbox"/> Horizontal Boring Machine	<input type="checkbox"/> Spindle Sander
<input type="checkbox"/> Jointer	<input type="checkbox"/> Table Saw
<input type="checkbox"/> Lathe	<input type="checkbox"/> Vacuum Veneer Press
<input type="checkbox"/> Mortiser	<input type="checkbox"/> Wide Belt Sander
<input type="checkbox"/> Other _____	
9. How many of your woodworking machines are Grizzly? _____
10. Which benchtop tools do you own? Check all that apply.

<input type="checkbox"/> 1" x 42" Belt Sander	<input type="checkbox"/> 6" - 8" Grinder
<input type="checkbox"/> 5" - 8" Drill Press	<input type="checkbox"/> Mini Lathe
<input type="checkbox"/> 8" Table Saw	<input type="checkbox"/> 10" - 12" Thickness Planer
<input type="checkbox"/> 8" - 10" Bandsaw	<input type="checkbox"/> Scroll Saw
<input type="checkbox"/> Disc/Belt Sander	<input type="checkbox"/> Spindle/Belt Sander
<input type="checkbox"/> Mini Jointer	
<input type="checkbox"/> Other _____	
11. How many of the machines checked above are Grizzly? _____
12. Which portable/hand held power tools do you own? Check all that apply.

<input type="checkbox"/> Belt Sander	<input type="checkbox"/> Orbital Sander
<input type="checkbox"/> Biscuit Joiner	<input type="checkbox"/> Palm Sander
<input type="checkbox"/> Circular Saw	<input type="checkbox"/> Portable Planer
<input type="checkbox"/> Detail Sander	<input type="checkbox"/> Saber Saw
<input type="checkbox"/> Drill/Driver	<input type="checkbox"/> Reciprocating Saw
<input type="checkbox"/> Miter Saw	<input type="checkbox"/> Router
<input type="checkbox"/> Other _____	
13. What machines/supplies would you like Grizzly Industrial to carry?

14. What new accessories would you like Grizzly Industrial to carry?

15. What other companies do you purchase your tools and supplies from?

16. Do you think your purchase represents good value?
 Yes No
17. Would you recommend Grizzly Industrial to a friend?
 Yes No
18. Would you allow us to use your name as a reference for Grizzly customers in your area? **Note: We never use names more than three times.**
 Yes No
19. Comments: _____

CUT ALONG DOTTED LINE

FOLD ALONG DOTTED LINE



Place
Stamp
Here



GRIZZLY INDUSTRIAL, INC.
P.O. BOX 2069
BELLINGHAM, WA 98227-2069



FOLD ALONG DOTTED LINE

Send a Grizzly Catalog to a friend:

Name _____
Street _____
City _____ State _____ Zip _____

TAPE ALONG EDGES--PLEASE DO NOT STAPLE

grizzly.com

TOOL WEBSITE

Buy Direct and Save with Grizzly® – Trusted, Proven and a Great Value!

*Visit Our Website Today And Discover Why
Grizzly® Is The Industry Leader!*

- SECURE ORDERING
- ORDERS SHIPPED WITHIN 24 HOURS
- E-MAIL RESPONSE WITHIN ONE HOUR

-OR-

Call Today For A **FREE**
Full Color Catalog

1-800-523-4777

