

G0506

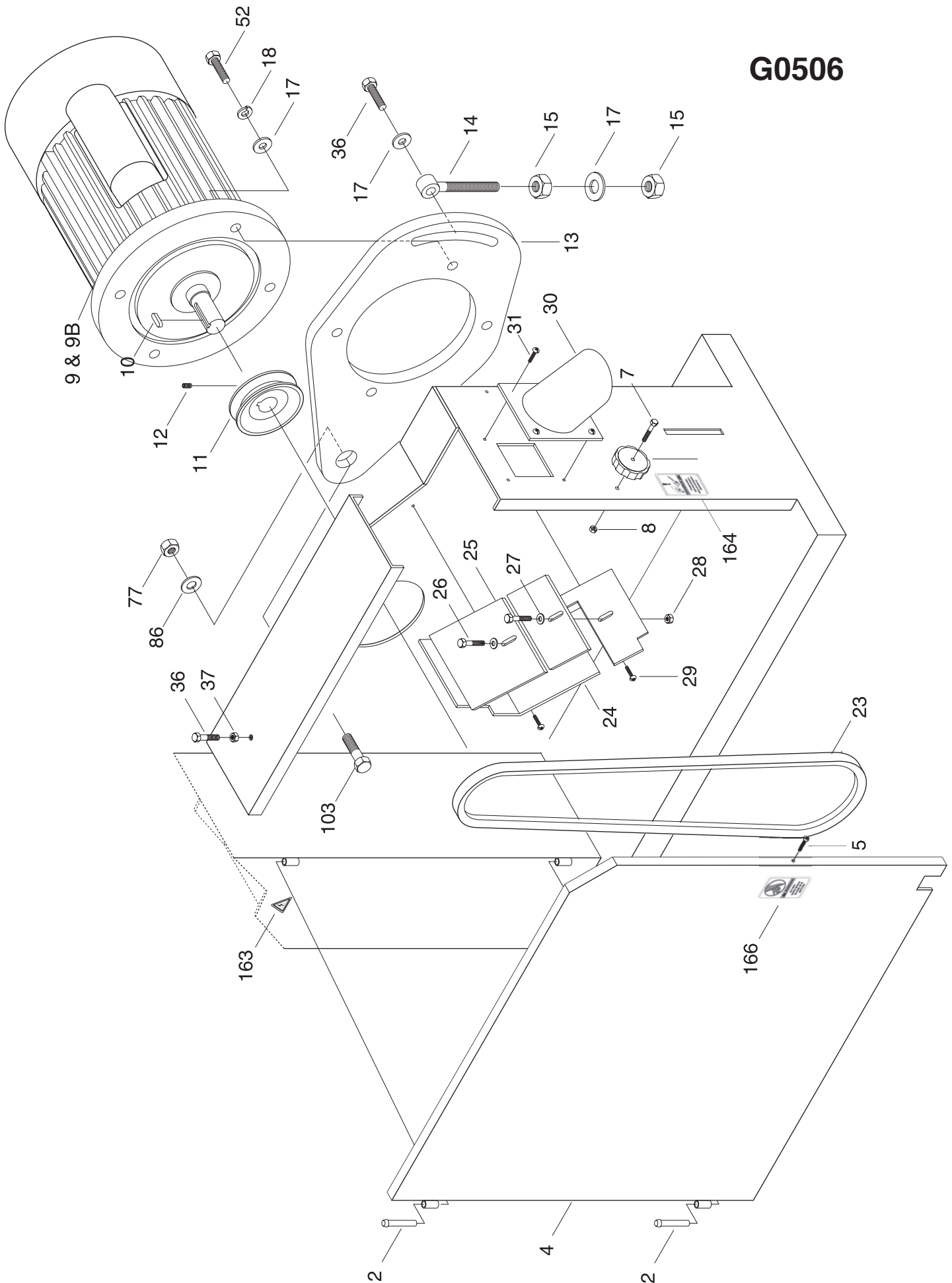

G0506

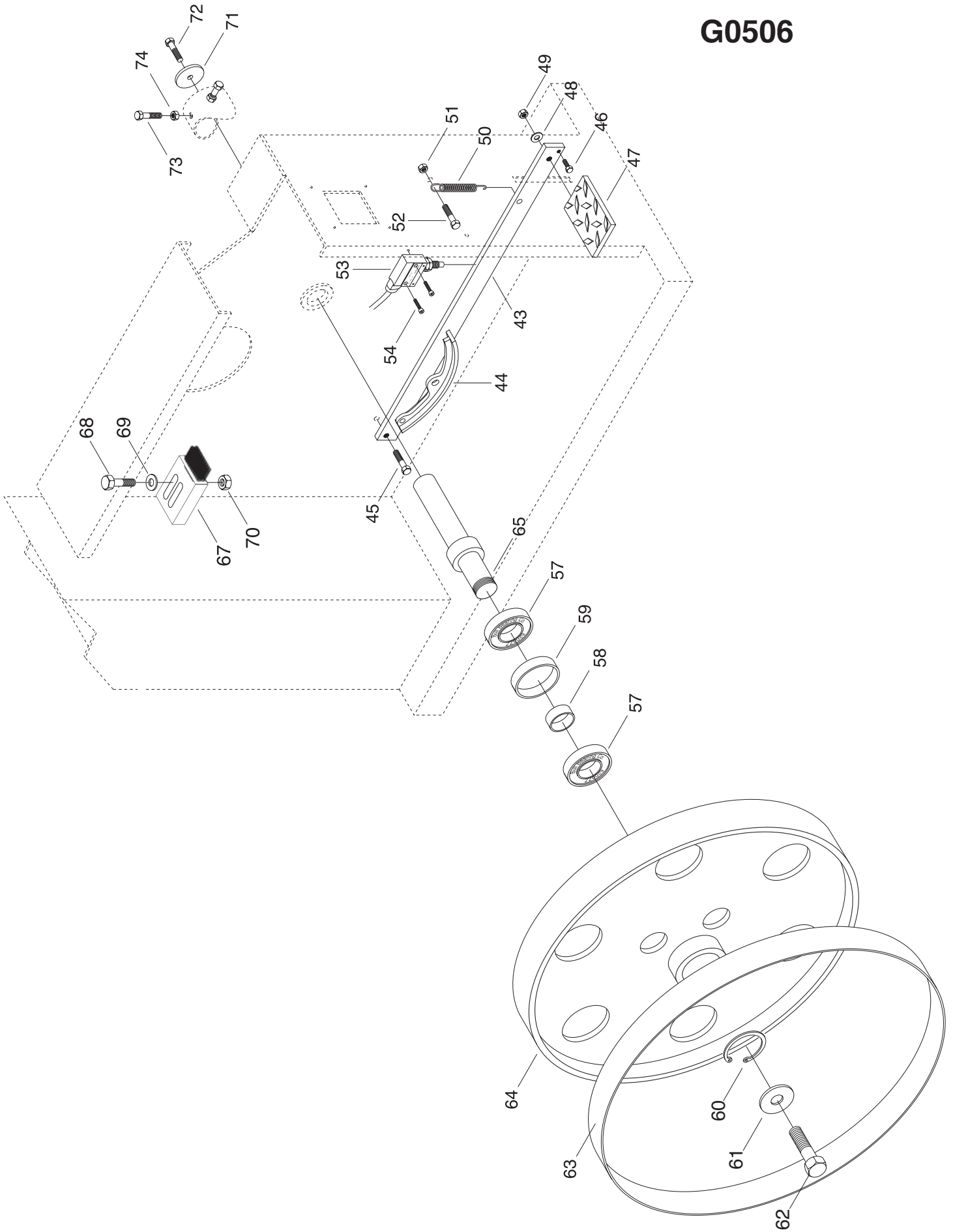

G0506

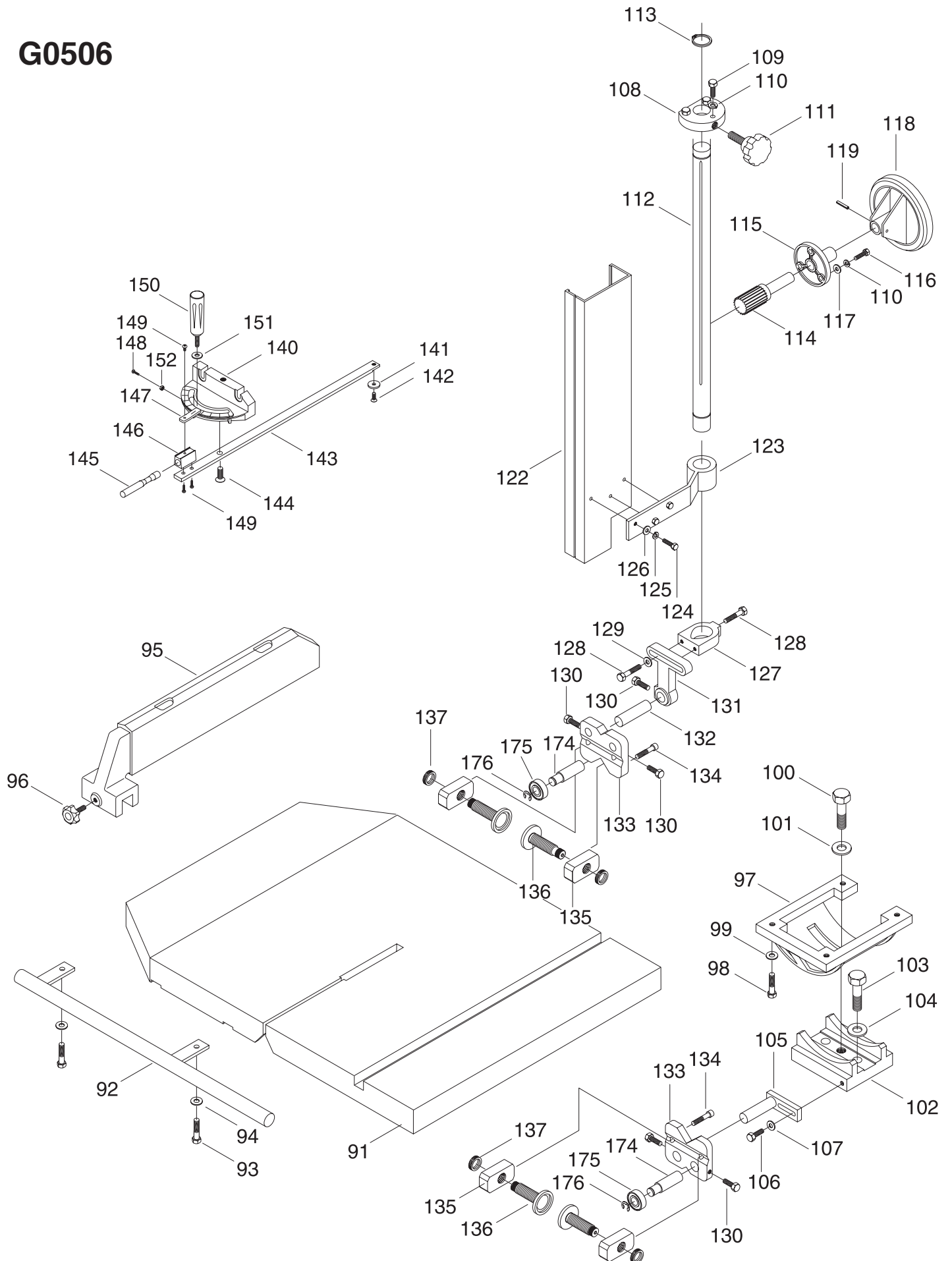

G0506

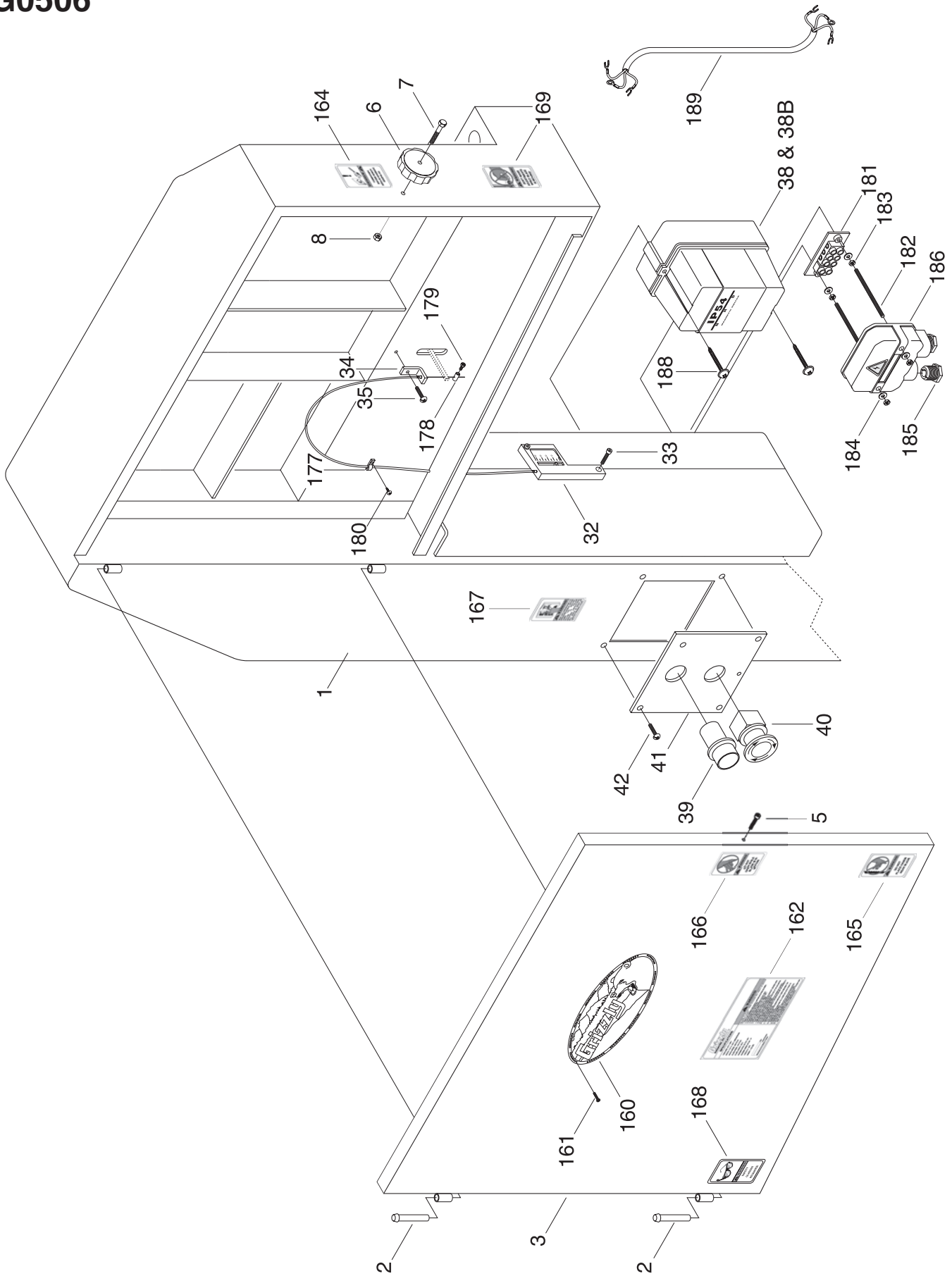

G0506

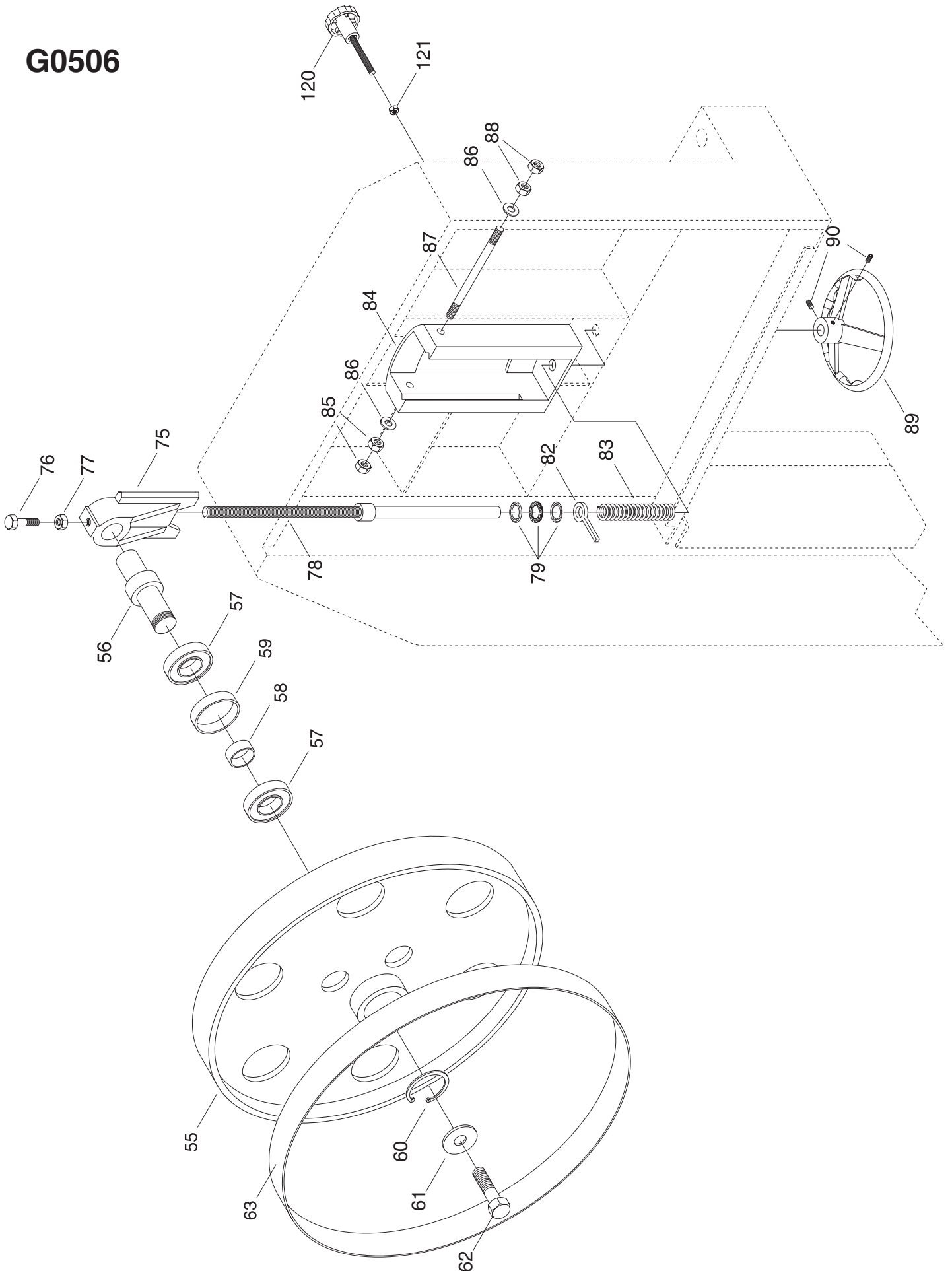

G0506

REF	PART #	DESCRIPTION
001	P0506001	FRAME
002	P0506002	HINGE
003	P0506003	UPPER WHEEL GUARD
004	P0506004	LOWER WHEEL GUARD
005	PSB17	CAP SCREW 1/4"-20 X 3/8"
006	P0506006	WHEEL GUARD LOCK KNOB
007	PSB05	CAP SCREW 1/4"-20 X 3/4"
008	PN05	HEX NUT 1/4"
009	P0506009	1-PH 2 HP MOTOR
09-1	P0506009-1	CAPACITOR 400MFD-125V
010	PK43M	KEY 8 X 8 X 45
011	P0506011	MOTOR PULLEY
012	PSS08	SETSCREW 5/16"-18 X 1/2"
013	P0506013	MOTOR FLANGE
014	P0506014	ADJUSTING SCREW 3/8"-16
015	PN08	HEX NUT 3/8"-16
017	PW02	FLAT WASHER 3/8"
018	PLW04	LOCK WASHER 3/8"
023	PVA37	V-BELT A37
024	P0506024	DUST BOARD
025	P0506025	WOOD BOARD
026	PB03	HEX BOLT 5/16"-18 X 1"
027	PW07	FLAT WASHER 5/16"
028	PN02	HEX NUT 5/16"
029	PS06	HEX BOLT 10-24 X 3/8"
030	P0506030	CHIP CHUTE
031	PS06	PHLP HD SCR 10-24 X 3/8"
032	P0506032	BLADE TENSION INDICATOR
033	PSB04	CAP SCREW 1/4"-20 X 1/2"
034	P0506034	WIRE BRACKET
035	PS06	PHLP HD SCR 10-24 X 3/8"
036	PB58	HEX BOLT 3/8"-16 X 2"
037	PN08	HEX NUT 3/8"-16
038	P0506038	1-PH MAG SWITCH
38-1	P0506038-1	CONTACTOR/THERMAL OVRLD
039	P0506039	ON SWITCH (GREEN)
040	P0506040	OFF SWITCH (RED)
041	P0506041	POWER CONTROL PANEL
042	PS06	PHLP HD SCR 10-24 X 3/8"
043	P0506043	CONNECTION PLATE
044	P0506044	BRAKE LINING
045	PB18	HEX BOLT 3/8"-16 X 1"
046	PB19	HEX BOLT 1/4"-20 X 1/2"
047	P0506047	FOOT BRAKE PEDAL
048	PLW04	LOCK WASHER 3/8"
049	PN08	HEX NUT 3/8"-16
050	P0506050	SPRING
051	PN08	HEX NUT 3/8"-16

REF	PART #	DESCRIPTION
052	PB21	HEX BOLT 3/8"-16 X 3/4"
053	P0506053	STOP SWITCH
054	PSB21M	CAP SCREW M4-.7 X 30
055	P0506055	UPPER WHEEL
056	P0506056	UPPER WHEEL SHAFT
057	P6205	BEARING 6205Z
058	P0506058	IN BUSHING
059	P0506059	OUT BUSHING
060	P0506060	INT SNAP RING 52MM
061	PW021	FLAT WASHER 3/8"
062	PB03	HEX BOLT 3/8"-16 X 1"
063	P0506063	RUBBER CROWN
064	P0506064	LOWER WHEEL
065	P0506065	LOWER WHEEL SHAFT
066	P0506066	BRUSH BRACKET
067	P0506067	BRUSH
068	PB03	HEX BOLT 5/16"-18 X 1"
069	PW07	FLAT WASHER 5/16"
070	PN02	HEX NUT 5/16"-18
071	P0506071	SPECIAL WASHER 3/8"~2"
072	PB24	HEX BOLT 3/8"-16 X 1 1/4"
073	PB24	HEX BOLT 3/8"-16 X 1 1/4"
074	PN08	HEX NUT 3/8"-16
075	P0506075	ARBOR BRACKET
076	PB24	HEX BOLT 3/8"-16 X 1 1/4"
077	PN08	HEX NUT 3/8"-16
078	P0506078	BLADE TENSION SHAFT
079	P51104	THRUST BEARING 51104
082	P0506082	INDICATOR WIRE PULLER
083	P0506083	SPRING
084	P0506084	BRACKET HOLDER
085	PN08	HEX NUT 3/8"-16
086	PW02	FLAT WASHER 3/8"
087	P0506087	BRACKET SHAFT
088	PN08	HEX NUT 3/8"-16
089	P0506089	TENSION HANDWHEEL
090	PSS08	SETSCREW 5/16"-18 X 1/2"
091	P0506091	TABLE
092	P0506092	FENCE RAIL
093	PB18	HEX BOLT 3/8"-16 X 1"
094	PW02	FLAT WASHER 3/8"
095	P0506095	FENCE
096	P0506096	FENCE KNOB 3/8"-16 X 1 1/4"
097	P0506097	TRUNNION
098	PSB19	CAP SCREW 3/8"-16 X 1 1/4"
099	PLW04	LOCK WASHER 3/8"
100	P0506100	HEX BOLT 1/2"-12 X 1 3/4"
101	PW01	FLAT WASHER 1/2"

G0506

REF	PART #	DESCRIPTION
102	P0506102	TRUNNION BRACKET
103	P0506100	HEX BOLT 1/2"-12 X 1 3/4"
104	PLW07	LOCK WASHER 1/2"
105	P0506105	BLADE GUIDE FORK
106	PB07	HEX BOLT 5/16"-18 X 3/4"
107	PW02	FLAT WASHER 3/8"
108	P0506108	SHAFT CAP
109	PB03	HEX BOLT 5/16"-18 X 1"
110	PLW01	LOCK WASHER 5/16"
111	P0506111	LOCK KNOB 3/8"-16 X 2 1/4"
112	P0506112	GUIDE SHAFT
113	P0506113	C-CLIP
114	P0506114	ELEVATION GEAR SHAFT
115	P0506115	GEAR SHAFT BASE
116	PB03	HEX BOLT 5/16"-18 X 1"
117	PLW01	LOCK WASHER 5/16"
118	P0506118	HANDWHEEL
119	P0506119	SPRING KEY M4
120	P0506120	TRACK KNOB 3/8"-16 X 2 1/2"
121	PN08	HEX NUT 3/8"-16
122	P0506122	BLADE GUIDE GUARD
123	P0506123	BLADE GUARD BRACKET
124	PB19	HEX BOLT 1/4"-20 X 1 1/2"
125	PLW02	LOCK WASHER 1/4"
126	PW06	FLAT WASHER 1/4"
127	P0506127	BLADE GUIDE HOLDER
128	PB03	HEX BOLT 5/16"-18 X 1"
129	PW07	FLAT WASHER 5/16"
130	PB07	HEX BOLT 5/16"-18 X 3/4"
131	P0506131	ADJUSTMENT BRACKET
132	P0506132	BRACKET ARBOR
133	P0506133	BLADE GUIDE BASE
134	PSB07	CAP SCREW 5/16"-18 X 3/4"
135	P0506135	GUIDE WHEEL BRACKET
136	P0506136	GUIDE WHEEL
137	P0506137	GUIDE WHEEL NUT
140A	P0506140A	COMPLETE MITER GAUGE
140	P0506140	MITER GAUGE BODY

REF	PART #	DESCRIPTION
141	P0506141	T-SLOT WASHER
142	PFH09	FLAT HD SCR 1/4"-20 X 5/16"
143	P0506142	MITER BAR
144	P0506144	SPECIAL BOLT 1/4"-20 X 7/16"
145	P0506145	STOP PIN
146	P0506146	BLOCK
147	P0506147	INDICATOR
148	PS29	PHLP HD SCR 6-32 X 5/8"
149	PS06	PHLP HD SCR 10-24 X 3/8"
150	P0506150	HANDLE 5/16"-18 X 1 1/2"
151	PW07	FLAT WASHER 5/16"
152	PN12	HEX NUT 6-32
160	G8589	LARGE GRIZZLY LOGO
161	P05060161	SELF TAP SCR #5 X 3/8"
162	P05060162	G0506 ID LABEL
163	PLABEL-14	ELECTRICITY LABEL
164	PLABEL-18	UNPLUG BANDSAW LABEL
165	PLABEL-19	HANDS/BLADE LABEL
166	PLABEL-20	DON'T OPEN LABEL
167	PLABEL-12	READ MANUAL LABEL
168	PLABEL-11	SAFETY GLASSES LABEL
169	PLABEL-20	MOVING/ADJUST LABEL
174	P0506174	THRUST BEARING SHAFT
175	P6202RS	BALL BEARING 6202
176	PEC05M	E-CLIP 15MM
177	P0506177	CABLE CLIP
178	P0506178	CABLE NUT 6-32
179	PS37	PHLP HD SCR 6-32 X 5/16"
180	PS06	PHLP HD SCR 10-24 X 3/8"
181	P0506181	TERMINAL BLOCK
182	P0506182	STUD 10-24 X 2 1/2"
183	PN07	HEX NUT 10-24
184	PW03	FLAT WASHER 10-24
185	PSW10	STRAIN RELIEF 3/4"
186	P0506186	COVER
188	PHTEK5	SELF TAP SCR 10-24 X 2 1/4"
189	P0506189	POWER CORD



MACHINE DATA SHEET

Customer Service #: (570) 546-9663 • To Order Call: (800) 523-4777 • Fax #: (800) 438-5901

MODEL G0507 & G0511 20" SUPER HEAVY-DUTY BANDSAWS

Design TypeFloor Model

Overall Dimensions:

Table Size27" x 20½"
 Overall Height76"
 Height From Floor to Table36¼"
 Width37"
 Depth Including Fence29½"
 Shipping Weight748 lbs
 Machine Weight625 lbs
 Crate Size80¼"L x 27⅞"W x 39⅝"H
 Footprint30½" x 15½"

Capacities:

Throat Capacity (Left of Blade)19"
 Cutting Height Capacity11½"
 Table Tilt45°R
 Blade Size Range¾"~1"
 Standard Blade Length160⅜"-162⅝"
 Blade Speed.....4510 FPM

Construction:

TablePrecision Ground Cast Iron
 WheelsFully Balanced Cast Iron w/Polyurethane Tires
 Rip FencePrecision Ground Cast Iron
 Wheel Covers.....Pre-Formed Steel
 Guides.....Sturdy Roller Disc Blade Guides

Motor:

Type (G0507)TEFC Capacitor-Start Induction
 Horsepower.....3 HP
 Phase / VoltageSingle-Phase / 220V
 Amps23A
 Type (G0511).....TEFC Induction
 Horsepower.....5 HP
 Phase / VoltageThree-Phase / 220V/440V
 Amps13A/6.5
 Cycle / RPM.....60 Hertz / 3450 RPM
 SwitchMagnetic w/Thermal Overload Protector
 BearingsShielded & Lubricated Ball Bearings

Features:

.....4" Dust Hood
Foot Brake
Blade Tensioning Scale
Miter Gauge
Rack & Pinion Upper Guide Adjustment
Hinged Wheel Covers

Specifications, while deemed accurate, are not guaranteed.

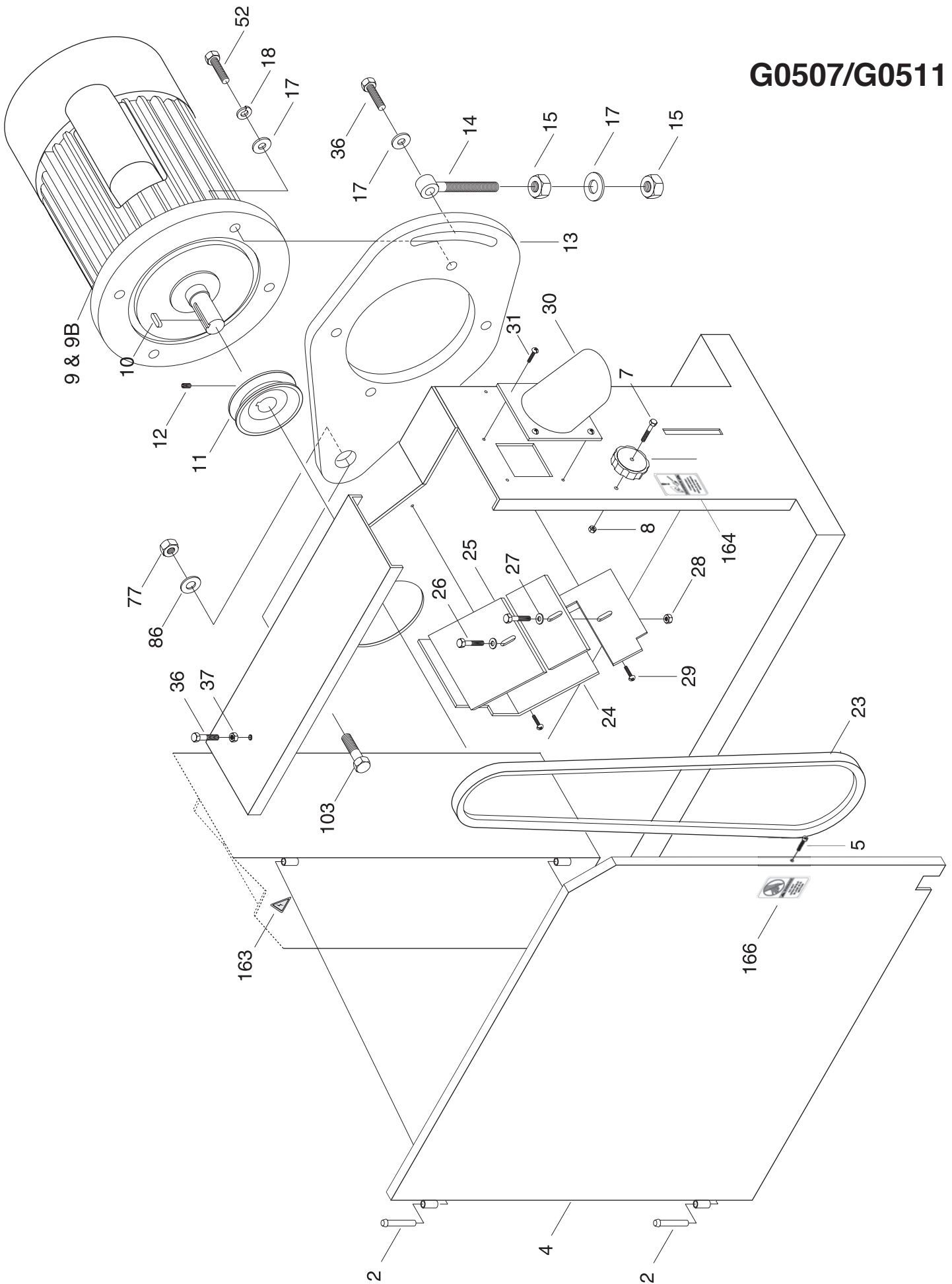

G0507/G0511

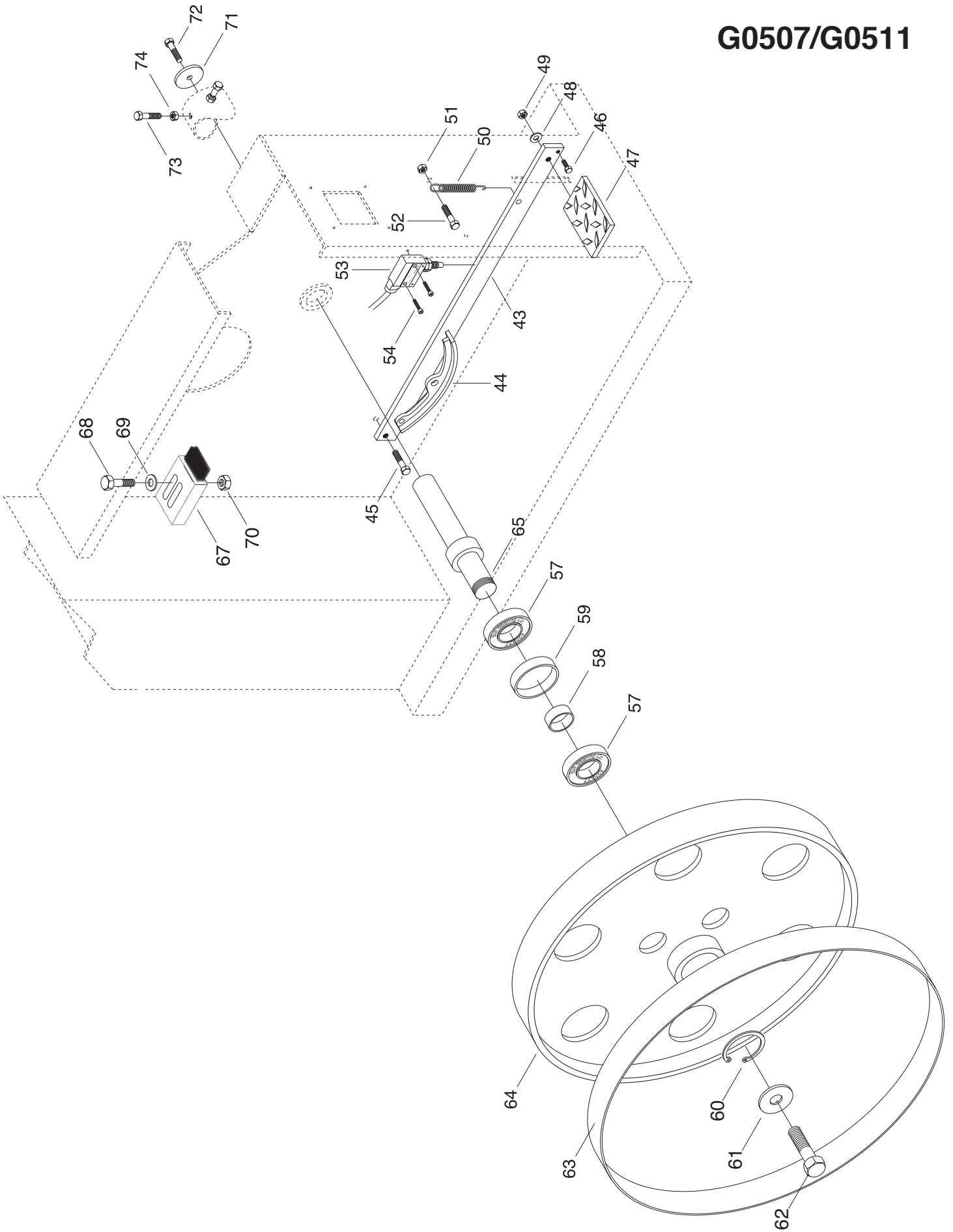

G0507/G0511

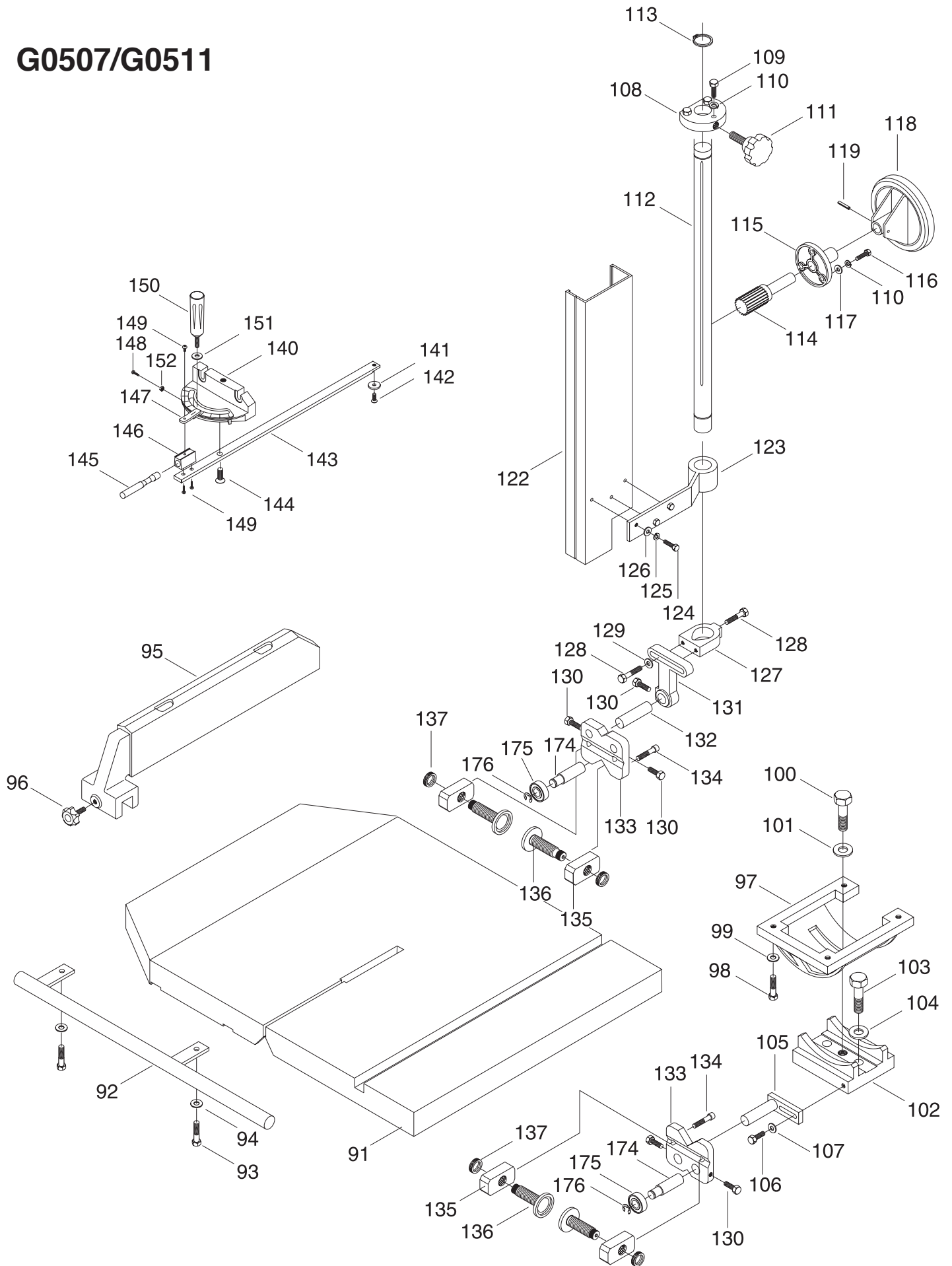

G0507/G0511

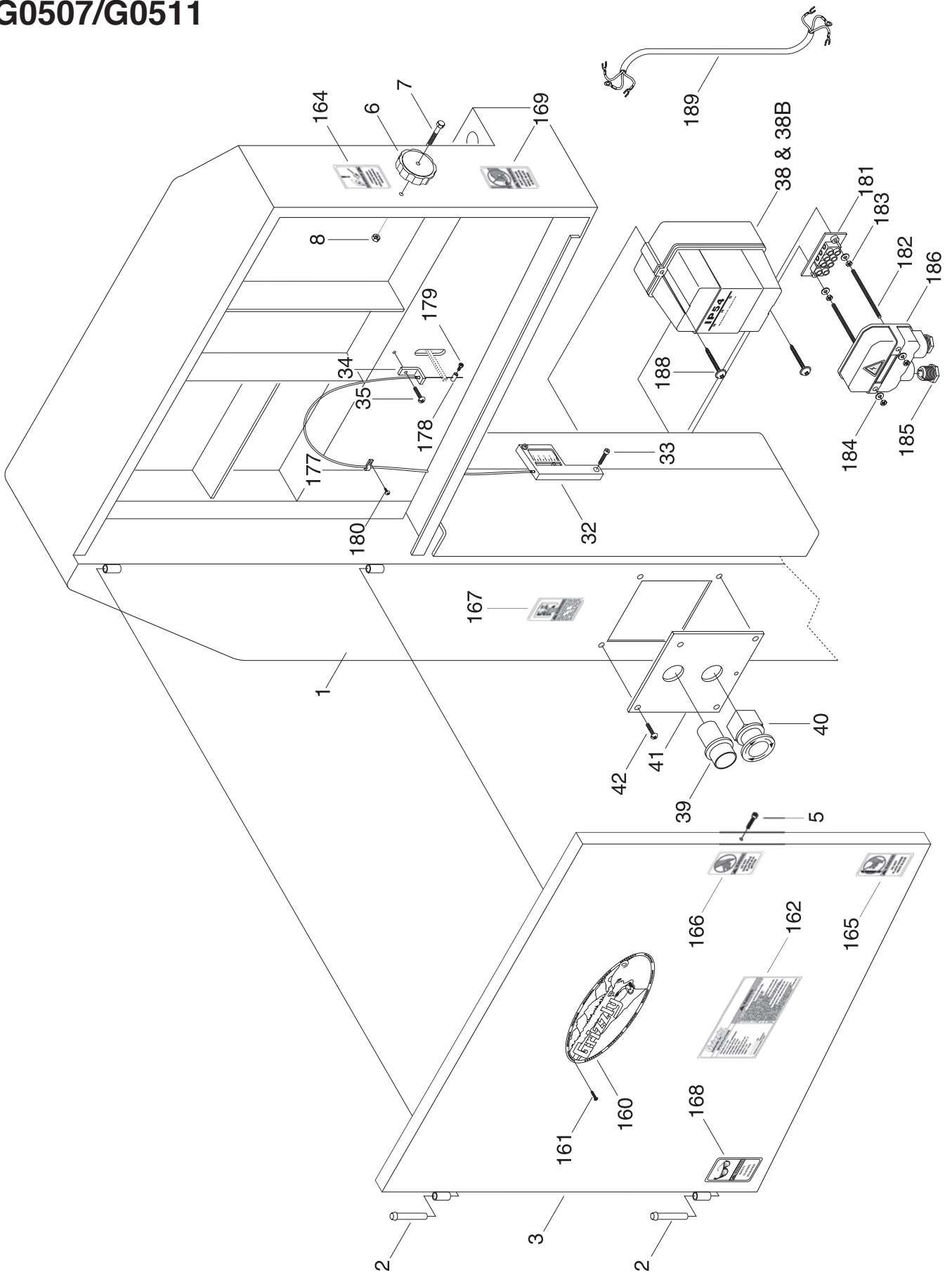

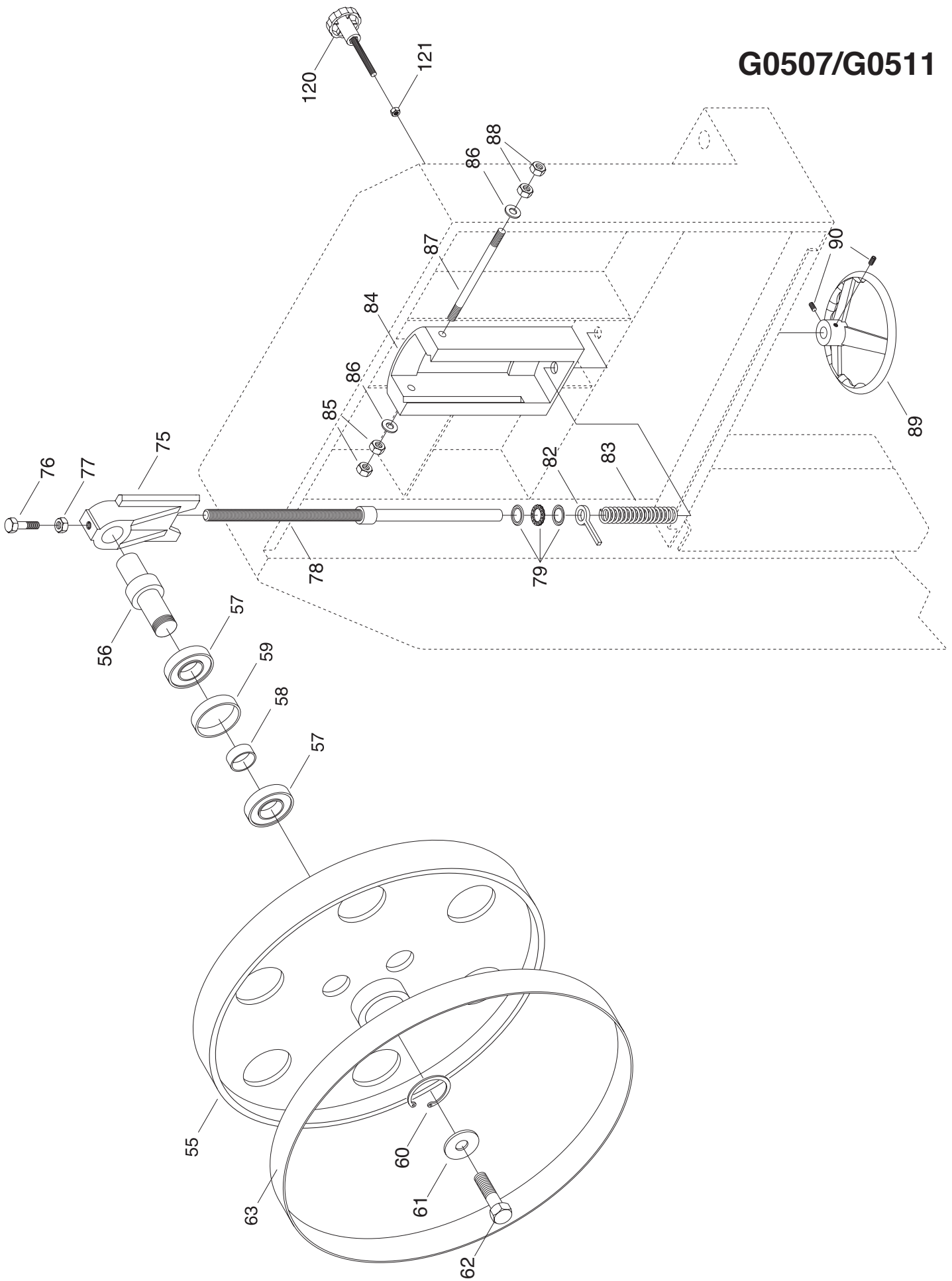

G0507/G0511

REF	PART #	DESCRIPTION
001	P0507001	FRAME
002	P0507002	HINGE
003	P0507003	UPPER WHEEL GUARD
004	P0507004	LOWER WHEEL GUARD
005	PSB17	CAP SCREW 1/4"-20 X 3/8"
006	P0507006	WHEEL GUARD LOCK KNOB
007	PSB05	CAP SCREW 1/4"-20 X 3/4"
008	PN05	HEX NUT 1/4"
009	P0507009	1-PH 3 HP MOTOR
009B	P0511009	3-PH 5 HP MOTOR
09-1	P0507009-1	CAPACITOR 400MFD-250V
010	PK43M	KEY 8 X 8 X 45
011	P0507011	MOTOR PULLEY
012	PSS08	SETSCREW 5/16"-18 X 1/2"
013	P0507013	MOTOR FLANGE
014	P0507014	ADJUSTING SCREW 3/8"-16
015	PN08	HEX NUT 3/8"-16
017	PW02	FLAT WASHER 3/8"
018	PLW04	LOCK WASHER 3/8"
023	PVA46	V-BELT A46
024	P0507024	DUST BOARD
025	P0507025	WOOD BOARD
026	PB03	HEX BOLT 5/16"-18 X 1"
027	PW07	FLAT WASHER 5/16"
028	PN02	HEX NUT 5/16"
029	PS06	HEX BOLT 10-24 X 3/8"
030	P0507030	CHIP CHUTE
031	PS06	PHLP HD SCR 10-24 X 3/8"
032	P0507032	BLADE TENSION INDICATOR
033	PSB04	CAP SCREW 1/4"-20 X 1/2"
034	P0507034	WIRE BRACKET
035	PS06	PHLP HD SCR 10-24 X 3/8"
036	PB58	HEX BOLT 3/8"-16 X 2"
037	PN08	HEX NUT 3/8"-16
038	G4573	1-PH MAG SWITCH (G0507)
38-1	P0507038-1	CONTACTOR/THERMAL OVRLD
038B	G4674	3-PH MAG SWITCH (G0511)
38B-1	P0511038B-1	CONTACTOR/THERMAL OVRLD
039	P0507039	ON SWITCH (GREEN)
040	P0507040	OFF SWITCH (RED)
041	P0507041	POWER CONTROL PANEL
042	PS06	PHLP HD SCR 10-24 X 3/8"
043	P0507043	CONNECTION PLATE
044	P0507044	BRAKE LINING
045	PB18	HEX BOLT 3/8"-16 X 1"
046	PB19	HEX BOLT 1/4"-20 X 1/2"
047	P0507047	FOOT BRAKE PEDAL
048	PLW04	LOCK WASHER 3/8"

REF	PART #	DESCRIPTION
049	PN08	HEX NUT 3/8"-16
050	P0507050	SPRING
051	PN08	HEX NUT 3/8"-16
052	PB21	HEX BOLT 3/8"-16 X 3/4"
053	P0507053	STOP SWITCH
054	PSB21M	CAP SCREW M4-.7 X 30
055	P0507055	UPPER WHEEL
056	P0507056	UPPER WHEEL SHAFT
057	P6205	BEARING 6206Z
058	P0507058	IN BUSHING
059	P0507059	OUT BUSHING
060	P0507060	INT SNAP RING 62
061	P0507061	FLAT WASHER 3/8"
062	PB03	HEX BOLT 3/8"-16 X 1"
063	P0507063	RUBBER CROWN
064	P0507064	LOWER WHEEL
065	P0507065	LOWER WHEEL SHAFT
066	P0507066	BRUSH BRACKET
067	P0507067	BRUSH
068	PB03	HEX BOLT 5/16"-18 X 1"
069	PW07	FLAT WASHER 5/16"
070	PN02	HEX NUT 5/16"-18
071	P0507071	SPECIAL WASHER 3/8"~2"
072	PB24	HEX BOLT 3/8"-16 X 1 1/4"
073	PB24	HEX BOLT 3/8"-16 X 1 1/4"
074	PN08	HEX NUT 3/8"-16
075	P0507075	ARBOR BRACKET
076	PB42	HEX BOLT 1/2"-12 X 2"
077	PN06	HEX NUT 1/2"-12
078	P0507078	BLADE TENSION SHAFT
079	P51104	THRUST BEARING 51104
082	P0507082	INDICATOR WIRE PULLER
083	P0507083	SPRING
084	P0507084	BRACKET HOLDER
085	PN06	HEX NUT 1/2"-12
086	PW01	FLAT WASHER 1/2"
087	P0507087	BRACKET SHAFT
088	PN06	HEX NUT 1/2"-12
089	P0507089	TENSION HANDWHEEL
090	PSS08	SETSCREW 5/16"-18 X 1/2"
091	P0507091	TABLE
092	P0507092	FENCE RAIL
093	PB18	HEX BOLT 3/8"-16 X 1"
094	PW02	FLAT WASHER 3/8"
095	P0507095	FENCE
096	P0507096	FENCE KNOB 3/8"-16 X 1 1/4"
097	P0507097	TRUNNION
098	PSB19	CAP SCREW 3/8"-16 X 1 1/4"

G0507/G0511

REF	PART #	DESCRIPTION
099	PLW04	LOCK WASHER 3/8"
100	P0507100	HEX BOLT 5/8"-11 X 2"
101	PW14	FLAT WASHER 5/8"
102	P0507102	TRUNNION BRACKET
103	P0506100	HEX BOLT 1/2"-12 X 1 3/4"
104	PLW07	LOCK WASHER 1/2"
105	P0507105	BLADE GUIDE FORK
106	PB07	HEX BOLT 5/16"-18 X 3/4"
107	PW02	FLAT WASHER 3/8"
108	P0507108	SHAFT CUP
109	PB03	HEX BOLT 5/16"-18 X 1"
110	PLW01	LOCK WASHER 5/16"
111	P0507111	LOCK KNOB 3/8"-16 X 2 1/4"
112	P0507112	GUIDE SHAFT
113	P0507113	C-CLIP
114	P0507114	ELEVATION GEAR SHAFT
115	P0507115	GEAR SHAFT BASE
116	PB03	HEX BOLT 5/16"-18 X 1"
117	PLW01	LOCK WASHER 5/16"
118	P0507118	HANDWHEEL
119	P0507119	SPRING KEY M4
120	P0507120	TRACK KNOB 3/8"-16 X 2 1/2"
121	PN08	HEX NUT 3/8"-16
122	P0507122	BLADE GUIDE GUARD
123	P0507123	BLADE GUARD BRACKET
124	PB19	HEX BOLT 1/4"-20 X 1/2"
125	PLW02	LOCK WASHER 1/4"
126	PW06	FLAT WASHER 1/4"
127	P0507127	BLADE GUIDE HOLDER
128	PB03	HEX BOLT 5/16"-18 X 1"
129	PW07	FLAT WASHER 5/16"
130	PB07	HEX BOLT 5/16"-18 X 3/4"
131	P0507131	ADJUSTMENT BRACKET
132	P0507132	BRACKET ARBOR
133	P0507133	BLADE GUIDE BASE
134	PSB07	CAP SCREW 5/16"-18 X 3/4"
135	P0507135	GUIDE WHEEL BRACKET
136	P0507136	GUIDE WHEEL
137	P0507137	GUIDE WHEEL NUT

REF	PART #	DESCRIPTION
140A	P0507140A	COMPLETE MITER GAUGE
140	P0507140	MITER GAUGE BODY
141	P0507141	T-SLOT WASHER
142	PFH09	FLAT HD SCR 1/4"-20 X 5/16"
143	P0507143	MITER BAR
144	P0507144	SPECIAL BOLT 1/4"-20 X 7/16"
145	P0507145	STOP PIN
146	P0507146	BLOCK
147	P0507147	INDICATOR
148	PS29	PHLP HD SCR 6-32 X 5/8"
149	PS06	PHLP HD SCR 10-24 X 3/8"
150	P0507150	HANDLE 5/16"-18 X 1 1/2"
151	PW07	FLAT WASHER 5/16"
152	PN12	HEX NUT 6-32
160	G8589	LARGE GRIZZLY LOGO
161	P05070161	SELF TAP SCR #5 X 3/8"
162	P05070162	G0507 ID LABEL
163	PLABEL-14	ELECTRICITY LABEL
164	PLABEL-18	UNPLUG BANDSAW LABEL
165	PLABEL-19	HANDS/BLADE LABEL
166	PLABEL-20	DON'T OPEN LABEL
167	PLABEL-12	READ MANUAL LABEL
168	PLABEL-11	SAFETY GLASSES LABEL
169	PLABEL-21	MOVING/ADJUST LABEL
174	P0507174	THRUST BEARING SHAFT
175	P6202RS	BALL BEARING 6202
176	PR05M	EXT RETAINING RING 15MM
177	P0507177	CABLE CLIP
178	P0507178	CABLE NUT 6-32
179	PS37	PHLP HD SCR 6-32 X 5/16"
180	PS06	PHLP HD SCR 10-24 X 3/8"
181	P0507181	TERMINAL BLOCK
182	P0507182	STUD 10-24 X 2 1/2"
183	PN07	HEX NUT 10-24
184	PW03	FLAT WASHER 10-24
185	P0507185	STRAIN RELIEF 3/4"
186	P0507186	COVER
188	PHTEK5	SELF TAP SCR 10-24 X 2 1/4"
189	P0507189	POWER CORD

Parts for the G0511 are identical to the G0507 except those with the prefix of P0511.