

SECTION 9: PARTS

G0513 & G0513ANV Main

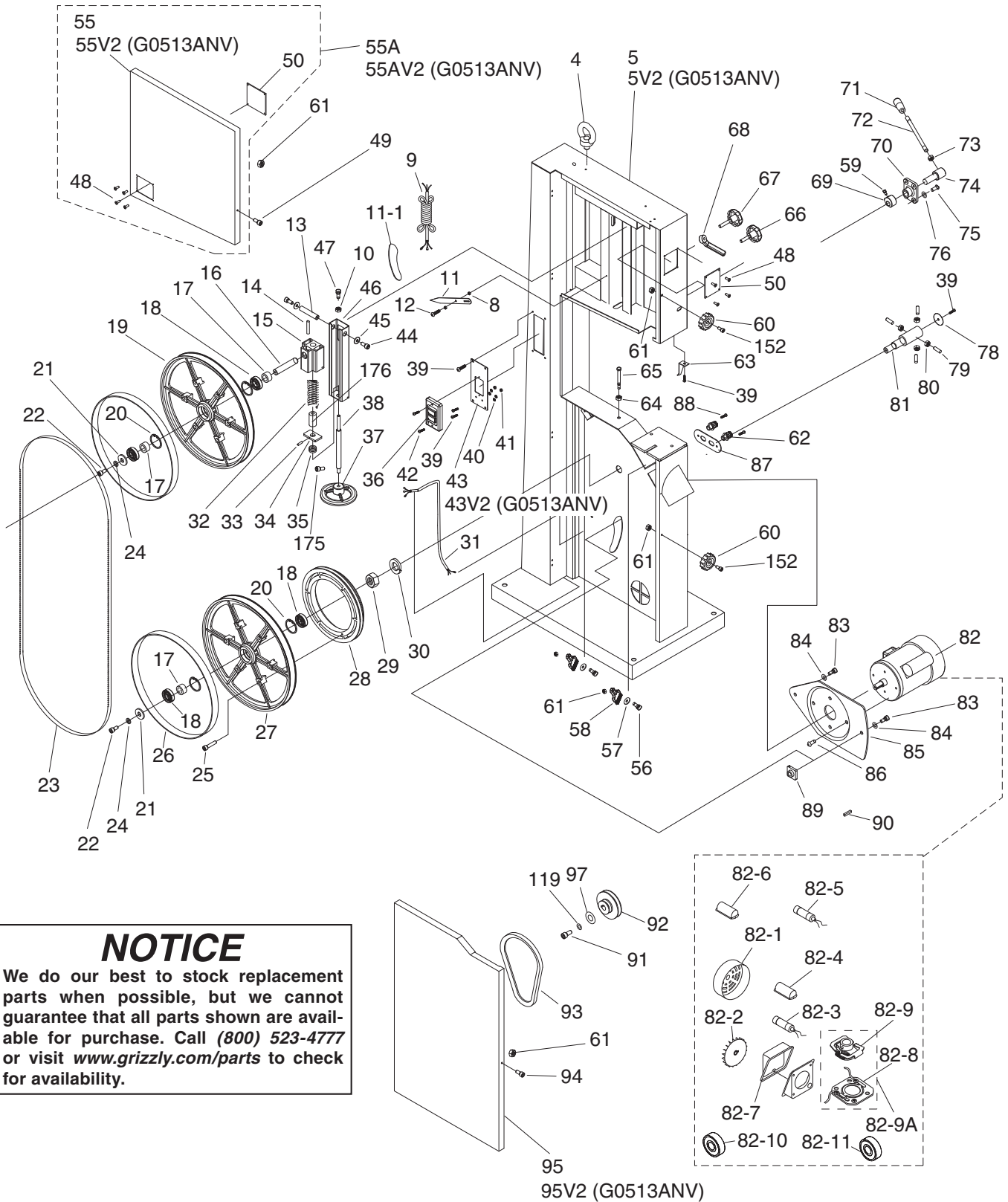

NOTICE
 We do our best to stock replacement parts when possible, but we cannot guarantee that all parts shown are available for purchase. Call (800) 523-4777 or visit www.grizzly.com/parts to check for availability.



G0513 & G0513ANV Main Parts List

REF	PART #	DESCRIPTION
4	P0513004	LIFTING EYE BOLT M10-1.5
5	P0513005	MACHINE BODY (G0513)
5V2	P0513ANV005V2	MACHINE BODY V2.04.17 (G0513ANV)
8	P0513008	FLAT WASHER 6MM
9	P0513009	POWER CORD 14G 3W 72"
10	P0513010	HEX NUT M6-1
11	P0513011	POINTER
12	P0513012	STEP SCREW M4-.7 X 5
13	P0513013	HINGE SHAFT
14	P0513014	ROLL PIN 5 X 36
15	P0513015	UPPER WHEEL SHAFT HINGE
16	P0513016	UPPER WHEEL SHAFT
17	P0513017	BUSHING
18	P0513018	BALL BEARING 6204-2RS
19	P0513019	UPPER WHEEL 17"
20	P0513020	INT RETAINING RING 47MM
21	P0513021	WHEEL FLAT WASHER 8MM
22	P0513022	CAP SCREW M8-1.25 X 16
23	P0513023	SAW BLADE 131.5" X 1/2" 6TPI HOOK
24	P0513024	LOCK WASHER 8MM
25	P0513025	HEX BOLT M6-1 X 30
26	P0513026	URETHANE TIRE 17" 1-PAIR
27	P0513027	LOWER WHEEL 17"
28	P0513028	LOWER WHEEL PULLEY
29	P0513029	HEX NUT 1-14
30	P0513030	LOCK WASHER 1"
31	P0513031	MOTOR CORD 14G 3W
32	P0513032	COMPRESSION SPRING 7 X 8 X 90
33	P0513033	ROLL PIN 3 X 16
34	P0513034	ALIGNMENT PLATE
35	P0513035	THRUST BEARING 51201
36	P0513036	2-BUTTON POWER SWITCH
37	P0513037	TENSION HANDWHEEL
38	P0513038	TENSION ADJUSTING ROD
39	P0513039	FLANGE SCREW M5-.8 X 10
40	P0513040	EXT TOOTH WASHER 5MM
41	P0513041	HEX NUT M5-.8
42	P0513042	FLANGE SCREW M5-.8 X 16
43	P0513043	SWITCH BACK PLATE
43V2	P0513043V2	SWITCH BACK PLATE V2.04.17 (G0513ANV)
44	P0513044	HEX BOLT M8-1.25 X 16
45	P0513045	FLAT WASHER 8MM
46	P0513046	UPPER WHEEL SLIDING BRACKET
47	P0513047	HEX BOLT M6-1 X 25
48	P0513048	STEEL BLIND RIVET 3 X 13MM
49	P0513049	HEX BOLT M6-1 X 10
50	P0513050	CLEAR WINDOW
55	P0513055	UPPER WHEEL COVER (G0513)
55V2	P0513ANV055V2	UPPER WHEEL COVER V2.04.17 (G0513ANV)
55A	P0513055A	UPPER WHEEL COVER ASSY (G0513)
55AV2	P0513ANV055AV2	UPPER WHEEL COVER ASSY V2.04.17 (G0513ANV)
56	P0513056	HEX BOLT M6-1 X 10
57	P0513057	FLAT WASHER 6MM
58	P0513058	WHEEL BRUSH

REF	PART #	DESCRIPTION
59	P0513059	HEX BOLT M6-1 X 25
60	P0513060	STAR KNOB
61	P0513061	LOCK NUT M6-1
62	P0513062	STRAIN RELIEF 16MM STRAIGHT LT
63	P0513063	HEIGHT POINTER
64	P0513064	HEX NUT M8-1.25
65	P0513065	HEX BOLT M8-1.25 X 100
66	P0513066	STAR KNOB BOLT M10-1.5 X 20
67	P0513067	STAR KNOB BOLT M10-1.5 X 55
68	P0513068	THREADED HANDLE M10-1.5
69	P0513069	CAM
70	P0513070	PILLOW BLOCK
71	P0513071	HANDLE M12-1.75
72	P0513072	LEVER
73	P0513073	HEX NUT M12-1.75
74	P0513074	LEVER HUB
75	P0513075	CAP SCREW M8-1.25 X 20
76	P0513076	LOCK WASHER 8MM
78	P0513078	SHAFT COVER
79	P0513079	SET SCREW M8-1.25 X 20
80	P0513080	HEX NUT M8-1.25
81	P0513081	LOWER WHEEL SHAFT
82	P0513082	MOTOR 2HP 110V/220V 1-PH
82-1	P0513082-1	MOTOR FAN COVER
82-2	P0513082-2	MOTOR FAN
82-3	P0513082-3	S CAPACITOR 300M 250V 1-1/2 X 2-3/8
82-4	P0513082-4	S CAPACITOR COVER
82-5	P0513082-5	R CAPACITOR 40M 250V 1-1/2 X 2-3/4
82-6	P0513082-6	R CAPACITOR COVER
82-7	P0513082-7	MOTOR JUNCTION BOX
82-8	P0513082-8	CONTACT PLATE
82-9	P0513082-9	CENTRIFUGAL SWITCH 5/8-1725
82-9A	P0513082-9A	CENTRIFUGAL SWITCH W/CONT PLATE
82-10	P0513082-10	BALL BEARING 6203ZZ
82-11	P0513082-11	BALL BEARING 6205ZZ
83	P0513083	HEX BOLT M5-.8 X 16
84	P0513084	LOCK WASHER 5MM
85	P0513085	MOTOR MOUNT BRACKET
86	P0513086	CAP SCREW M8-1.25 X 20
87	P0513087	STRAIN RELIEF PLATE 2-HOLE
88	P0513088	FLANGE SCREW M5-.8 X 10
89	P0513089	PILLOW BLOCK
90	P0513090	KEY 5 X 5 X 35
91	P0513091	HEX BOLT M8-1.25 X 20 LH
92	P0513092	MOTOR PULLEY TYPE-A 3.5"
93	P0513093	V-BELT A42
94	P0513094	HEX BOLT M6-1 X 10
95	P0513095	LOWER WHEEL COVER (G0513)
95V2	P0513ANV095V2	LOWER WHEEL COVER V2.04.17 (G0513ANV)
97	P0513097	FLAT WASHER 8MM
119	P0513119	FLAT WASHER 8MM
152	P0513152	HEX BOLT M6-1 X 20
175	P0513175	HEX BOLT M6-1 X 20
176	P0513176	BUSHING



G0513 & G0513ANV Table, Trunnion & Lower Blade Guides

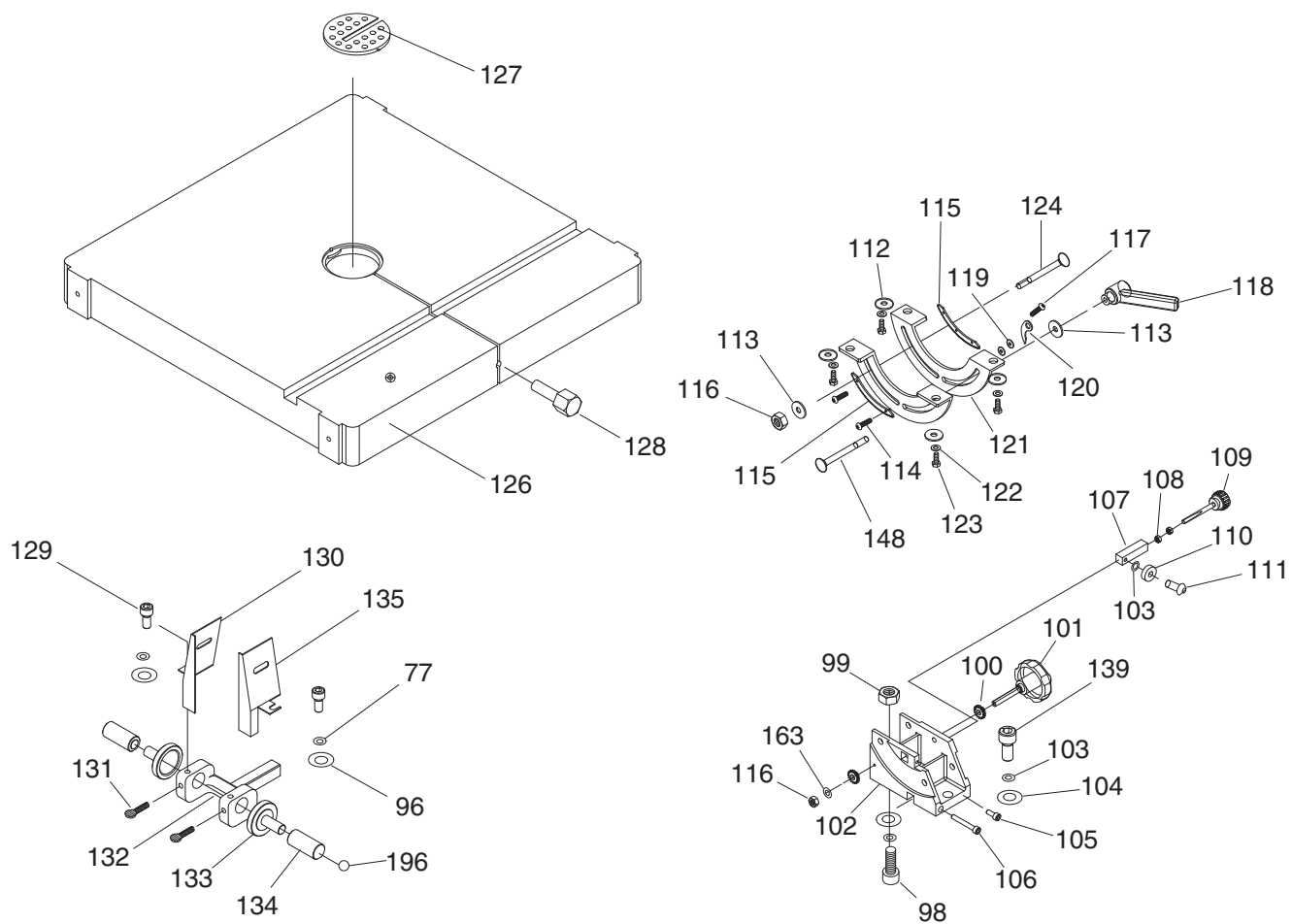

REF	PART #	DESCRIPTION
77	P0513077	LOCK WASHER 8MM
96	P0513096	FLAT WASHER 8MM
98	P0513098	CAP SCREW M10-1.5 X 35
99	P0513099	HEX NUT M10-1.5
100	P0513100	TRUNNION GEAR
101	P0513101	STAR KNOB BOLT
102	P0513102	TRUNNION SUPPORT BRACKET
103	P0513103	LOCK WASHER 10MM
104	P0513104	FLAT WASHER 10MM
105	P0513105	CAP SCREW M6-1 X 15
106	P0513106	CAP SCREW M6-1 X 50
107	P0513107	ALIGNMENT ROD
108	P0513108	HEX NUT M6-1
109	P0513109	ADJUSTMENT KNOB BOLT M6-1
110	P0513110	BALL BEARING 6000ZZ
111	P0513111	BUTTON HD CAP SCR M10-1.5 X 20
112	P0513112	FLAT WASHER 8MM
113	P0513113	FLAT WASHER 8MM
114	P0513114	PHLP HD SCR M4-.7 X 6
115	P0513115	GEAR PLATE
116	P0513116	LOCK NUT M8-1.25
117	P0513117	PHLP HD SCR M4-.7 x 6

REF	PART #	DESCRIPTION
118	P0513118	LOCK HANDLE M8-1.25
119	P0513119	FLAT WASHER 8MM
120	P0513120	POINTER
121	P0513121	TRUNNION PLATE
122	P0513122	LOCK WASHER 8MM
123	P0513123	CAP SCREW M8-1.25 X 16
124	P0513124	CARRIAGE BOLT M8-1.25 X 80
126	P0513126	TABLE 17" X 17"
126	P0513ANV126	TABLE 17" X 17" (G0513ANV)
127	P0513127	TABLE INSERT
128	P0513128	TABLE PIN
129	P0513129	HEX BOLT M8-1.25 X 20 LH
130	P0513130	LEFT GUARD
131	P0513131	THUMB SCREW M6-1 X 16
132	P0513132	LOWER BLADE GUIDE SUPPORT
133	P0513133	BLADE GUIDE
134	P0513134	GUIDE ADJUSTMENT SHAFT
135	P0513135	RIGHT GUARD
139	P0513139	CAP SCREW M10-1.5 X 30
148	P0513148	CARRIAGE BOLT M8-1.25 X 85
163	P0513163	LOCK WASHER 8MM
196	P0513196	STEEL BALL 5MM



G0513 & G0513ANV Fence

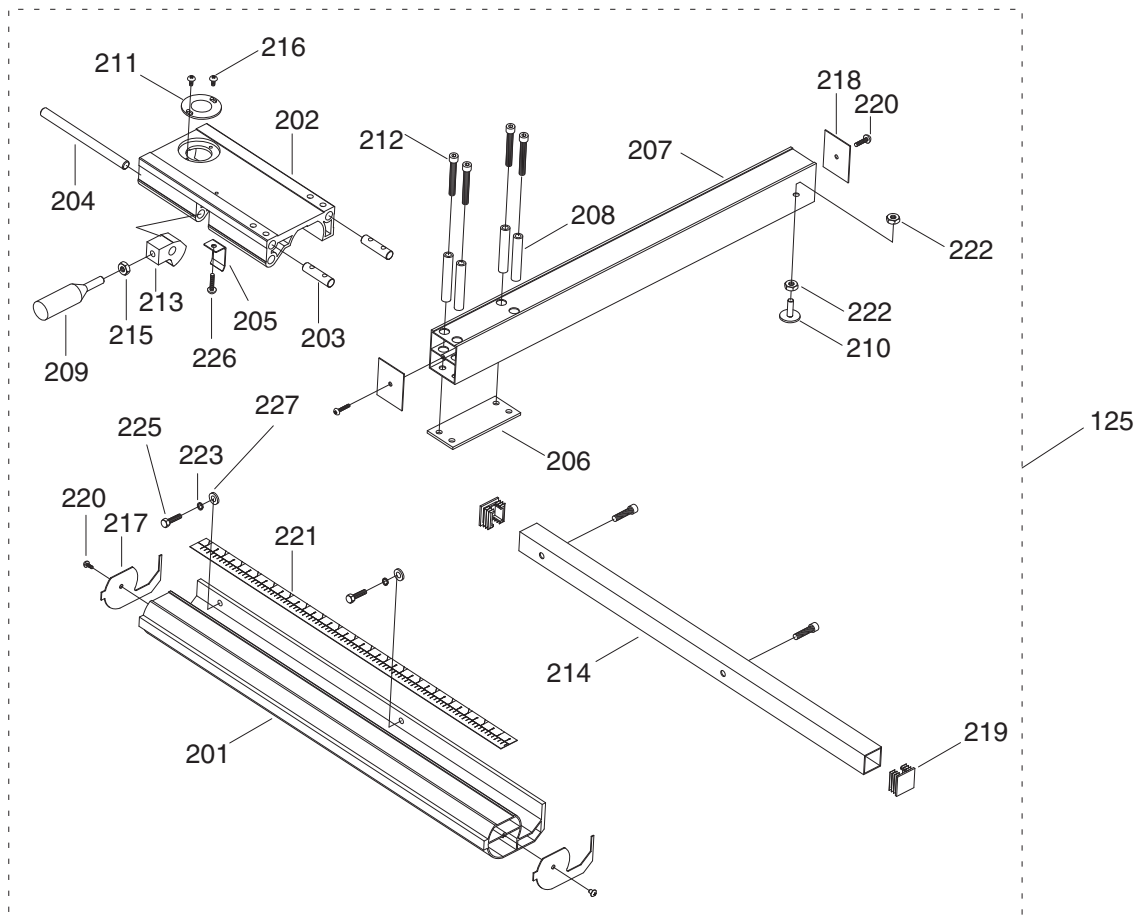

REF	PART #	DESCRIPTION
125	P0513125	FENCE ASSEMBLY W/RAILS
201	P0513201	FRONT FENCE RAIL
202	P0513202	FENCE BASE
203	P0513203	ALIGNMENT SHAFT
204	P0513204	LOCK BLOCK SHAFT
205	P0513205	SPRING PLATE
206	P0513206	SPACER PLATE
207	P0513207	FENCE
208	P0513208	SLEEVE
209	P0513209	FENCE LOCK HANDLE
210	P0513210	RAIL PAD
211	P0513211	CONVEX WINDOW
212	P0513212	CAP SCREW M6-1 X 55
213	P0513213	LOCK CAM

REF	PART #	DESCRIPTION
214	P0513214	REAR FENCE RAIL
215	P0513215	HEX NUT M6-1
216	P0513216	HEX NUT M18-1.5
217	P0513217	FRONT RAIL END CAP
218	P0513218	FENCE END CAP
219	P0513219	REAR RAIL END CAP
220	P0513220	TAP SCREW M3.5 X 8
221	P0513221	FENCE SCALE
222	P0513222	HEX NUT M6-1
223	P0513223	LOCK WASHER 6MM
225	P0513225	HEX BOLT M6-1 X 20
226	P0513226	FLANGE SCREW M4-.7 X 10
227	P0513227	FLAT WASHER 6MM



G0513 & G0513ANV Upper Blade Guides & Miter Gauge

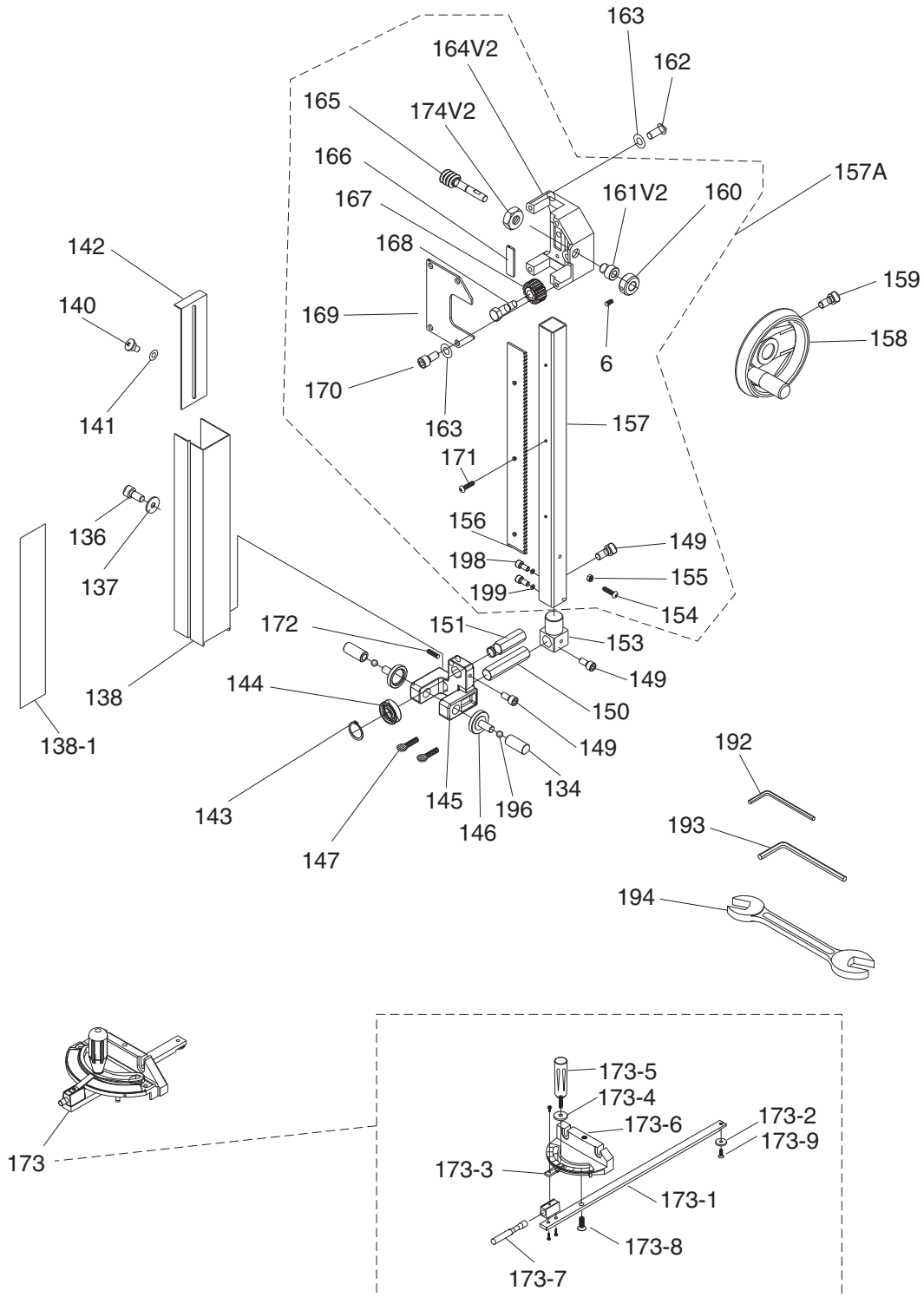

G0513 & G0513ANV Upper Blade Guides & Miter Gauge Parts List

REF	PART #	DESCRIPTION
6	P0513006	SET SCREW M5-.8 X 5
134	P0513134	GUIDE ADJUSTMENT SHAFT
136	P0513136	CAP SCREW M8-1.25 X 80
137	P0513137	FLAT WASHER 8MM
138	P0513138	UPPER BLADE GUARD (G0513/G0513P)
138	P0513ANV138	UPPER BLADE GUARD (G0513ANV)
138-1	P0513138-1	BLADE GUARD SCALE
140	P0513140	STEP SCREW M4-.7 X 5
141	P0513141	FIBER WASHER 5MM
142	P0513142	SLIDING PLATE (G0513/G0513P)
142	P0513ANV142	SLIDING PLATE (G0513ANV)
143	P0513143	EXT RETAINING RING 15MM
144	P0513144	BALL BEARING 6202ZZ
145	P0513145	UPPER BLADE GUIDE SUPPORT
146	P0513146	BLADE GUIDE
147	P0513147	THUMB SCREW M6-1 X 16
149	P0513149	CAP SCREW M6-1 X 15
150	P0513150	ADJUSTMENT SHAFT
151	P0513151	UPPER SPACING SLEEVE
153	P0513153	UPPER GUIDE SUPPORT BLOCK
154	P0513154	PHLP HD SCR M4-.7 X 10
155	P0513155	HEX NUT M4-.7
156	P0513156	RACK
157A	P0513157A	GUIDE POST ASSEMBLY
157	P0513157	GUIDE POST
158	P0513158	ELEVATION HANDWHEEL
159	P0513159	HEX BOLT M6-1 X 20
160	P0513160	PINION GEAR STEP BOLT
161V2	P0513161V2	THREADED BUSHING V2.06.09

REF	PART #	DESCRIPTION
162	P0513162	CAP SCREW M8-1.25 X 20
163	P0513163	LOCK WASHER 8MM
164V2	P0513164V2	THREADED GUIDE BRACKET 14MM V2.06.09
165	P0513165	WORM CYLINDER
166	P0513166	FIXED PLATE
167	P0513167	PINION GEAR 15T
168	P0513168	PINION GEAR STEP BOLT
169	P0513169	BRACKET COVER
170	P0513170	CAP SCREW M8-1.25 X 16
171	P0513171	PHLP HD SCR M4-.7 X 8
172	P0513172	SET SCREW M6-1 X 16
173	P0513173	MITER GAUGE ASSY
173-1	P0513173-1	GUIDE BAR
173-2	P0513173-2	T-SLOT WASHER 5MM
173-3	P0513173-3	INDICATOR
173-4	P0513173-4	NYLON WASHER 1/4"
173-5	P0513173-5	MITER GAUGE HANDLE 1/4"-20
173-6	P0513173-6	MITER GAUGE BODY
173-7	P0513173-7	INDEXING PIN
173-8	P0513173-8	PHLP HD SCR M6-1 X 6
173-9	P0513173-9	FLANGE SCREW M5-.8 X 8
174V2	P0513174V2	HEX NUT M16-1.5 THIN
192	P0513192	HEX WRENCH 5MM
193	P0513193	HEX WRENCH 8MM
194	P0513194	WRENCH 10 X 13MM OPEN-END
196	P0513196	STEEL BALL 5MM
198	P0513198	CAP SCREW M5-.8 X 12
199	P0513199	FLAT WASHER 5MM



G0513 Labels

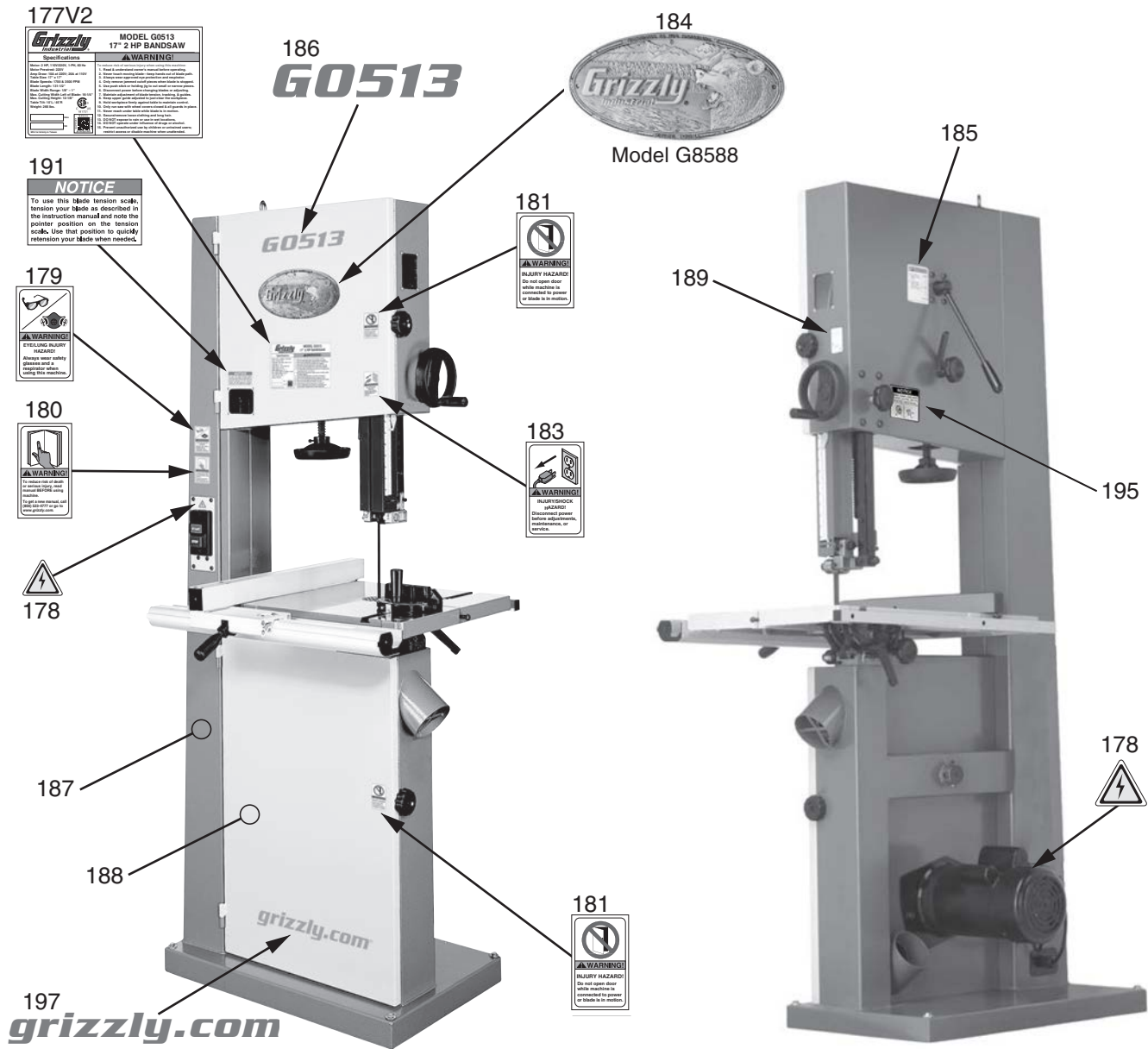

REF	PART #	DESCRIPTION
177V2	P0513177V2	MACHINE ID LABEL V2.07.18
178	P0513178	ELECTRICITY LABEL
179	P0513179	GLASSES/RESPIRATOR LABEL
180	P0513180	READ MANUAL LABEL
181	P0513181	DOOR WARNING LABEL
183	P0513183	DISCONNECT POWER LABEL
184	P0513184	GRIZZLY NAMEPLATE-SMALL
185	P0513185	SAW TENSION LABEL

REF	PART #	DESCRIPTION
186	P0513186	MODEL NUMBER LABEL
187	P0513187	TOUCH-UP PAINT, GRIZZLY GREEN
188	P0513188	TOUCH-UP PAINT, LIGHT GRAY
189	P0513189	GUIDE POST ADJUST LABEL
191	P0513191	BLADE TENSION SCALE LABEL
195	P0513195	GUIDE POST LOCK LABEL
197	P0513197	GRIZZLY.COM LABEL

⚠ WARNING

Safety labels help reduce the risk of serious injury caused by machine hazards. If any label comes off or becomes unreadable, the owner of this machine **MUST** replace it in the original location before resuming operations. For replacements, contact (800) 523-4777 or www.grizzly.com.



G0513ANV Labels

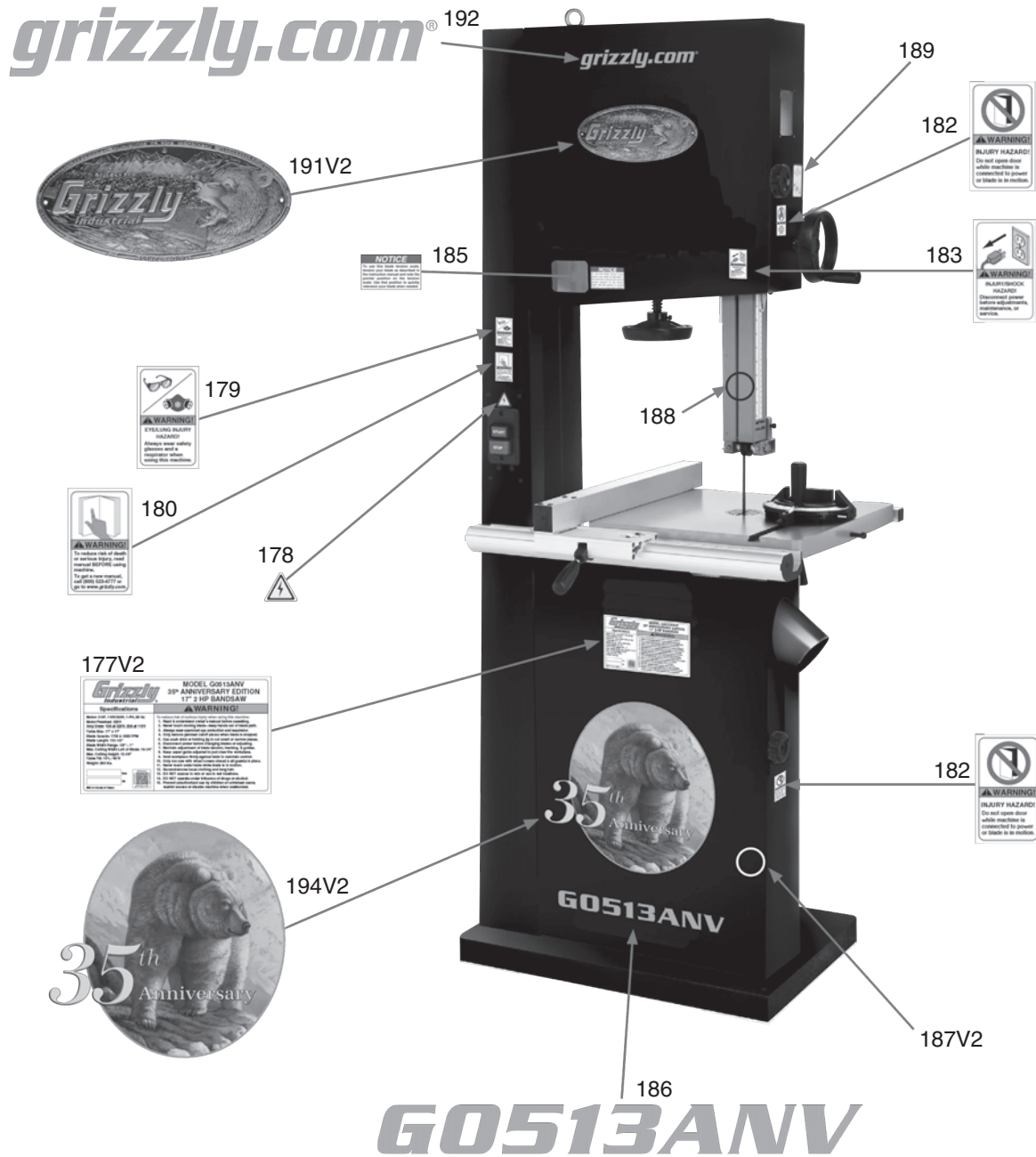

G0513ANV

REF	PART #	DESCRIPTION
177V2	P0513ANV177V2	MACHINE ID LABEL V2.04.17
178	P0513ANV178	ELECTRICITY LABEL
179	P0513ANV179	SAFETY GLASSES/RESPIRATOR LABEL
180	P0513ANV180	READ MANUAL LABEL
182	P0513ANV182	DONT OPEN LABEL
183	P0513ANV183	UNPLUG BANDSAW LABEL
185	P0513ANV185	SAW TENSION LABEL

REF	PART #	DESCRIPTION
186	P0513ANV186	MODEL NUMBER LABEL
187V2	P0513ANV187V2	TOUCH-UP PAINT, 35TH ANV ED. V2.04.17
188	P0513ANV188	ORANGE TOUCH-UP PAINT, PANTONE 151C
189	P0513ANV189	GUIDE POST ADJUST LABEL
191V2	P0513ANV191V2	GRIZZLY LOGO NAMEPLATE V2.04.17
192	P0513ANV192	ORANGE GRIZZLY.COM LABEL
194V2	P0513ANV194V2	35TH ANNIVERSARY LABEL V2.04.17



G0513X2 Main

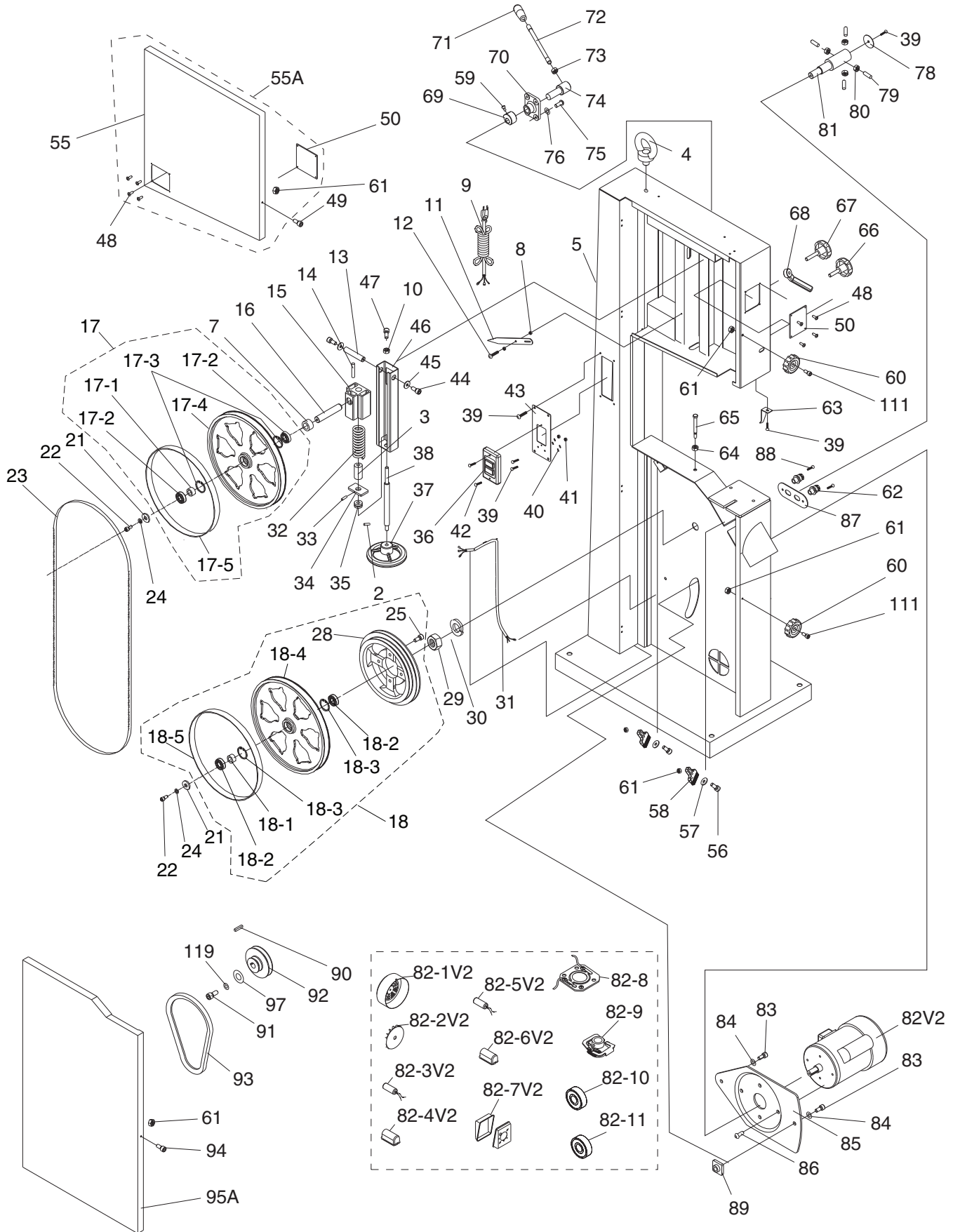

G0513X2 Main Parts List

REF	PART #	DESCRIPTION
2	P0513X2002	SET SCREW M6-1 X 10
3	P0513X2003	BUSHING
4	P0513X2004	LIFTING EYE BOLT M10-1.5
5	P0513X2005	MACHINE BODY
7	P0513X2007	BUSHING
8	P0513X2008	FLAT WASHER 6MM
9	P0513X2009	POWER CORD 14G 3W 72"
10	P0513X2010	HEX NUT M6-1
11	P0513X2011	POINTER
12	P0513X2012	STEP SCREW M4-.7 X 5
13	P0513X2013	HINGE SHAFT
14	P0513X2014	ROLL PIN 5 X 36
15	P0513X2015	UPPER WHEEL SHAFT HINGE
16	P0513X2016	UPPER WHEEL SHAFT
17	P0513X2017	UPPER WHEEL ASSEMBLY
17-1	P0513X2017-1	BUSHING
17-2	P0513X2017-2	BALL BEARING 6204-2RS
17-3	P0513X2017-3	INT RETAINING RING 47MM
17-4	P0513X2017-4	UPPER WHEEL 17"
17-5	P0513X2017-5	URETHANE TIRE 17" 1-PAIR
18	P0513X2018	LOWER WHEEL ASSEMBLY
18-1	P0513X2018-1	BUSHING
18-2	P0513X2018-2	BALL BEARING 6204-2RS
18-3	P0513X2018-3	INT RETAINING RING 47MM
18-4	P0513X2018-4	LOWER WHEEL 17"
18-5	P0513X2018-5	URETHANE TIRE 17" 1-PAIR
21	P0513X2021	WHEEL FLAT WASHER 8MM
22	P0513X2022	CAP SCREW M8-1.25 X 16
23	P0513X2023	SAW BLADE 131.5" X 1/2" 6TPI HOOK
24	P0513X2024	LOCK WASHER 8MM
25	P0513X2025	CAP SCREW M8-1.25 X 20
28	P0513X2028	LOWER WHEEL ASSEMBLY
29	P0513X2029	HEX NUT 1-14
30	P0513X2030	LOCK WASHER 1"
31	P0513X2031	MOTOR CORD 14G 3W
32	P0513X2032	COMPRESSION SPRING 7 X 8 X 90
33	P0513X2033	ROLL PIN 3 X 16
34	P0513X2034	ALIGNMENT PLATE
35	P0513X2035	THRUST BEARING 51201
36	P0513X2036	2-BUTTON START/STOP SWITCH
37	P0513X2037	TENSION HANDWHEEL
38	P0513X2038	TENSION ADJUSTING ROD
39	P0513X2039	FLANGE SCREW M5-.8 X 10
40	P0513X2040	EXT TOOTH WASHER 5MM
41	P0513X2041	HEX NUT M5-.8
42	P0513X2042	FLANGE SCREW M5-.8 X 16
43	P0513X2043	SWITCH BACK PLATE
44	P0513X2044	CAP SCREW M8-1.25 X 16
45	P0513X2045	FENDER WASHER 8MM
46	P0513X2046	UPPER WHEEL SLIDING BRACKET
47	P0513X2047	CAP SCREW M8-1.25 X 50
48	P0513X2048	STEEL BLIND RIVET 3 X 13MM
49	P0513X2049	CAP SCREW M6-1 X 10
50	P0513X2050	CLEAR WINDOW
55A	P0513X2055A	UPPER WHEEL COVER ASSY

REF	PART #	DESCRIPTION
55	P0513X2055	UPPER WHEEL COVER
56	P0513X2056	HEX BOLT M6-1 X 25
57	P0513X2057	FLAT WASHER 6MM
58	P0513X2058	WHEEL BRUSH
59	P0513X2059	CAP SCREW M6-1 X 25
60	P0513X2060	STAR KNOB
61	P0513X2061	LOCK NUT M6-1
62	P0513X2062	STRAIN RELIEF 16MM STRAIGHT LT
63	P0513X2063	HEIGHT POINTER
64	P0513X2064	HEX NUT M8-1.25
65	P0513X2065	HEX BOLT M8-1.25 X 90
66	P0513X2066	STAR KNOB BOLT M10-1.5 X 20
67	P0513X2067	STAR KNOB BOLT M10-1.5 X 55
68	P0513X2068	THREADED HANDLE M10-1.5
69	P0513X2069	CAM
70	P0513X2070	PILLOW BLOCK
71	P0513X2071	HANDLE M12-1.75
72	P0513X2072	LEVER
73	P0513X2073	HEX NUT M12-1.75
74	P0513X2074	LEVER HUB
75	P0513X2075	BUTTON HD CAP SCR M8-1.25 X 20
76	P0513X2076	LOCK WASHER 8MM
78	P0513X2078	SHAFT COVER
79	P0513X2079	SET SCREW M8-1.25 X 20
80	P0513X2080	HEX NUT M8-1.25
81	P0513X2081	LOWER WHEEL SHAFT
82V2	P0513X2082V2	MOTOR 2HP 110V/220V 1-PH V2.01.10
82-1V2	P0513X2082-1V2	MOTOR FAN COVER V2.01.10
82-2V2	P0513X2082-2V2	MOTOR FAN V2.01.10
82-3V2	P0513X2082-3V2	S CAPACITOR 300M 250V 1-1/2 X 2-3/8 V2.01.10
82-4V2	P0513X2082-4V2	S CAPACITOR COVER V2.01.10
82-5V2	P0513X2082-5V2	R CAPACITOR 40M 250V 1-3/8 X 2-5/8 V2.01.10
82-6V2	P0513X2082-6V2	R CAPACITOR COVER V2.01.10
82-7V2	P0513X2082-7V2	MOTOR JUNCTION BOX V2.01.10
82-8	P0513X2082-8	CONTACT PLATE 5/8
82-9	P0513X2082-9	CENTRIFUGAL SWITCH 5/8-1725
82-10	P0513X2082-10	BALL BEARING 6203ZZ
82-11	P0513X2082-11	BALL BEARING 6205ZZ
83	P0513X2083	HEX BOLT M10-1.5 X 25
84	P0513X2084	LOCK WASHER 10MM
85	P0513X2085	MOTOR MOUNT BRACKET
86	P0513X2086	BUTTON HD CAP SCR M8-1.25 X 20
87	P0513X2087	STRAIN RELIEF PLATE 2-HOLE
88	P0513X2088	FLANGE SCREW M5-.8 X 10
89	P0513X2089	PILLOW BLOCK
90	P0513X2090	KEY 5 X 5 X 35
91	P0513X2091	HEX BOLT M8-1.25 X 20 LH
92	P0513X2092	MOTOR PULLEY TYPE-A 3.5"
93	P0513X2093	V-BELT A42
94	P0513X2094	CAP SCREW M6-1 X 10
95A	P0513X2095A	LOWER WHEEL COVER
97	P0513X2097	FENDER WASHER 8MM
111	P0513X2111	CAP SCREW M6-1 X 20
119	P0513X2119	LOCK WASHER 4MM



G0513X2 Labels

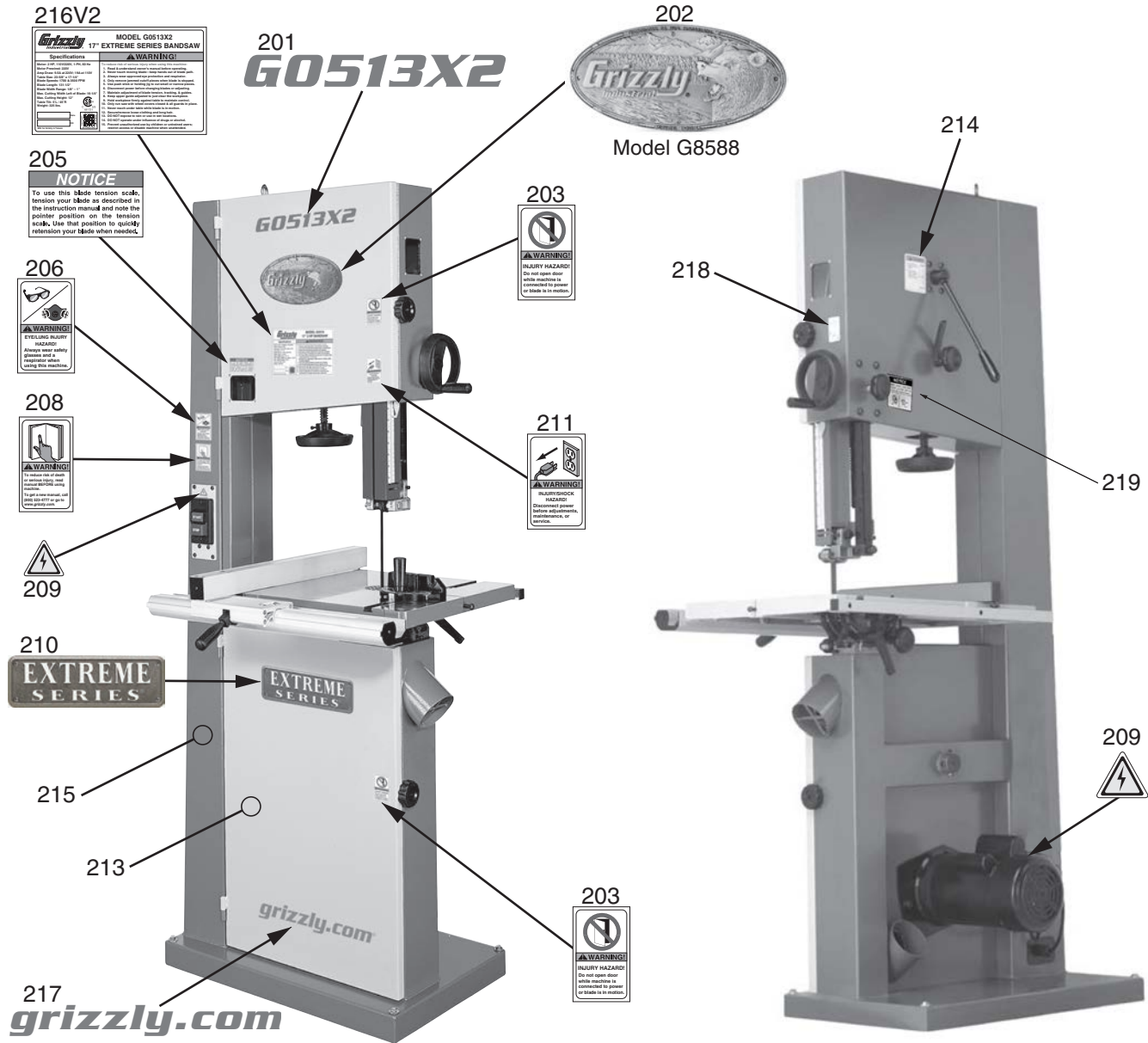

REF	PART #	DESCRIPTION
201	P0513X2201	MODEL NUMBER LABEL
202	P0513X2202	GRIZZLY LOGO PLATE
203	P0513X2203	OPEN DOOR LABEL
205	P0513X2205	SCALE DIRECTIONS LABEL
206	P0513X2206	SAFETY GLASSES LABEL
208	P0513X2208	READ MANUAL LABEL
209	P0513X2209	ELECTRICITY LABEL
210	P0513X2210	EXTREME SERIES PLATE

REF	PART #	DESCRIPTION
211	P0513X2211	DISCONNECT POWER LABEL
213	P0513X2213	TOUCH-UP PAINT, GRIZZLY PUTTY
214	P0513X2214	TENSION ADJ LABEL
215	P0513X2215	TOUCH-UP PAINT, GRIZZLY GREEN
216V2	P0513X2216V2	MACHINE ID LABEL V2.09.18
217	P0513X2217	GRIZZLY.COM LABEL
218	P0513X2218	GUIDE POST ADJUST LABEL
219	P0513X2219	GUIDE POST LOCK LABEL

⚠ WARNING

Safety labels help reduce the risk of serious injury caused by machine hazards. If any label comes off or becomes unreadable, the owner of this machine **MUST** replace it in the original location before resuming operations. For replacements, contact (800) 523-4777 or www.grizzly.com.



G0513X2B Main

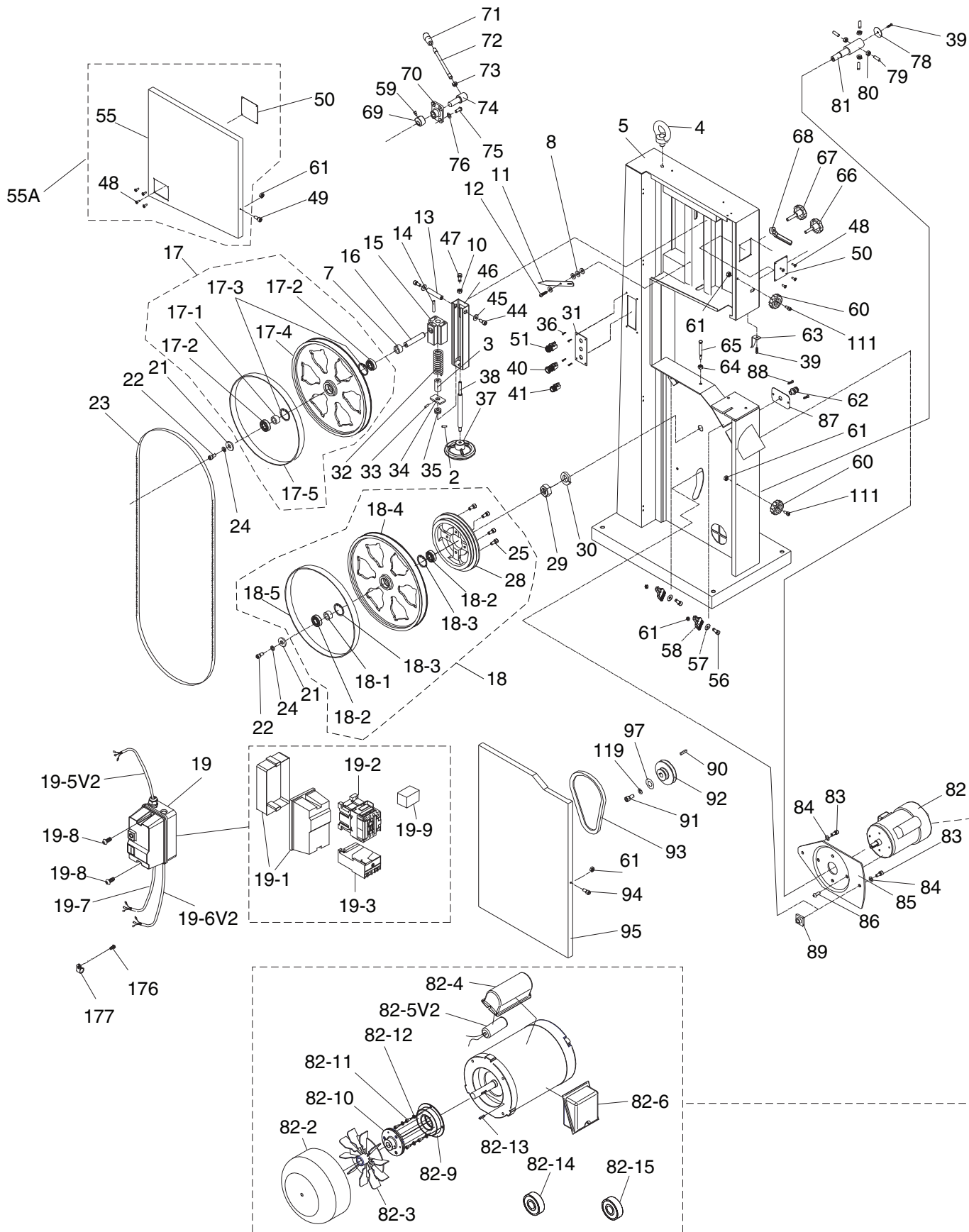

G0513X2B Main Parts List

REF	PART #	DESCRIPTION
2	P0513X2B002	SET SCREW M6-1 X 10
3	P0513X2B003	BUSHING
4	P0513X2B004	LIFTING EYE BOLT M10-1.5
5	P0513X2B005	MACHINE BODY
7	P0513X2B007	BUSHING
8	P0513X2B008	FLAT WASHER 6MM
10	P0513X2B010	HEX NUT M6-1
11	P0513X2B011	POINTER
12	P0513X2B012	STEP SCREW M4-.7 X 5
13	P0513X2B013	HINGE SHAFT
14	P0513X2B014	ROLL PIN 5 X 35
15	P0513X2B015	UPPER WHEEL SHAFT HINGE
16	P0513X2B016	UPPER WHEEL SHAFT
17	P0513X2B017	UPPER WHEEL ASSEMBLY
17-1	P0513X2B017-1	BUSHING
17-2	P0513X2B017-2	BALL BEARING 6204-2RS
17-3	P0513X2B017-3	INT RETAINING RING 47MM
17-4	P0513X2B017-4	UPPER WHEEL 17"
17-5	P0513X2B017-5	URETHANE TIRE 17" 1-PAIR
18	P0513X2B018	LOWER WHEEL ASSEMBLY
18-1	P0513X2B018-1	BUSHING
18-2	P0513X2B018-2	BALL BEARING 6204-2RS
18-3	P0513X2B018-3	INT RETAINING RING 47MM
18-4	P0513X2B018-4	LOWER WHEEL 17"
18-5	P0513X2B018-5	URETHANE TIRE, 1-PAIR
19	P0513X2B019	MAG SWITCH ASSEMBLY MPE-18
19-1	P0513X2B019-1	MAG SWITCH COVER ASSEMBLY
19-2	P0513X2B019-2	CONTACTOR SDE MA-18 220V
19-3	P0513X2B019-3	OL RELAY SDE RA-20 8-12A
19-5V2	P0513X2B019-5V2	PWR CORD 14G 3W 6-15P V2.02.12
19-6V2	P0513X2B019-6V2	CONTROL CORD 16G 5W V2.05.11
19-7	P0513X2B019-7	MOTOR CORD 14G 5W
19-8	P0513X2B019-8	PHLP HD SCR M5-.8 X 10
19-9	P0513X2B019-9	RECTIFIER PU-23-2
21	P0513X2B021	WHEEL FLAT WASHER 8MM
22	P0513X2B022	CAP SCREW M8-1.25 X 16
23	P0513X2B023	SAW BLADE 131.5" X 1/2" 6TPI HOOK
24	P0513X2B024	LOCK WASHER 8MM
25	P0513X2B025	CAP SCREW M8-1.25 X 20
28	P0513X2B028	LOWER WHEEL PULLEY
29	P0513X2B029	HEX NUT 1-14
30	P0513X2B030	LOCK WASHER 1"
31	P0513X2B031	CONTROL PANEL PLATE
32	P0513X2B032	COMPRESSION SPRING 7 X 8 X 90
33	P0513X2B033	ROLL PIN 3 X 16
34	P0513X2B034	ALIGNMENT PLATE
35	P0513X2B035	THRUST BEARING 51201
36	P0513X2B036	TAP SCREW M4 X 10
37	P0513X2B037	TENSION HANDWHEEL
38	P0513X2B038	TENSION ADJUSTING ROD
39	P0513X2B039	FLANGE SCREW M5-.8 X 10
40	P0513X2B040	STOP BUTTON

REF	PART #	DESCRIPTION
41	P0513X2B041	START BUTTON
44	P0513X2B044	CAP SCREW M8-1.25 X 16
45	P0513X2B045	FENDER WASHER 8MM
46	P0513X2B046	UPPER WHEEL SLIDING BRACKET
47	P0513X2B047	CAP SCREW M6-1 X 25
48	P0513X2B048	STEEL BLIND RIVET 3 X 13MM
49	P0513X2B049	CAP SCREW M6-1 X 10
50	P0513X2B050	CLEAR WINDOW
51	P0513X2B051	KEY SWITCH
55A	P0513X2B055A	UPPER WHEEL COVER ASSY
55	P0513X2B055	UPPER WHEEL COVER
56	P0513X2B056	HEX BOLT M6-1 X 25
57	P0513X2B057	FLAT WASHER 6MM
58	P0513X2B058	WHEEL BRUSH
59	P0513X2B059	CAP SCREW M6-1 X 25
60	P0513X2B060	STAR KNOB
61	P0513X2B061	LOCK NUT M6-1
62	P0513X2B062	STRAIN RELIEF 16MM STRT LT
63	P0513X2B063	HEIGHT POINTER
64	P0513X2B064	HEX NUT M8-1.25
65	P0513X2B065	HEX BOLT M8-1.25 X 90
66	P0513X2B066	STAR KNOB BOLT M10-1.5 X 20
67	P0513X2B067	STAR KNOB BOLT M10-1.5 X 53
68	P0513X2B068	THREADED HANDLE M10-1.5
69	P0513X2B069	CAM
70	P0513X2B070	PILLOW BLOCK
71	P0513X2B071	HANDLE M12-1.75
72	P0513X2B072	LEVER
73	P0513X2B073	HEX NUT M12-1.75
74	P0513X2B074	LEVER HUB
75	P0513X2B075	BUTTON HD CAP SCR M8-1.25 X 20
76	P0513X2B076	LOCK WASHER 8MM
78	P0513X2B078	SHAFT COVER
79	P0513X2B079	SET SCREW M8-1.25 X 20
80	P0513X2B080	HEX NUT M8-1.25
81	P0513X2B081	LOWER WHEEL SHAFT
82	P0513X2B082	MOTOR 2HP 220V 1-PH W/BRAKE
82-2	P0513X2B082-2	MOTOR FAN COVER
82-3	P0513X2B082-3	MOTOR FAN
82-4	P0513X2B082-4	CAPACITOR COVER
82-5V2	P0513X2B082-5V2	R CAPACITOR 45M 400V 2 X 2-1/2
82-6	P0513X2B082-6	MOTOR JUNCTION BOX
82-9	P0513X2B082-9	MAGNETIC BRAKE YZG
82-10	P0513X2B082-10	BRAKE SHOE
82-11	P0513X2B082-11	CAP SCREW M6-1 X 12
82-12	P0513X2B082-12	LOCK WASHER 6MM
82-13	P0513X2B082-13	KEY 5 X 5 X 25
82-14	P0513X2B082-14	BALL BEARING 6203ZZ
82-15	P0513X2B082-15	BALL BEARING 6205ZZ
83	P0513X2B083	HEX BOLT M10-1.5 X 25
84	P0513X2B084	LOCK WASHER 10MM
85	P0513X2B085	MOTOR MOUNT BRACKET



G0513X2B Main Parts List

REF	PART #	DESCRIPTION
86	P0513X2B086	BUTTON HD CAP SCR M8-1.25 X 20
87	P0513X2B087	STRAIN RELIEF PLATE 1-HOLE
88	P0513X2B088	FLANGE SCREW M5-.8 X 10
89	P0513X2B089	PILLOW BLOCK
90	P0513X2B090	KEY 5 X 5 X 35
91	P0513X2B091	KEY 5 X 5 X 35
92	P0513X2B092	MOTOR PULLEY TYPE-A 3.5"
93	P0513X2B093	V-BELT A-42

REF	PART #	DESCRIPTION
94	P0513X2B094	CAP SCREW M6-1 X 10
95	P0513X2B095	LOWER WHEEL COVER
97	P0513X2B097	FENDER WASHER 8MM
111	P0513X2B111	CAP SCREW M6-1 X 20
119	P0513X2B119	LOCK WASHER 8MM
176	P0513X2B176	FLANGE SCREW M5-.8 X 10
177	P0513X2B177	STRAIN RELIEF 5/16" ELBOW LT

G0513X2B Labels

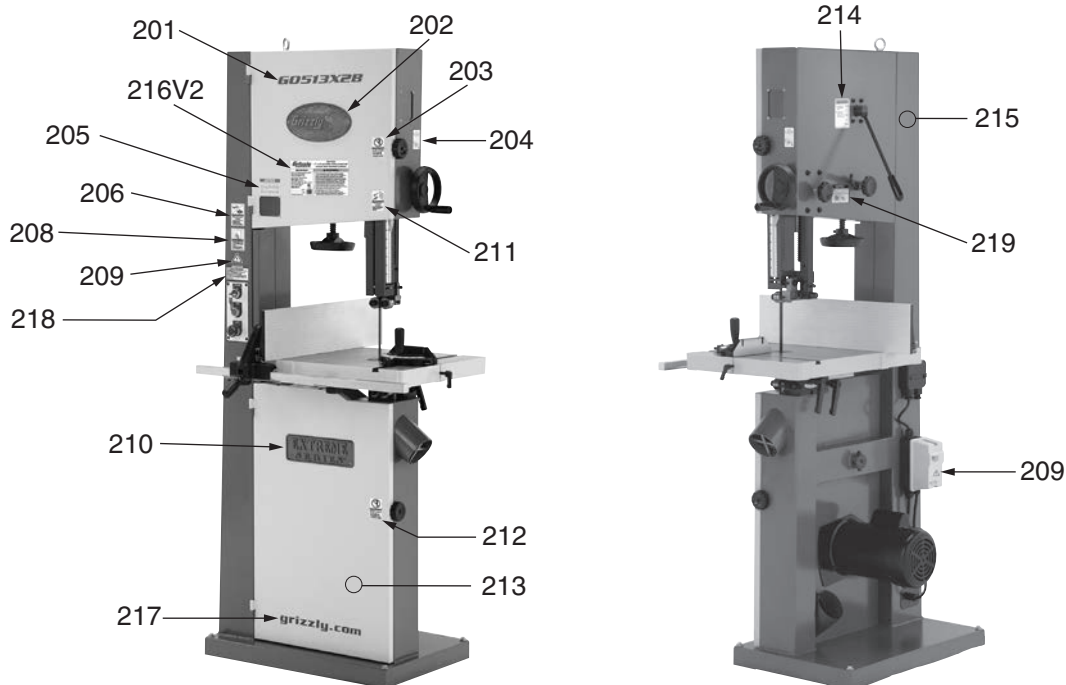

REF	PART #	DESCRIPTION
201	P0513X2B201	MODEL NUMBER LABEL
202	P0513X2B202	GRIZZLY LOGO PLATE
203	P0513X2B203	OPEN DOOR LABEL
204	P0513X2B204	GUARD ADJ LABEL
205	P0513X2B205	SCALE DIRECTIONS LABEL
206	P0513X2B206	SAFETY GLASSES LABEL
208	P0513X2B208	READ MANUAL LABEL
209	P0513X2B209	ELECTRICITY LABEL
210	P0513X2B210	EXTREME SERIES PLATE

REF	PART #	DESCRIPTION
211	P0513X2B211	DISCONNECT POWER LABEL
212	P0513X2B212	OPEN DOOR LABEL
213	P0513X2B213	TOUCH-UP PAINT, GRIZZLY PUTTY
214	P0513X2B214	TENSION ADJ LABEL
215	P0513X2B215	TOUCH-UP PAINT, GRIZZLY GREEN
216V2	P0513X2B216V2	MACHINE ID LABEL V2.05.11
217	P0513X2B217	GRIZZLY.COM LABEL
218	P0513X2B218	MAGNETIC BRAKE NOTICE
219	P0513X2B219	GUIDE POST LOCK LABEL

WARNING

Safety labels help reduce the risk of serious injury caused by machine hazards. If any label comes off or becomes unreadable, the owner of this machine **MUST** replace it in the original location before resuming operations. For replacements, contact (800) 523-4777 or www.grizzly.com.



G0513X2BF Main

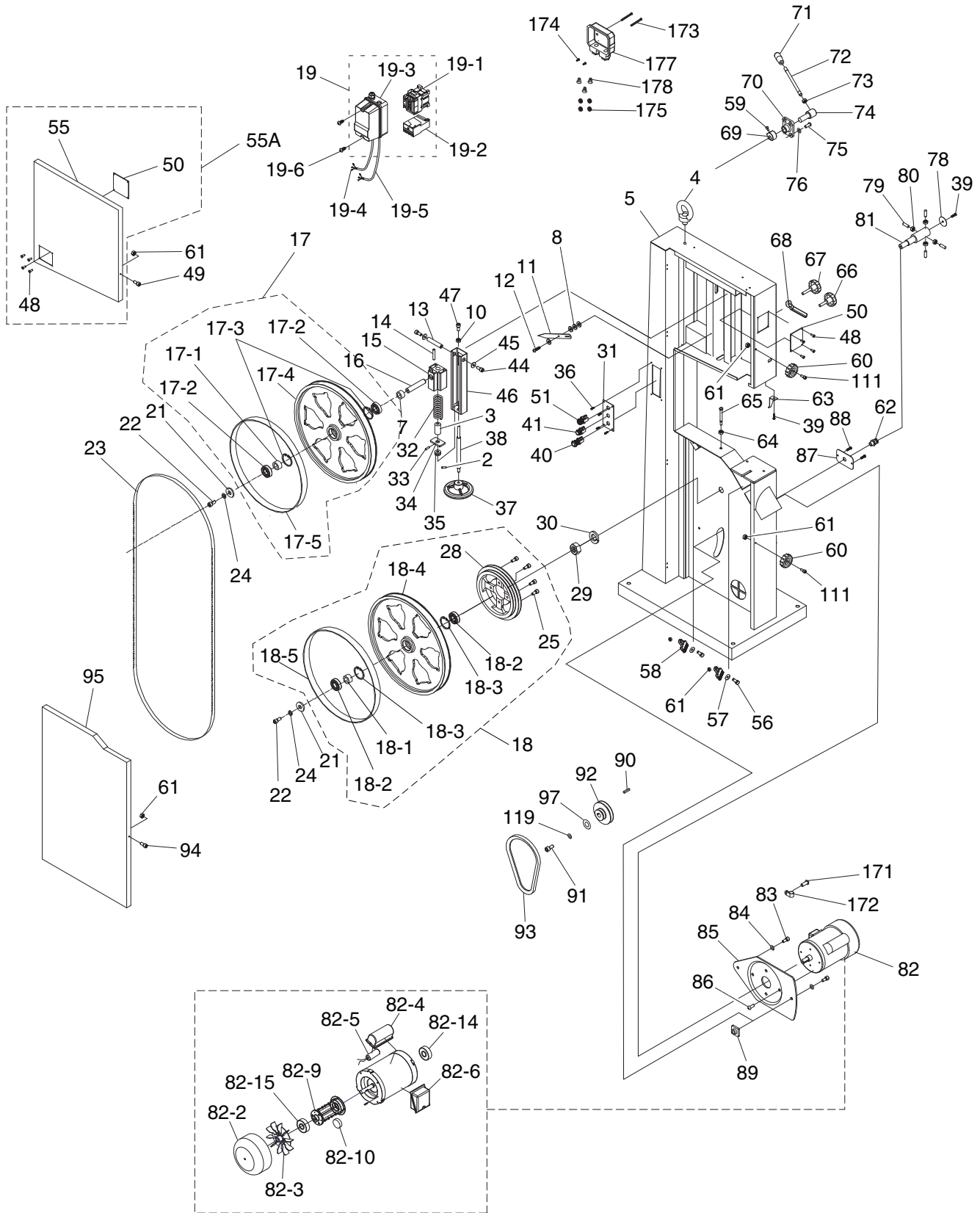

G0513X2BF Main Parts List

REF PART #	DESCRIPTION
2	P0513X2BF002 SET SCREW M6-1 X 10
3	P0513X2BF003 BUSHING
4	P0513X2BF004 LIFTING EYE BOLT M10-1.5
5	P0513X2BF005 MACHINE BODY
7	P0513X2BF007 BUSHING
8	P0513X2BF008 FLAT WASHER 6MM
10	P0513X2BF010 HEX NUT M6-1
11	P0513X2BF011 POINTER
12	P0513X2BF012 STEP SCREW M4-.7 X 5
13	P0513X2BF013 HINGE SHAFT
14	P0513X2BF014 ROLL PIN 5 X 35
15	P0513X2BF015 UPPER WHEEL SHAFT HINGE
16	P0513X2BF016 UPPER WHEEL SHAFT
17	P0513X2BF017 UPPER WHEEL ASSEMBLY
17-1	P0513X2BF017-1 BUSHING
17-2	P0513X2BF017-2 BALL BEARING 6204-2RS
17-3	P0513X2BF017-3 INT RETAINING RING 47MM
17-4	P0513X2BF017-4 UPPER WHEEL 17"
17-5	P0513X2BF017-5 URETHANE TIRE 17" 1-PAIR
18	P0513X2BF018 LOWER WHEEL ASSEMBLY
18-1	P0513X2BF018-1 BUSHING
18-2	P0513X2BF018-2 BALL BEARING 6204-2RS
18-3	P0513X2BF018-3 INT RETAINING RING 47MM
18-4	P0513X2BF018-4 LOWER WHEEL 17"
18-5	P0513X2BF018-5 URETHANE TIRE 17" 1-PAIR
19	P0513X2BF019 MAG SWITCH ASSY SDE MPE-18 220V
19-1	P0513X2BF019-1 CONTACTOR SDE MA-18 220V
19-2	P0513X2BF019-2 OL RELAY SDE RA-20 8-12A
19-3	P0513X2BF019-3 MAG SWITCH COVER ASSEMBLY
19-4	P0513X2BF019-4 CONTROL CORD 16G 5W V2.05.11
19-5	P0513X2BF019-5 MOTOR CORD 14G 5W
19-6	P0513X2BF019-6 PHLP HD SCR M5-.8 X 10
21	P0513X2BF021 WHEEL FLAT WASHER 8MM
22	P0513X2BF022 CAP SCREW M8-1.25 X 16
23	P0513X2BF023 SAW BLADE 131.5" X 1/2" 6TPI HOOK
24	P0513X2BF024 LOCK WASHER 8MM
25	P0513X2BF025 CAP SCREW M8-1.25 X 20
28	P0513X2BF028 WHEEL PULLEY/BRAKE DRUM
29	P0513X2BF029 HEX NUT 1-14
30	P0513X2BF030 LOCK WASHER 1"
31	P0513X2BF031 CONTROL PANEL PLATE
32	P0513X2BF032 COMPRESSION SPRING 7 X 8 X 90
33	P0513X2BF033 ROLL PIN 3 X 16
34	P0513X2BF034 ALIGNMENT PLATE
35	P0513X2BF035 THRUST BEARING 51201
36	P0513X2BF036 TAP SCREW M4 X 10
37	P0513X2BF037 TENSION HANDWHEEL
38	P0513X2BF038 TENSION ADJUSTING ROD
39	P0513X2BF039 FLANGE SCREW M5-.8 X 10
40	P0513X2BF040 STOP BUTTON
41	P0513X2BF041 START BUTTON
44	P0513X2BF044 CAP SCREW M8-1.25 X 16
45	P0513X2BF045 FENDER WASHER 8MM

REF PART #	DESCRIPTION
46	P0513X2BF046 UPPER WHEEL SLIDING BRACKET
47	P0513X2BF047 CAP SCREW M6-1 X 25
48	P0513X2BF048 STEEL BLIND RIVET 3 X 13MM
49	P0513X2BF049 CAP SCREW M6-1 X 10
50	P0513X2BF050 CLEAR WINDOW
51	P0513X2BF051 KEY SWITCH
55A	P0513X2BF055A UPPER WHEEL COVER ASSY
55	P0513X2BF055 UPPER WHEEL COVER
56	P0513X2BF056 HEX BOLT M6-1 X 25
57	P0513X2BF057 FLAT WASHER 6MM
58	P0513X2BF058 WHEEL BRUSH
59	P0513X2BF059 CAP SCREW M6-1 X 25
60	P0513X2BF060 STAR KNOB
61	P0513X2BF061 LOCK NUT M6-1
62	P0513X2BF062 STRAIN RELIEF 16MM STRAIGHT LT
63	P0513X2BF063 HEIGHT POINTER
64	P0513X2BF064 HEX NUT M8-1.25
65	P0513X2BF065 HEX BOLT M8-1.25 X 90
66	P0513X2BF066 STAR KNOB BOLT M10-1.5 X 20
67	P0513X2BF067 STAR KNOB BOLT M10-1.5 X 53
68	P0513X2BF068 THREADED HANDLE M10-1.5
69	P0513X2BF069 CAM
70	P0513X2BF070 PILLOW BLOCK
71	P0513X2BF071 HANDLE M12-1.75
72	P0513X2BF072 LEVER
73	P0513X2BF073 HEX NUT M12-1.75
74	P0513X2BF074 LEVER HUB
75	P0513X2BF075 BUTTON HD CAP SCR M8-1.25 X 20
76	P0513X2BF076 LOCK WASHER 8MM
78	P0513X2BF078 SHAFT COVER
79	P0513X2BF079 SET SCREW M8-1.25 X 20
80	P0513X2BF080 HEX NUT M8-1.25
81	P0513X2BF081 LOWER WHEEL SHAFT
82	P0513X2BF082 MOTOR 2HP 220V 1-PH W/BRAKE
82-2	P0513X2BF082-2 MOTOR FAN COVER
82-3	P0513X2BF082-3 MOTOR FAN
82-4	P0513X2BF082-4 CAPACITOR COVER
82-5	P0513X2BF082-5 R CAPACITOR 45M 450V 2 X 2-1/2
82-6	P0513X2BF082-6 MOTOR JUNCTION BOX
82-9	P0513X2BF082-9 MAGNETIC BRAKE YZG
82-10	P0513X2BF082-10 BRAKE SHOE
82-14	P0513X2BF082-14 BALL BEARING 6205ZZ
82-15	P0513X2BF082-15 BALL BEARING 6203ZZ
83	P0513X2BF083 HEX BOLT M10-1.5 X 25
84	P0513X2BF084 LOCK WASHER 10MM
85	P0513X2BF085 MOTOR MOUNT BRACKET
86	P0513X2BF086 BUTTON HD CAP SCR M8-1.25 X 20
87	P0513X2BF087 STRAIN RELIEF PLATE 1-HOLE
88	P0513X2BF088 TAP SCREW M4 X 10
89	P0513X2BF089 PILLOW BLOCK
90	P0513X2BF090 KEY 5 X 5 X 35
91	P0513X2BF091 HEX BOLT M8-1.25 X 20 LH
92	P0513X2BF092 MOTOR PULLEY TYPE-A 3.5"



G0513X2BF Main Parts List

REF	PART #	DESCRIPTION
93	P0513X2BF093	V-BELT A42
94	P0513X2BF094	CAP SCREW M6-1 X 10
95	P0513X2BF095	LOWER WHEEL COVER
97	P0513X2BF097	FENDER WASHER 8MM
111	P0513X2BF111	CAP SCREW M6-1 X 20
119	P0513X2BF119	LOCK WASHER 8MM
171	P0513X2BF171	FLANGE SCREW M5-.8 X 10

REF	PART #	DESCRIPTION
172	P0513X2BF172	CORD CLIP 5/16"
173	P0513X2BF173	FLANGE SCREW M5-.8 X 50
174	P0513X2BF174	PHLP HD SCR M4-.7 X 10
175	P0513X2BF175	EXT TOOTH WASHER 5MM
177	P0513X2BF177	JUNCTION BOX
178	P0513X2BF178	WIRE NUT 14-22G

G0513X2BF Labels

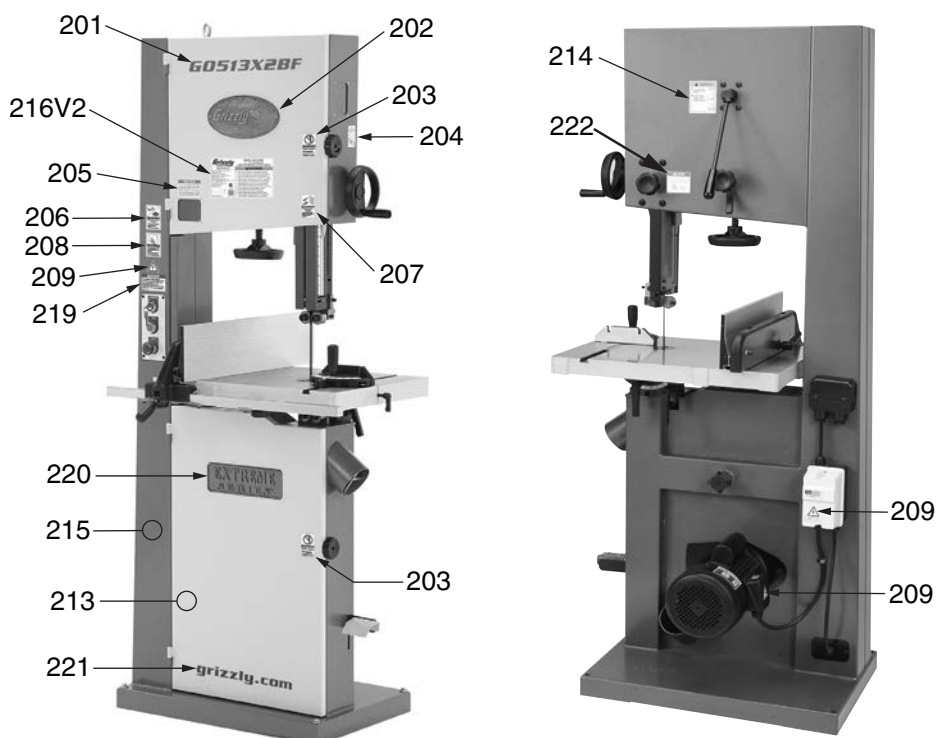

REF	PART #	DESCRIPTION
201	P0513X2BF201	MODEL NUMBER LABEL
202	P0513X2BF202	NAMEPLATE-LARGE
203	P0513X2BF203	DON'T OPEN DOOR LABEL
204	P0513X2BF204	GUARD ADJUSTMENT LABEL
205	P0513X2BF205	SCALE DIRECTIONS LABEL
206	P0513X2BF206	GLASSES/RESPIRATOR LABEL
207	P0513X2BF207	DISCONNECT POWER LABEL
208	P0513X2BF208	READ MANUAL LABEL
209	P0513X2BF209	ELECTRICITY LABEL

REF	PART #	DESCRIPTION
213	P0513X2BF213	TOUCH-UP PAINT, GRIZZLY PUTTY
214	P0513X2BF214	TENSION ADJ LABEL
215	P0513X2BF215	TOUCH-UP PAINT, GRIZZLY GREEN
216V2	P0513X2BF216V2	MACHINE ID LABEL V2.10.18
219	P0513X2BF219	MAGNETIC BRAKE LABEL
220	P0513X2BF220	EXTREME SERIES PLATE
221	P0513X2BF221	GRIZZLY.COM LABEL
222	P0513X2BF222	GUIDE POST LOCK LABEL

WARNING

Safety labels help reduce the risk of serious injury caused by machine hazards. If any label comes off or becomes unreadable, the owner of this machine **MUST** replace it in the original location before resuming operations. For replacements, contact (800) 523-4777 or www.grizzly.com.



G0513X2F Main Parts List

REF	PART #	DESCRIPTION
2	P0513X2F002	SET SCREW M6-1 X 10
3	P0513X2F003	BUSHING
4	P0513X2F004	LIFTING EYE BOLT M10-1.5
5	P0513X2F005	MACHINE BODY
7	P0513X2F007	BUSHING
8	P0513X2F008	FLAT WASHER 6MM
10	P0513X2F010	HEX NUT M6-1
11	P0513X2F011	POINTER
12	P0513X2F012	STEP SCREW M4-.7 X 5
13	P0513X2F013	HINGE SHAFT
14	P0513X2F014	ROLL PIN 5 X 36
15	P0513X2F015	UPPER WHEEL SHAFT HINGE
16	P0513X2F016	UPPER WHEEL SHAFT
17	P0513X2F017	UPPER WHEEL ASSEMBLY
17-1	P0513X2F017-1	BUSHING
17-2	P0513X2F017-2	BALL BEARING 6204-2RS
17-3	P0513X2F017-3	INT RETAINING RING 47MM
17-4	P0513X2F017-4	UPPER WHEEL 17"
17-5	P0513X2F017-5	URETHANE TIRE 17" 1-PAIR
18	P0513X2F018	LOWER WHEEL ASSEMBLY
18-1	P0513X2F018-1	BUSHING
18-2	P0513X2F018-2	BALL BEARING 6204-2RS
18-3	P0513X2F018-3	INT RETAINING RING 47MM
18-4	P0513X2F018-4	LOWER WHEEL 17"
18-5	P0513X2F018-5	URETHANE TIRE, 1-PAIR
21	P0513X2F021	WHEEL FLAT WASHER 8MM
22	P0513X2F022	CAP SCREW M8-1.25 X 16
23	P0513X2F023	SAW BLADE 131.5" X 1/2" 6TPI HOOK
24	P0513X2F024	LOCK WASHER 8MM
25	P0513X2F025	CAP SCREW M8-1.25 X 20
28	P0513X2F028	WHEEL PULLEY/BRAKE DRUM
29	P0513X2F029	HEX NUT 1-14
30	P0513X2F030	LOCK WASHER 1"
32	P0513X2F032	COMPRESSION SPRING 7 X 8 X 90
33	P0513X2F033	ROLL PIN 3 X 16
34	P0513X2F034	ALIGNMENT PLATE
35	P0513X2F035	THRUST BEARING 51201
37	P0513X2F037	TENSION HANDWHEEL
38	P0513X2F038	TENSION ADJUSTING ROD
39	P0513X2F039	FLANGE SCREW M5-.8 X 10
43	P0513X2F043	CONTROL PANEL PLATE
44	P0513X2F044	CAP SCREW M8-1.25 X 16
45	P0513X2F045	FENDER WASHER 8MM
46	P0513X2F046	UPPER WHEEL SLIDING BRACKET
47	P0513X2F047	CAP SCREW M8-1.25 X 50
48	P0513X2F048	STEEL BLIND RIVET 3 X 13MM
49	P0513X2F049	CAP SCREW M6-1 X 10
50	P0513X2F050	CLEAR WINDOW
55A	P0513X2F055A	UPPER WHEEL COVER ASSY
55	P0513X2F055	UPPER WHEEL COVER
56	P0513X2F056	HEX BOLT M6-1 X 25
57	P0513X2F057	FLAT WASHER 6MM
58	P0513X2F058	WHEEL BRUSH

REF	PART #	DESCRIPTION
59	P0513X2F059	CAP SCREW M6-1 X 25
60	P0513X2F060	STAR KNOB
61	P0513X2F061	LOCK NUT M6-1
62	P0513X2F062	STRAIN RELIEF 16MM STRAIGHT LT
63	P0513X2F063	HEIGHT POINTER
64	P0513X2F064	HEX NUT M8-1.25
65	P0513X2F065	HEX BOLT M8-1.25 X 90
66	P0513X2F066	STAR KNOB BOLT M10-1.5 X 20
67	P0513X2F067	STAR KNOB BOLT M10-1.5 X 55
68	P0513X2F068	THREADED HANDLE M10-1.5
69	P0513X2F069	CAM
70	P0513X2F070	PILLOW BLOCK
71	P0513X2F071	HANDLE M12-1.75
72	P0513X2F072	LEVER
73	P0513X2F073	HEX NUT M12-1.75
74	P0513X2F074	LEVER HUB
75	P0513X2F075	BUTTON HD CAP SCR M8-125 X 20
76	P0513X2F076	LOCK WASHER 8MM
78	P0513X2F078	SHAFT COVER
79	P0513X2F079	SET SCREW M8-1.25 X 20
80	P0513X2F080	HEX NUT M8-1.25
81	P0513X2F081	LOWER WHEEL SHAFT
82	P0513X2F082	MOTOR 2HP 110V/220V 1-PH
82-1	P0513X2F082-1	MOTOR FAN COVER
82-2	P0513X2F082-2	MOTOR FAN
82-3	P0513X2F082-3	CAPACITOR COVER
82-4	P0513X2F082-4	R CAPACITOR 40M 250V 1-3/8 X 2-5/8
82-5	P0513X2F082-5	MOTOR JUNCTION BOX
82-6	P0513X2F082-6	S CAPACITOR 300M 250V 1-1/2 X 2-3/8
82-7	P0513X2F082-7	CONTACT PLATE 5/8
82-8A	P0513X2F082-8A	CENTRIFUGAL SWITH W/CONT PLATE
82-8	P0513X2F082-8	CENTRIFUGAL SWITCH 5/8-1725
82-9	P0513X2F082-9	BALL BEARING 6205ZZ
82-10	P0513X2F082-10	BALL BEARING 6203ZZ
83	P0513X2F083	HEX BOLT M10-1.5 X 25
84	P0513X2F084	LOCK WASHER 10MM
85	P0513X2F085	MOTOR MOUNT BRACKET
86	P0513X2F086	BUTTON HD CAP SCR M8-125 X 20
87	P0513X2F087	STRAIN RELIEF PLATE 1-HOLE
88	P0513X2F088	FLANGE SCREW M5-.8 X 10
89	P0513X2F089	PILLOW BLOCK
90	P0513X2F090	KEY 5 X 5 X 35
91	P0513X2F091	HEX BOLT M8-1.25 X 20 LH
92	P0513X2F092	MOTOR PULLEY TYPE-A 3.5"
93	P0513X2F093	V-BELT A42
94	P0513X2F094	CAP SCREW M6-1 X 10
95	P0513X2F095	LOWER WHEEL COVER
97	P0513X2F097	FENDER WASHER 8MM
111	P0513X2F111	CAP SCREW M6-1 X 20
119	P0513X2F119	FLAT WASHER 4MM
188	P0513X2F188	FLANGE SCREW M5-.8 X 10
189	P0513X2F189	CORD CLIP 5/16"
190	P0513X2F190	TAP SCREW M4 X 10



G0513X2F Main Parts List

REF	PART #	DESCRIPTION
193	P0513X2F193	KEY SWITCH
194	P0513X2F194	START BUTTON
195	P0513X2F195	STOP BUTTON
196	P0513X2F196	FLANGE SCREW M5-.8 X 50
197	P0513X2F197	JUNCTION BOX
198	P0513X2F198	WIRE NUT 14-22G
199	P0513X2F199	EXT TOOTH WASHER 5MM
200	P0513X2F200	PHLP HD SCR M4-.7 X 10
242	P0513X2F242	MAG SWITCH ASSY 220V MPE-09
242-1	P0513X2F242-1	CONTACTOR SDE MA-09 220-240V

REF	PART #	DESCRIPTION
242-2	P0513X2F242-2	OL RELAY SDE RA-20 8-12A
242-3	P0513X2F242-3	MAG SWITCH COVER ASSEMBLY
242-4	P0513X2F242-4	CONTROL CORD 16G 3W
242-5	P0513X2F242-5	MOTOR CORD 14G 3W
243	P0513X2F243	PHLP HD SCR M5-.8 X 10
244	P0513X2F244	MAG SWITCH ASSY 110V MPE-18
244-1	P0513X2F244-1	CONTACTOR SDE MA-18 110V
244-2	P0513X2F244-2	OL RELAY SDE RA-30 18-26A
244-3	P0513X2F244-3	MAG SWITCH COVER ASSEMBLY

G0513X2F Labels

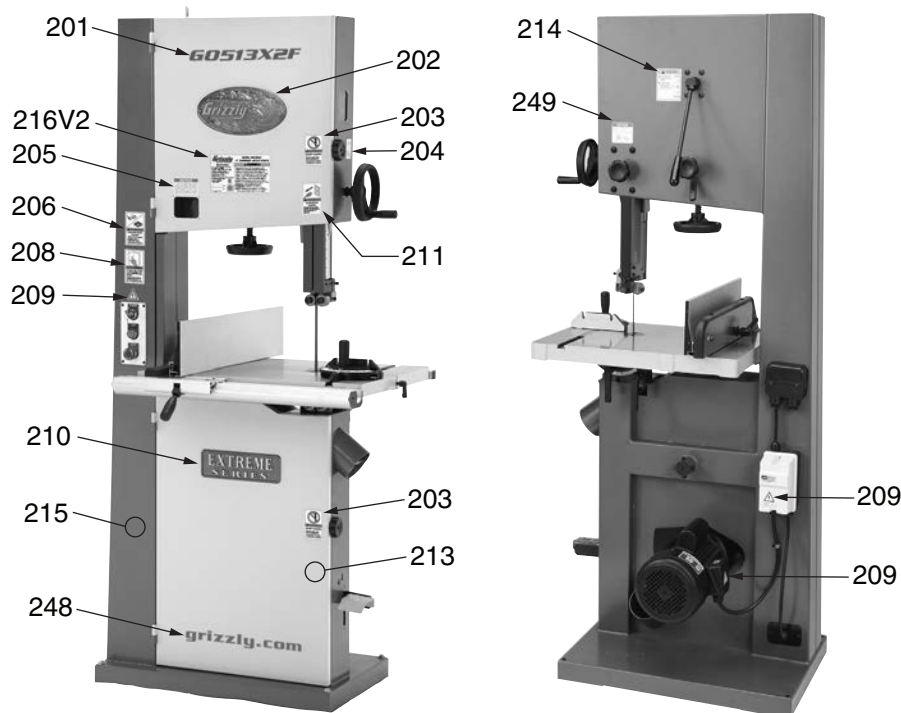

REF	PART #	DESCRIPTION
201	P0513X2F201	MODEL NUMBER LABEL
202	P0513X2F202	GRIZZLY NAMEPLATE- LARGE
203	P0513X2F203	DON'T OPEN DOOR LABEL
204	P0513X2F204	GUARD ADJUSTMENT LABEL
205	P0513X2F205	SCALE DIRECTIONS LABEL
206	P0513X2F206	GLASSES/RESPIRATOR LABEL
208	P0513X2F208	READ MANUAL LABEL
209	P0513X2F209	ELECTRICITY LABEL

REF	PART #	DESCRIPTION
210	P0513X2F210	EXTREME SERIES NAMEPLATE
211	P0513X2F211	DISCONNECT POWER LABEL
213	P0513X2F213	TOUCH-UP PAINT, GRIZZLY PUTTY
214	P0513X2F214	TENSION ADJUSTMENT LABEL
215	P0513X2F215	TOUCH-UP PAINT, GRIZZLY GREEN
216V2	P0513X2F216V2	MACHINE ID LABEL V2.10.18
248	P0513X2F248	GRIZZLY.COM LABEL
249	P0513X2F249	GUIDEPOST LOCK LABEL

WARNING

Safety labels help reduce the risk of serious injury caused by machine hazards. If any label comes off or becomes unreadable, the owner of this machine **MUST** replace it in the original location before resuming operations. For replacements, contact (800) 523-4777 or www.grizzly.com.



G0513X2, G0513X2B, G0513X2BF & G0513X2F Guides & Trunnions

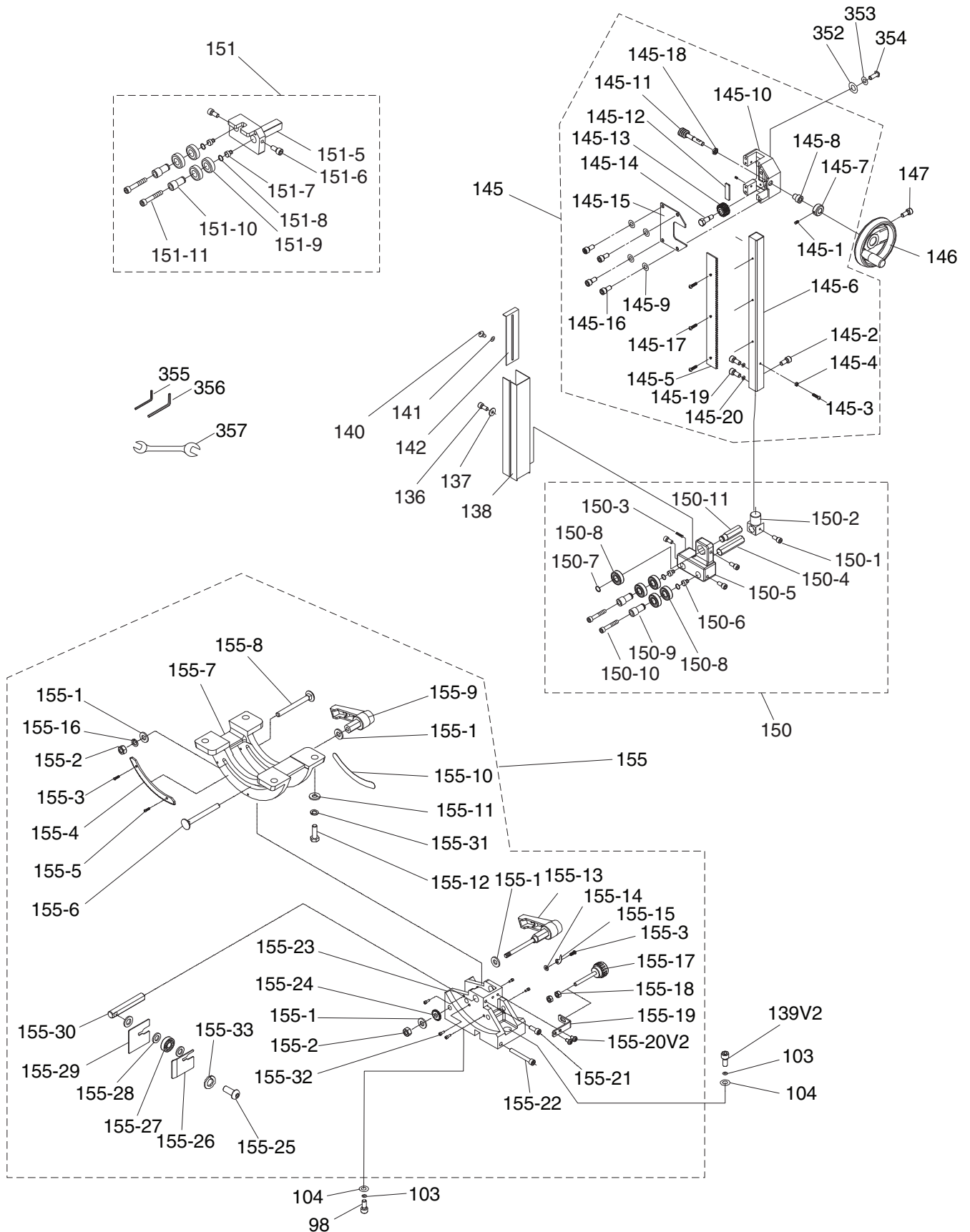

G0513X2, G0513X2B, G0513X2BF & G0513X2F Guides & Trunnions Parts List

REF	PART #	DESCRIPTION
98	P0513X2098	CAP SCREW M10-1.5 X 35
103	P0513X2103	LOCK WASHER 10MM
104	P0513X2104	FLAT WASHER 10MM
136	P0513X2136	CAP SCREW M5-.8 X 10
137	P0513X2137	FLAT WASHER 5MM
138	P0513X2138	UPPER BLADE GUARD
139V2	P0513X2139V2	CAP SCREW M10-1.5 X 35
140	P0513X2140	STEP SCREW M4-.7 X 5
141	P0513X2141	FIBER WASHER 5MM
142	P0513X2142	SLIDING PLATE
145	P0513X2145	GUIDE POST ASSEMBLY
145-1	P0513X2145-1	SET SCREW M5-.8 X 5
145-2	P0513X2145-2	CAP SCREW M6-1 X 16
145-3	P0513X2145-3	PHLP HD SCR M4-.7 X 10
145-4	P0513X2145-4	HEX NUT M4-.7
145-5	P0513X2145-5	RACK
145-6	P0513X2145-6	GUIDE POST
145-7	P0513X2145-7	LOCK COLLAR
145-8	P0513X2145-8	THREADED BUSHING V2.06.09
145-9	P0513X2145-9	LOCK WASHER 8MM
145-10	P0513X2145-10	THREADED GUIDE BRACKET 14MM V2.06.09
145-11	P0513X2145-11	WORM CYLINDER
145-12	P0513X2145-12	FIXED PLATE
145-13	P0513X2145-13	PINION GEAR 15T
145-14	P0513X2145-14	PINION GEAR STEP BOLT
145-15	P0513X2145-15	BRACKET COVER
145-16	P0513X2145-16	CAP SCREW M8-1.25 X 16
145-17	P0513X2145-17	FLAT HD SCR M4-.7 X 8
145-18	P0513X2145-18	BUSHING
145-19	P0513X2145-19	CAP SCREW M5-.8 X 12
145-20	P0513X2145-20	FLAT WASHER 5MM
146	P0513X2146	GUIDE POST HANDWHEEL
147	P0513X2147	CAP SCREW M6-1 X 20
150	P0513X2150	UPPER BLADE GUIDE ASSEMBLY
150-1	P0513X2150-1	CAP SCREW M6-1 X 16
150-2	P0513X2150-2	UPPER GUIDE SUPPORT BLOCK
150-3	P0513X2150-3	SET SCREW M6-1 X 10
150-4	P0513X2150-4	ADJUSTMENT BAR
150-5	P0513X2150-5	UPPER BLADE GUIDE SUPPORT
150-6	P0513X2150-6	ECCENTRIC SHAFT
150-7	P0513X2150-7	EXT RETAINING RING 15MM
150-8	P0513X2150-8	BALL BEARING 6202ZZ
150-9	P0513X2150-9	HANDLE BUSHING
150-10	P0513X2150-10	CAP SCREW M6-1 X 35
150-11	P0513X2150-11	UPPER SPACING SHAFT
151	P0513X2151	LOWER BLADE GUIDE ASSEMBLY
151-5	P0513X2151-5	LOWER BLADE GUIDE SUPPORT

REF	PART #	DESCRIPTION
151-6	P0513X2151-6	CAP SCREW M6-1 X 16
151-7	P0513X2151-7	ECCENTRIC SHAFT
151-8	P0513X2151-8	EXT RETAINING RING 15MM
151-9	P0513X2151-9	BALL BEARING 6202ZZ
151-10	P0513X2151-10	HANDLE BUSHING
151-11	P0513X2151-11	CAP SCREW M6-1 X 35
155	P0513X2155	CAST IRON TRUNNION ASSEMBLY
155-1	P0513X2155-1	FLAT WASHER 8MM
155-2	P0513X2155-2	LOCK NUT M8-1.25
155-3	P0513X2155-3	PHLP HD SCR M4-.7 x 6
155-4	P0513X2155-4	GEAR PLATE
155-5	P0513X2155-5	FLAT HD SCR M4-.7 X 6
155-6	P0513X2155-6	CARRIAGE BOLT M8-1.25 X 85
155-7	P0513X2155-7	CAST IRON TRUNNION
155-8	P0513X2155-8	CARRIAGE BOLT M8-1.25 X 80
155-9	P0513X2155-9	LOCK HANDLE M8-1.25
155-10	P0513X2155-10	TABLE TILT SCALE
155-11	P0513X2155-11	FLAT WASHER 8MM
155-12	P0513X2155-12	HEX BOLT M8-1.25 X 25
155-13	P0513X2155-13	LOCK HANDLE M8-1.25
155-14	P0513X2155-14	FLAT WASHER 4MM
155-15	P0513X2155-15	POINTER
155-16	P0513X2155-16	LOCK WASHER 8MM
155-17	P0513X2155-17	ADJUSTMENT KNOB BOLT M6-1
155-18	P0513X2155-18	HEX NUT M6-1
155-19	P0513X2155-19	L-BRACKET
155-20V2	P0513X2155-20V2	FLAT HD SCR M5-.8 X 8
155-21	P0513X2155-21	CAP SCREW M6-1 X 16
155-22	P0513X2155-22	CAP SCREW M6-1 X 50
155-23	P0513X2155-23	TRUNNION SUPPORT BRACKET
155-24	P0513X2155-24	TRUNNION GEAR
155-25	P0513X2155-25	BUTTON HD CAP SCR M10-1.5 X 30
155-26	P0513X2155-26	RIGHT GUARD
155-27	P0513X2155-27	BALL BEARING 6000ZZ
155-28	P0513X2155-28	FLAT WASHER 10MM
155-29	P0513X2155-29	LEFT GUARD
155-30	P0513X2155-30	ADJUSTMENT ROD
155-31	P0513X2155-31	LOCK WASHER 8MM
155-32	P0513X2155-32	CAP SCREW M5-.8 X 6
155-33	P0513X2155-33	LOCK WASHER 10MM
352	P0513X2352	FLAT WASHER 8MM
353	P0513X2353	LOCK WASHER 8MM
354	P0513X2354	BUTTON HD CAP SCR M8-1.25 X 20
355	P0513X2355	HEX WRENCH 5MM
356	P0513X2356	HEX WRENCH 8MM
357	P0513X2357	WRENCH 10 X 13 OPEN-END

BUY PARTS ONLINE AT GRIZZLY.COM!
Scan QR code to visit our Parts Store.



G0513X2 & G0513X2F Fence Assembly & Table

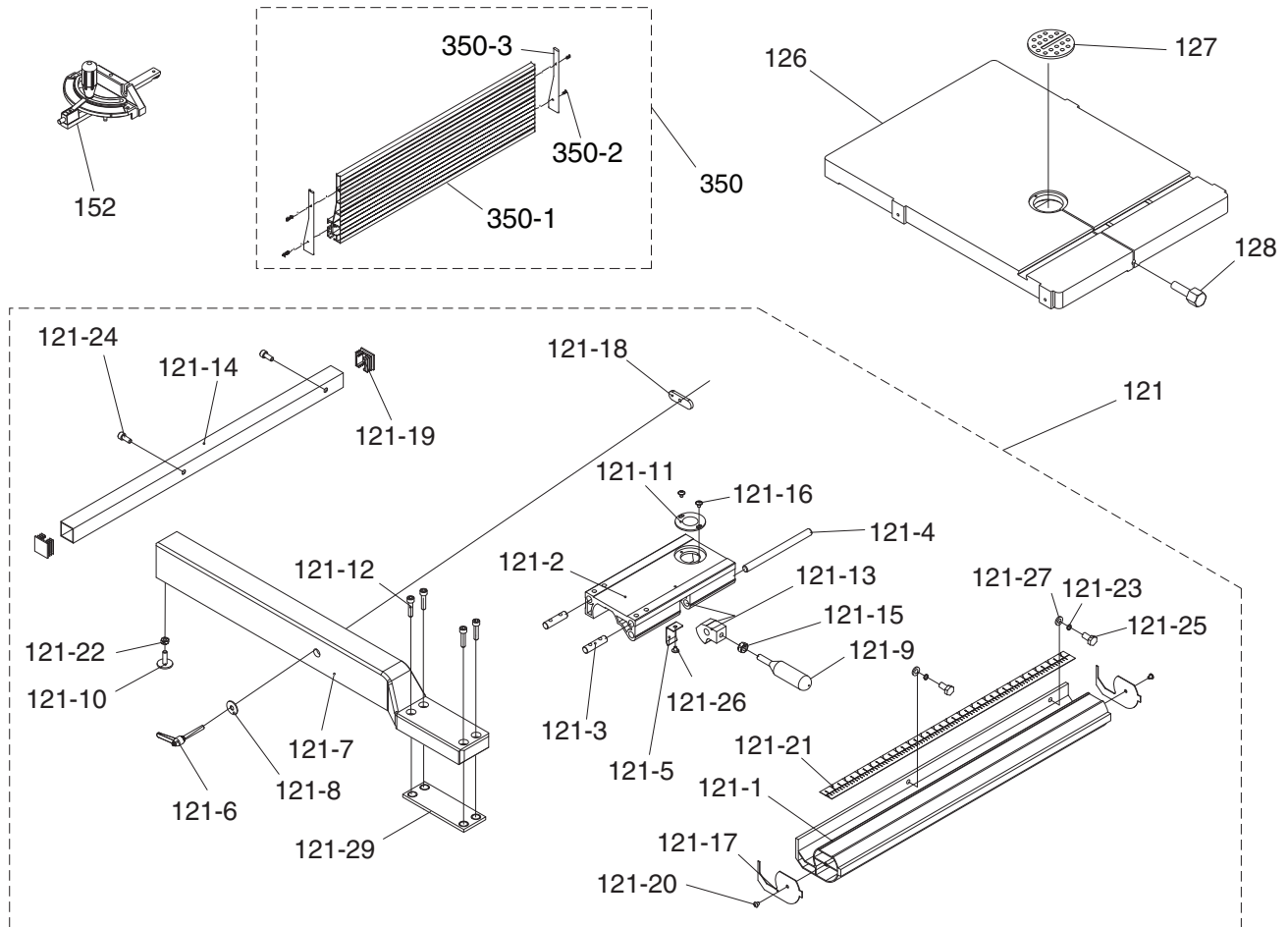

REF	PART #	DESCRIPTION
121	P0513X2121	FENCE ASSEMBLY
121-1	P0513X2121-1	FRONT RAIL 640MM
121-2	P0513X2121-2	ADJUST BASE
121-3	P0513X2121-3	FIXED SHAFT
121-4	P0513X2121-4	SHAFT
121-5	P0513X2121-5	SPRING PIECE
121-6	P0513X2121-6	LOCKING HANDLE M8-1.25 X 44
121-7	P0513X2121-7	CAST IRON FENCE 590MM
121-8	P0513X2121-8	FLAT WASHER 8MM
121-9	P0513X2121-9	FENCE HANDLE M8-1.25 X 22
121-10	P0513X2121-10	RAIL PAD
121-11	P0513X2121-11	CONVEX WINDOW
121-12	P0513X2121-12	CAP SCREW M6-1 X 24
121-13	P0513X2121-13	LOCK BLOCK
121-14	P0513X2121-14	REAR RAIL 640MM
121-15	P0513X2121-15	HEX NUT M8-1.25
121-16	P0513X2121-16	FLANGE SCREW M4-.7 X 6
121-17	P0513X2121-17	GUARD PIECE
121-18	P0513X2121-18	MOVING PLATE

REF	PART #	DESCRIPTION
121-19	P0513X2121-19	PLUG
121-20	P0513X2121-20	TAP SCREW M3.5 X 8
121-21	P0513X2121-21	FENCE SCALE 18-1/2"
121-22	P0513X2121-22	HEX NUT M6-1
121-23	P0513X2121-23	LOCK WASHER 6MM
121-24	P0513X2121-24	CAP SCREW M6-1 X 16
121-25	P0513X2121-25	HEX BOLT M6-1 X 20
121-26	P0513X2121-26	FLANGE BOLT M4-.7 X 8
121-27	P0513X2121-27	FLAT WASHER 6MM
121-29	P0513X2121-29	SPACER PLATE
126	P0513X2126	TABLE 17" X 24"
127	P0513X2127	TABLE INSERT
128	P0513X2128	TABLE PIN
152	P0513X2152	MITER GAUGE ASSY
350	P0513X2350	RESAW FENCE ASSEMBLY
350-1	P0513X2350-1	ALUMINUM RESAW FENCE 590MM
350-2	P0513X2350-2	TAP SCREW 3.5 X 8
350-3	P0513X2350-3	FENCE END PLATE 148 X 22 X 1



G0513X2B & G0513X2BF Fence Assembly & Table

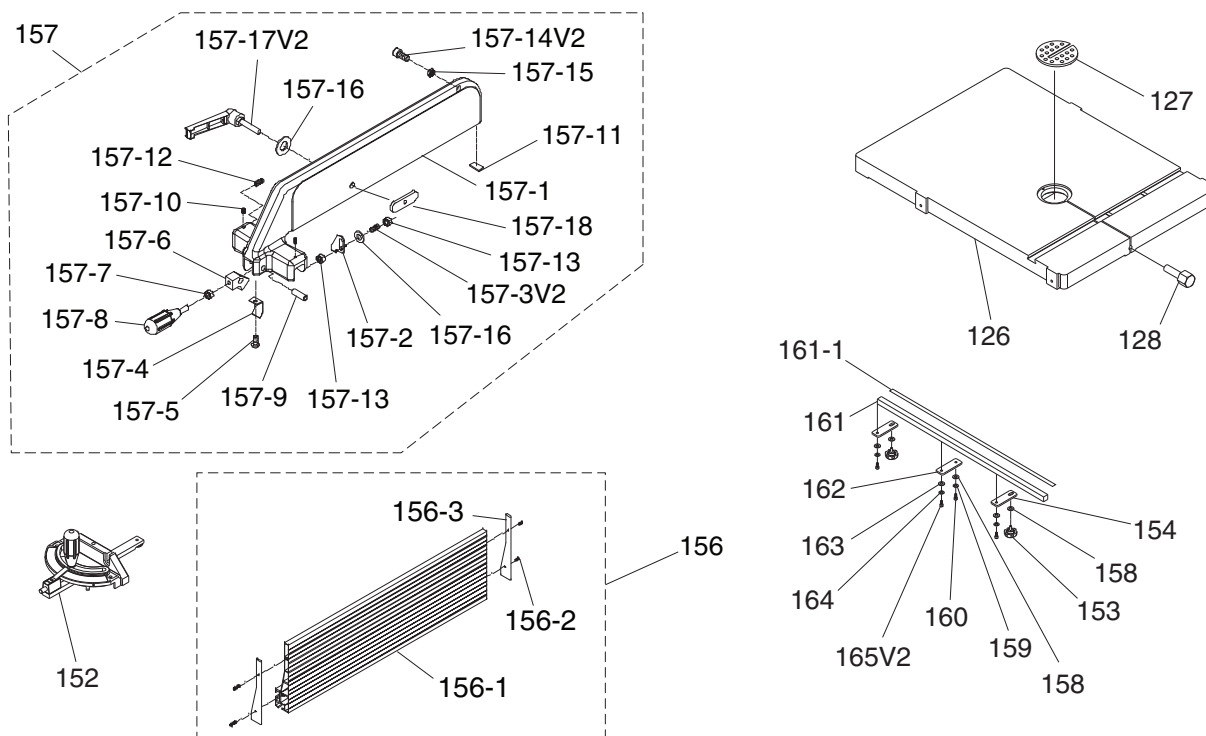

REF	PART #	DESCRIPTION
126	P0513X2B126	TABLE 17" X 24"
127	P0513X2B127	TABLE INSERT
128	P0513X2B128	TABLE PIN
152	P0513X2B152	MITER GAUGE ASSY
153	P0513X2B153	KNOB SCREW M8-1.25 X 20
154	P0513X2B154	OUTER RAIL PLATE
156	P0513X2B156	RESAW FENCE ASSEMBLY
156-1	P0513X2B156-1	ALUMINUM RESAW FENCE 590MM
156-2	P0513X2B156-2	TAP SCREW 3.5 X 8
156-3	P0513X2B156-3	FENCE END PLATE 148 X 22 X 1
157	P0513X2B157	FENCE ASSEMBLY
157-1	P0513X2B157-1	FENCE
157-2	P0513X2B157-2	POINTER
157-3V2	P0513X2B157-3V2	SET SCREW M8-1.25 X 25
157-4	P0513X2B157-4	SPRING PIECE
157-5	P0513X2B157-5	FLANGE SCREW M4-.7 X 8
157-6	P0513X2B157-6	PIVOT BLOCK
157-7	P0513X2B157-7	HEX NUT M8-1.25
157-8	P0513X2B157-8	FENCE LOCK HANDLE

REF	PART #	DESCRIPTION
157-9	P0513X2B157-9	SHAFT
157-10	P0513X2B157-10	PLASTIC SET SCREW M7-1 X 10
157-11	P0513X2B157-11	NYLON PAD
157-12	P0513X2B157-12	SET SCREW M8-1.25 X 12
157-13	P0513X2B157-13	HEX NUT M8-1.25
157-14V2	P0513X2B157-14V2	HEX BOLT M8-1.25 X 20
157-15	P0513X2B157-15	HEX NUT M8-1.25
157-16	P0513X2B157-16	FLAT WASHER 8MM
157-17V2	P0513X2B157-17V2	LOCK HANDLE M8-1.25 X 45 V2.05.11
157-18	P0513X2B157-18	MOVING PLATE
158	P0513X2B158	FLAT WASHER 8MM
159	P0513X2B159	LOCK WASHER 8MM
160	P0513X2B160	CAP SCREW M8-1.25 X 20
161	P0513X2B161	FRONT RAIL
161-1	P0513X2B161-1	FENCE SCALE
162	P0513X2B162	INNER RAIL PLATE
163	P0513X2B163	FLAT WASHER 6MM
164	P0513X2B164	LOCK WASHER 6MM
165V2	P0513X2B165V2	CAP SCREW M6-1 X 20



G0513X2BF & G0513X2F Foot Brake

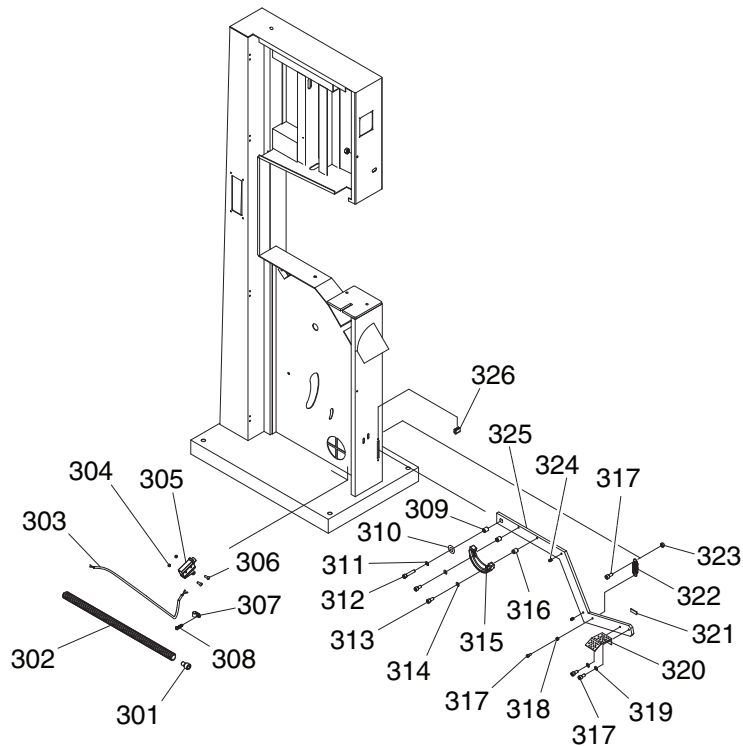

REF	PART #	DESCRIPTION
301	P0513X2F301	CONDUIT GROMMET
302	P0513X2F302	FLEXIBLE CONDUIT 1/2" X 42"
303	P0513X2F303	SWITCH CORD 16G 2W
304	P0513X2F304	HEX NUT 4MM
305	P0513X2F305	BRAKE SWITCH SHINOZAKI AZ7141
306	P0513X2F306	PHLP HD SCR M4-.7 X 30
307	P0513X2F307	CORD CLIP 5/8"
308	P0513X2F308	TAP SCREW M4 X 8
309	P0513X2F309	BUSHING
310	P0513X2F310	FLAT WASHER 8MM
311	P0513X2F311	LOCK WASHER 8MM
312	P0513X2F312	CAP SCREW M8-1.25 X 25
313	P0513X2F313	CAP SCREW M6-1 X 25

REF	PART #	DESCRIPTION
314	P0513X2F314	LOCK WASHER 6MM
315	P0513X2F315	BRAKE SHOE
316	P0513X2F316	BUSHING
317	P0513X2F317	CAP SCREW M6-1 X 16
318	P0513X2F318	HEX NUT M6-1
319	P0513X2F319	LOCK WASHER 6MM
320	P0513X2F320	BRAKE PEDDLE
321	P0513X2F321	NYLON PAD
322	P0513X2F322	BRAKE EXTENSION SPRING
323	P0513X2F323	HEX NUT M6-1
324	P0513X2F324	STEP BOLT M7-1 X 10 W/BUSHING
325	P0513X2F325	BRAKE LEVER
326	P0513X2F326	RUBBER CLIP

