

SECTION 9: PARTS

Main

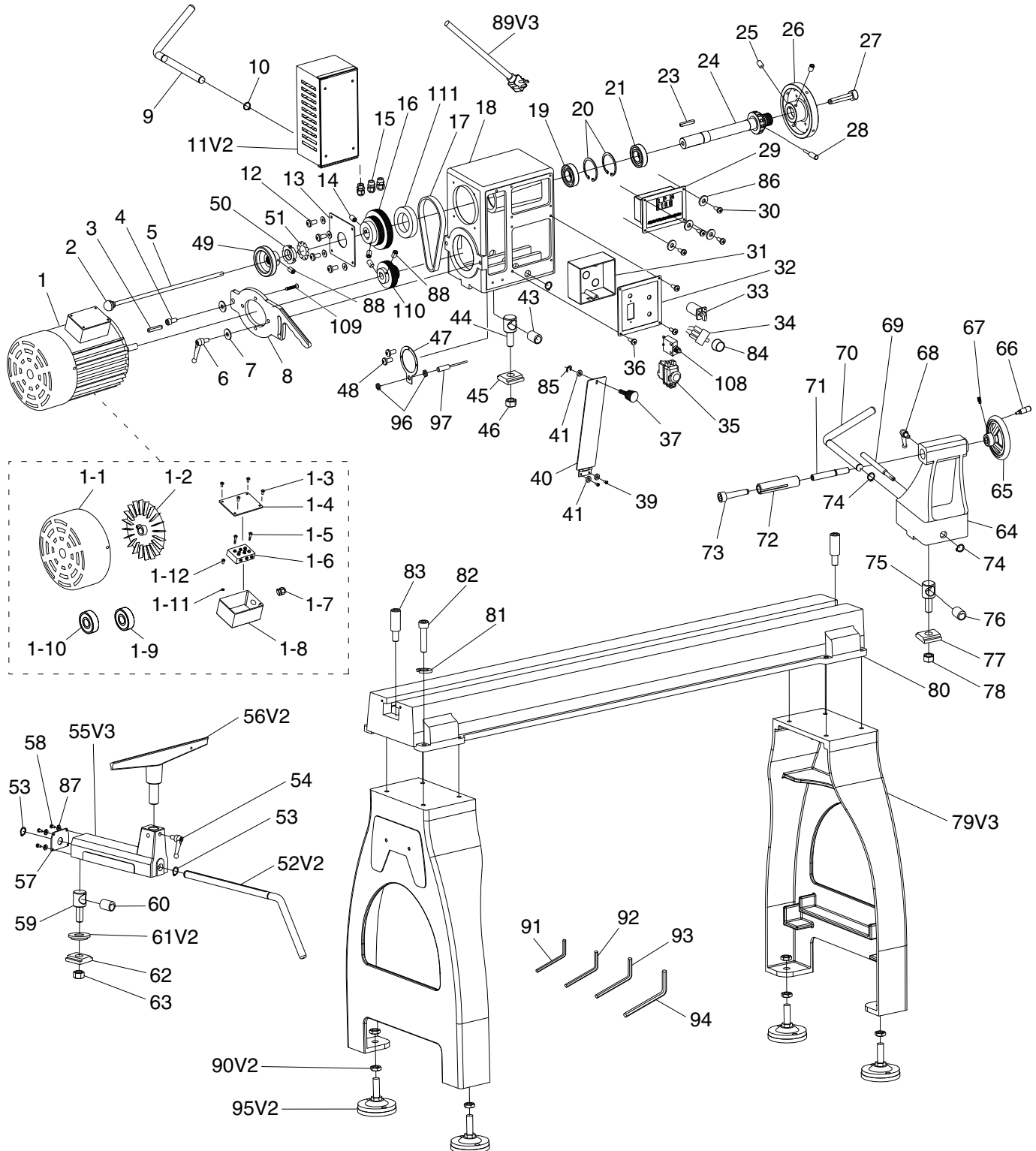

Main Parts List

REF	PART #	DESCRIPTION
1	P0766001	MOTOR 3HP 240V 3-PH
1-1	P0766001-1	MOTOR FAN COVER
1-2	P0766001-2	MOTOR FAN
1-3	P0766001-3	TAP SCREW M4-.7 X 18
1-4	P0766001-4	MOTOR TERMINAL BOX COVER
1-5	P0766001-5	PHLP HD SCR M4-.7 X 20
1-6	P0766001-6	MOTOR TERMINAL
1-7	P0766001-7	STRAIN RELIEF PG13.5 TYPE-3
1-8	P0766001-8	MOTOR TERMINAL BOX
1-9	P0766001-9	BALL BEARING 6205ZZ (FRONT)
1-10	P0766001-10	BALL BEARING 6204ZZ (REAR)
1-11	P0766001-11	FLAT WASHER 4MM
1-12	P0766001-12	PHLP HD SCR M4-.7 X 8
2	P0766002	ROUND KNOB M8-1.25
3	P0766003	KEY 6 X 6 X 60
4	P0766004	CAP SCREW M10-1.5 X 30
5	P0766005	KNOCKOUT ROD M8-1.25 X 14, 369L
6	P0766006	BELT TENSION LOCK LEVER
7	P0766007	FENDER WASHER 10MM
8	P0766008	MOTOR PLATE
9	P0766009	HEADSTOCK LOCK LEVER
10	P0766010	EXT RETAINING RING 19MM
11V2	P0766011V2	INVERTER DELTA VFD11AMS21ANSA V2.05.19
12	P0766012	PHLP HD SCR M5-.8 X 12
13	P0766013	SPINDLE PULLEY COVER
14	P0766014	SET SCREW M8-1.25 X 10
15	P0766015	STRAIN RELIEF PG13.5 TYPE-3
16	P0766016	SPINDLE PULLEY
17	P0766017	V-BELT 220J6
18	P0766018	HEADSTOCK CASTING
19	P0766019	BALL BEARING 6206ZZ
20	P0766020	INT RETAINING RING 62MM
21	P0766021	BALL BEARING 6206ZZ
23	P0766023	KEY 8 X 8 X 45
24	P0766024	SPINDLE
25	P0766025	SET SCREW M6-1 X 12 DOG-PT
26	P0766026	FACEPLATE 153MM DIA
27	P0766027	SPUR CENTER
28	P0766028	INDEXING PIN
29	P0766029	DIGITAL READOUT
30	P0766030	PHLP HD SCR M4-.7 X 8
31	P0766031	SWITCH BOX
32	P0766032	PANEL COVER
33	P0766033	ROTARY SWITCH KEDU ZH-A FOR/OFF/REV
34	P0766034	POTENTIOMETER WX110 B10K
35	P0766035	ON/OFF SWITCH KJD178 250V 18A
36	P0766036	PHLP HD SCR M4-.7 X 6
37	P0766037	KNURLED THUMB SCREW M5-.8 X 8
39	P0766039	PHLP HD SCR M5-.8 X 8
40	P0766040	BELT DOOR
41	P0766041	FLAT WASHER 5MM
43	P0766043	BUSHING
44	P0766044	HEADSTOCK CLAMP BOLT M18-2.5 X 44
45	P0766045	HEADSTOCK CLAMP
46	P0766046	HEX NUT M18-2.5

REF	PART #	DESCRIPTION
47	P0766047	RPM SENSOR BRACKET
48	P0766048	PHLP HD SCR M4-.7 X 8
49	P0766049	HANDWHEEL 49MM DIA DISHED
50	P0766050	SPANNER NUT M30-1.5 LH
51	P0766051	SPANNER NUT WASHER 30MM
52V2	P0766052V2	TOOL REST BASE LOCK LEVER V2.07.15
53	P0766053	EXT RETAINING RING 19MM
54	P0766054	TOOL REST LOCK LEVER
55V3	P0766055V3	TOOL REST BASE (1" BANJO) V3.12.17
56V2	P0766056V2	TOOL REST (1" POST) V2.12.17
57	P0766057	TOOL REST BASE PLATE
58	P0766058	PHLP HD SCR M5-.8 X 12
59	P0766059	TOOL REST CLAMP BOLT M18-2.5 X 44
60	P0766060	ECCENTRIC BUSHING
61V2	P0766061V2	SLIDE BUSHING V2.12.15
62	P0766062	CLAMP PLATE
63	P0766063	HEX NUT M18-2.5
64	P0766064	TAILSTOCK CASTING
65	P0766065	HANDWHEEL 137MM DIA DISHED
66	P0766066	HANDWHEEL HANDLE M8-1.25 X 13, 94L
67	P0766067	SET SCREW M8-1.25 X 12
68	P0766068	QUILL LOCK LEVER
69	P0766069	STOP PIN M8-1.25 X 10, 152L
70	P0766070	TAILSTOCK LOCK LEVER
71	P0766071	LEADSCREW
72	P0766072	QUILL
73	P0766073	LIVE CENTER
74	P0766074	EXT RETAINING RING 19MM
75	P0766075	TAILSTOCK CLAMP BOLT M18-2.5 X 44
76	P0766076	ECCENTRIC BUSHING
77	P0766077	CLAMP PLATE
78	P0766078	HEX NUT M18-2.5
79V3	P0766079V3	LEG V3.01.21
80	P0766080	BED
81	P0766081	LOCK WASHER 10MM
82	P0766082	CAP SCREW M10-1.5 X 35
83	P0766083	BED STOP
84	P0766084	VARIABLE SPEED DIAL
85	P0766085	E-CLIP 5MM
86	P0766086	FLAT WASHER 4MM
87	P0766087	LOCK WASHER 5MM
88	P0766088	SET SCREW M6-1 X 10
89V3	P0766089V3	POWER CORD 12G 3W 72" 6-20P 90-DEG V3
90V2	P0766090V2	HEX NUT M16-2 V2.01.21
91	P0766091	HEX WRENCH 3MM
92	P0766092	HEX WRENCH 4MM
93	P0766093	HEX WRENCH 6MM
94	P0766094	HEX WRENCH 8MM
95V2	P0766095V2	ADJ FOOT M16-2 X 50, 100D V2.01.21
96	P0766096	HEX NUT M12-1.5 THIN
97	P0766097	RPM SENSOR M12-1.5 X 35
108	P0766108	CIRCUIT BREAKER GEN. IND. 220V 15A
109	P0766109	FLAT HD CAP SCR M8-1.25 X 20
110	P0766110	MOTOR PULLEY
111	P0766111	PULLEY SPACER

Please Note: We do our best to stock replacement parts whenever possible, but we cannot guarantee that all parts shown here are available for purchase. Call (800) 523-4777 or visit our online parts store at www.grizzly.com to check for availability.



Labels & Cosmetics

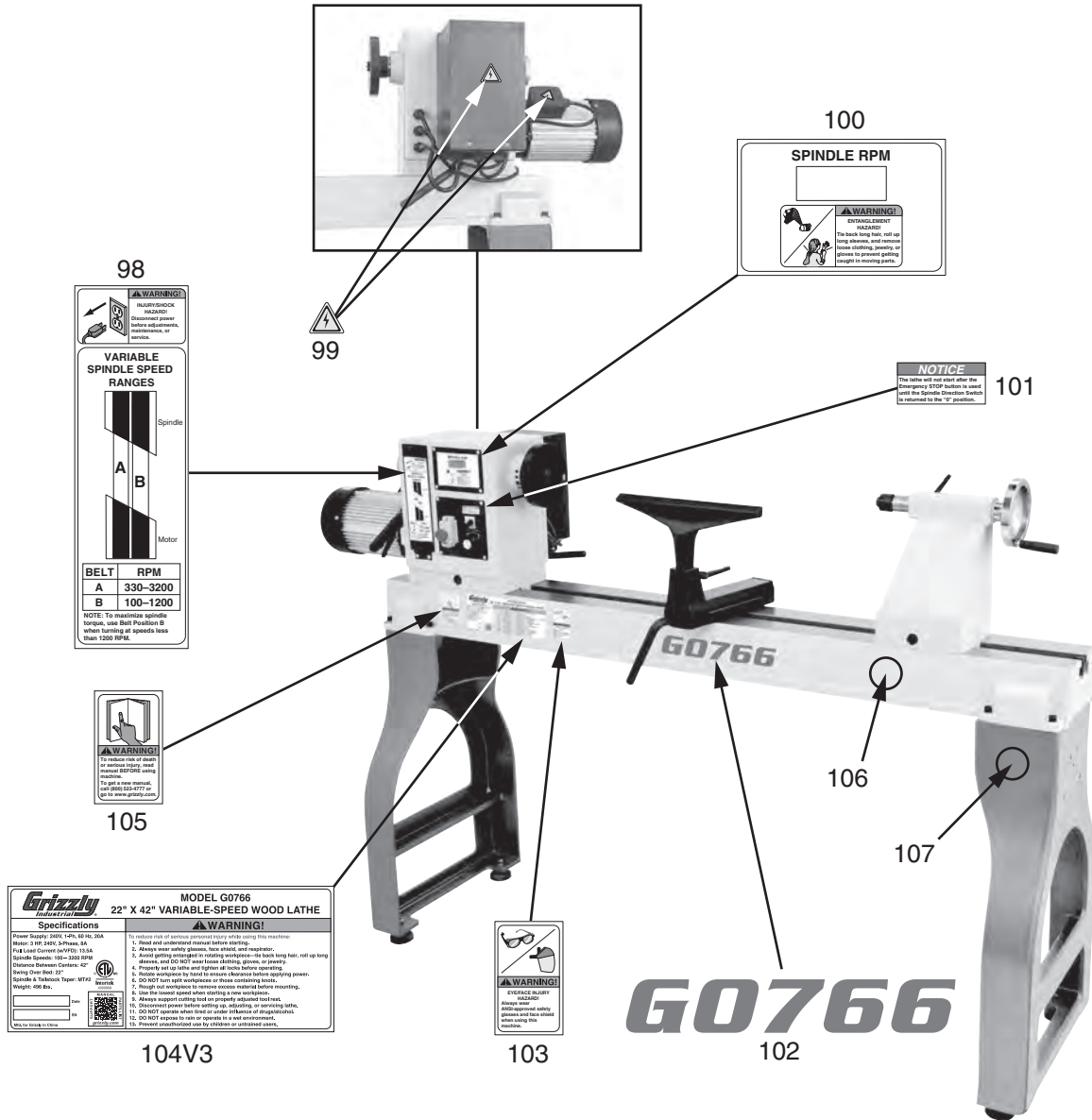

REF	PART #	DESCRIPTION
98	P0766098	SPINDLE SPEED CHART
99	P0766099	ELECTRICITY LABEL
100	P0766100	SPINDLE RPM LABEL
101	P0766101	SPINDLE DIRECTION SWITCH NOTICE
102	P0766102	MODEL NUMBER LABEL

REF	PART #	DESCRIPTION
103	P0766103	EYE/FACE INJURY HAZARD LABEL
104V3	P0766104V3	MACHINE ID LABEL V3.11.19
105	P0766105	READ MANUAL LABEL
106	P0766106	BEIGE TOUCH-UP PAINT
107	P0766107	GRIZZLY GREEN TOUCH-UP PAINT

⚠️ WARNING

Safety labels help reduce the risk of serious injury caused by machine hazards. If any label comes off or becomes unreadable, the owner of this machine **MUST** replace it in the original location before resuming operations. For replacements, contact (800) 523-4777 or www.grizzly.com.

