

SECTION 9: PARTS

Head Breakdown

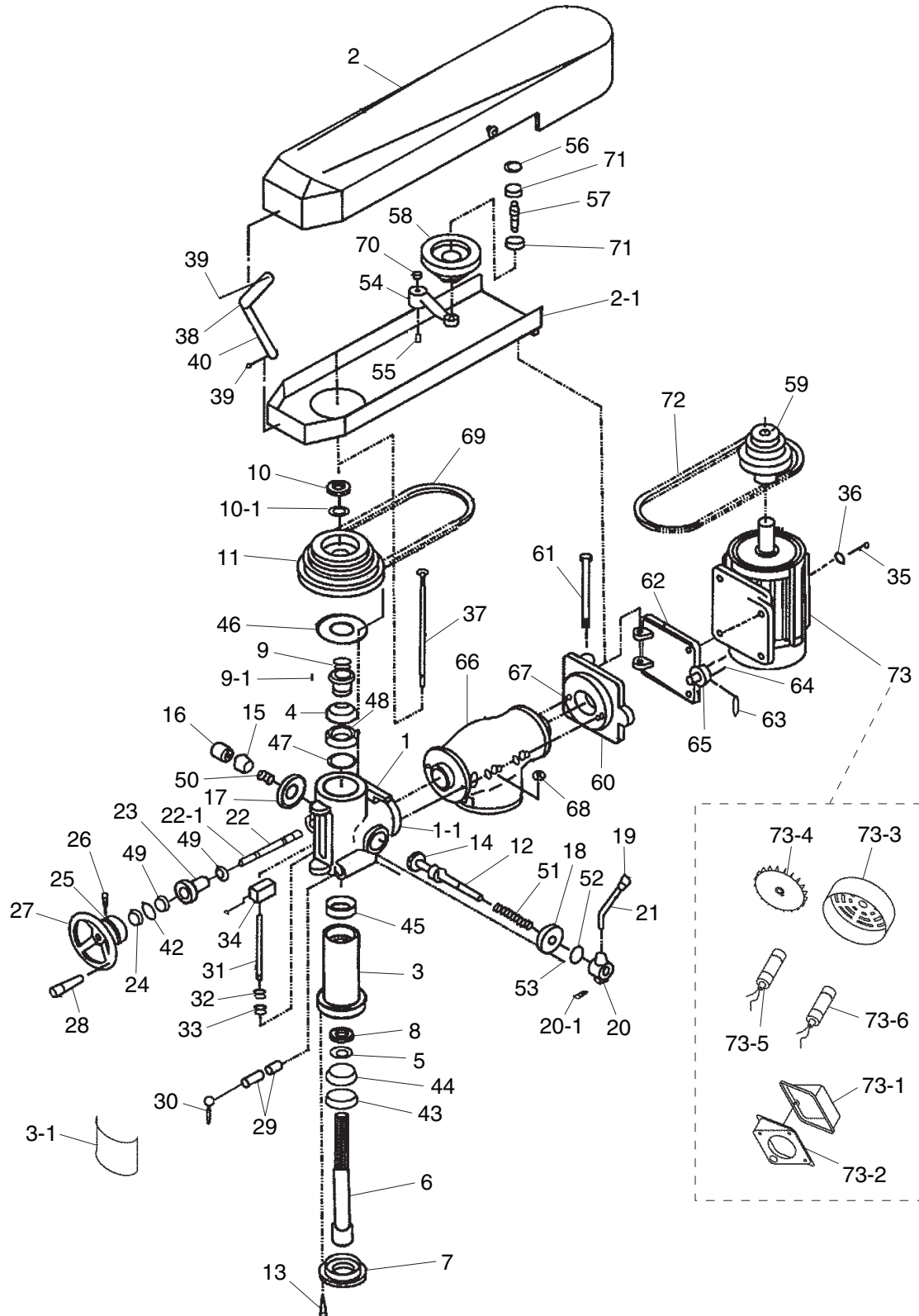

Head Parts List

REF	PART #	DESCRIPTION
1	P3102001	HEAD CASTING
1-1	P3102001-1	HEAD ROTATION SCALE
2	P3102002	BELT HOUSING COVER
2-1	P3102002-1	BELT HOUSING BASE
3	P3102003	QUILL
3-1	P3102003-1	PLASTIC QUILL GUARD
4	P6009	BALL BEARING 6009ZZ
5	P3102005	SPANNER WASHER 30MM
6	P3102006	SPINDLE
7	P3102007	SPINDLE END CAP
8	P3102008	SPANNER NUT M30-1.5
9	P3102009	SPINDLE SLEEVE
9-1	PK34M	KEY 5 X 5 X 20
10	P3102010	SPANNER NUT M45-1.5
10-1	P3102010-1	SPANNER WASHER 45MM
11	P3102011	SPINDLE PULLEY
12	P3102012	QUILL PINION SHAFT
13	PSB50M	CAP SCREW M5-.8 X 10
14	P3102014	CLUTCH WORM GEAR
15	P3102015	CLUTCH
16	P3102016	CLUTCH ADJUSTING NUT M18-1.5 X 35
17	P3102017	CLUTCH COVER
18	P3102018	PINION SHAFT SEAT
19	P3102019	KNOB
20	P3102020	COARSE LEVER HUB
20-1	PSS85M	SET SCREW M6-1 X 45
21	P3102021	COARSE LEVER
22	P3102022	WORM SHAFT
22-1	PK34M	KEY 5 X 5 X 20
23	P3102023	WORM SHAFT SLEEVE
24	P3102024	SPANNER NUT M14-1.5
25	P3102025	GRADUATED DIAL
26	P3102084	DIAL SCREW M5-.8 X 10
27	P3102027	HANDWHEEL
28	P3102028	HANDLE
29	P3102029	QUILL LOCKING BLOCK
30	P3102030	QUILL LOCKING BOLT M10-1.25 X 101
31	P3102031	DOWNFEED SCREW M12-1.25 X 184
32	P3102032	DOWNFEED STOP WHEEL M12-1.25
33	P3102033	DOWNFEED LOCK WHEEL M12-1.25
34	P3102034	QUILL DOG
35	PB09M	HEX BOLT M8-1.25 X 20
36	PW01M	FLAT WASHER 8MM

REF	PART #	DESCRIPTION
37	P3102037	DRAWBAR
38	P3102038	RIVET C5 X 15
39	PS09M	PHLP HD SCR M5-.8 X 10
40	P3102040	COVER SUPPORTING ARM
42	P3102042	SPANNER WASHER M14
43	P3102043	ANGULAR THRUST BEARING 36207
44	P6007	BALL BEARING 6007ZZ
45	P6206	BALL BEARING 6206ZZ
46	P3102046	BEARING COVER
47	P3102047	EXT RETAINING RING 75MM
48	P6009	BALL BEARING 6009ZZ
49	P8102	THRUST BEARING 8102
50	P3102050	COMPRESSION SPRING
51	P3102051	COMPRESSION SPRING
52	PR08M	EXT RETAINING RING 19MM
53	PSB28M	CAP SCREW M6-1 X 15
54	P3102054	SWIVEL ARM
55	P3102055	SWIVEL STUD
56	PR12M	EXT RETAINING RING 35MM
57	P3102057	PULLEY PIVOT STUD
58	P3102058	IDLER PULLEY
59	P3102059	MOTOR PULLEY
60	P3102060	MOTOR MOUNT ADAPTER
61	P3102061	MOTOR PIVOT BOLT
62	P3102062	MOTOR MOUNT
63	P3102063	V-BELT TENSION LOCK
64	P3102064	V-BELT TENSION SHAFT
65	P3102065	V-BELT TENSION PIN
66	P3102066	TURRET
67	P3102067	SPECIAL BOLT
68	PW04M	FLAT WASHER 10MM
69	PVA37	V-BELT 4L370
70	PN09M	HEX NUT M12-1.75
71	P6003	BALL BEARING 6003ZZ
72	PVA32	V-BELT 4L320
73	P3102073	MOTOR 1-1/2HP 110/220V 1PH
73-1	P3102073-1	MOTOR JUNCTION BOX COVER
73-2	P3102073-2	MOTOR JUNCTION BOX
73-3	P3102073-3	MOTOR FAN COVER
73-4	P3102073-4	MOTOR FAN
73-5	P3102073-5	S CAPACITOR 150M 250V 1-5/8 X 3-1/8
73-6	P3102073-6	R CAPACITOR 20M 450V 1-5/8 X 3-1/8



Main Breakdown

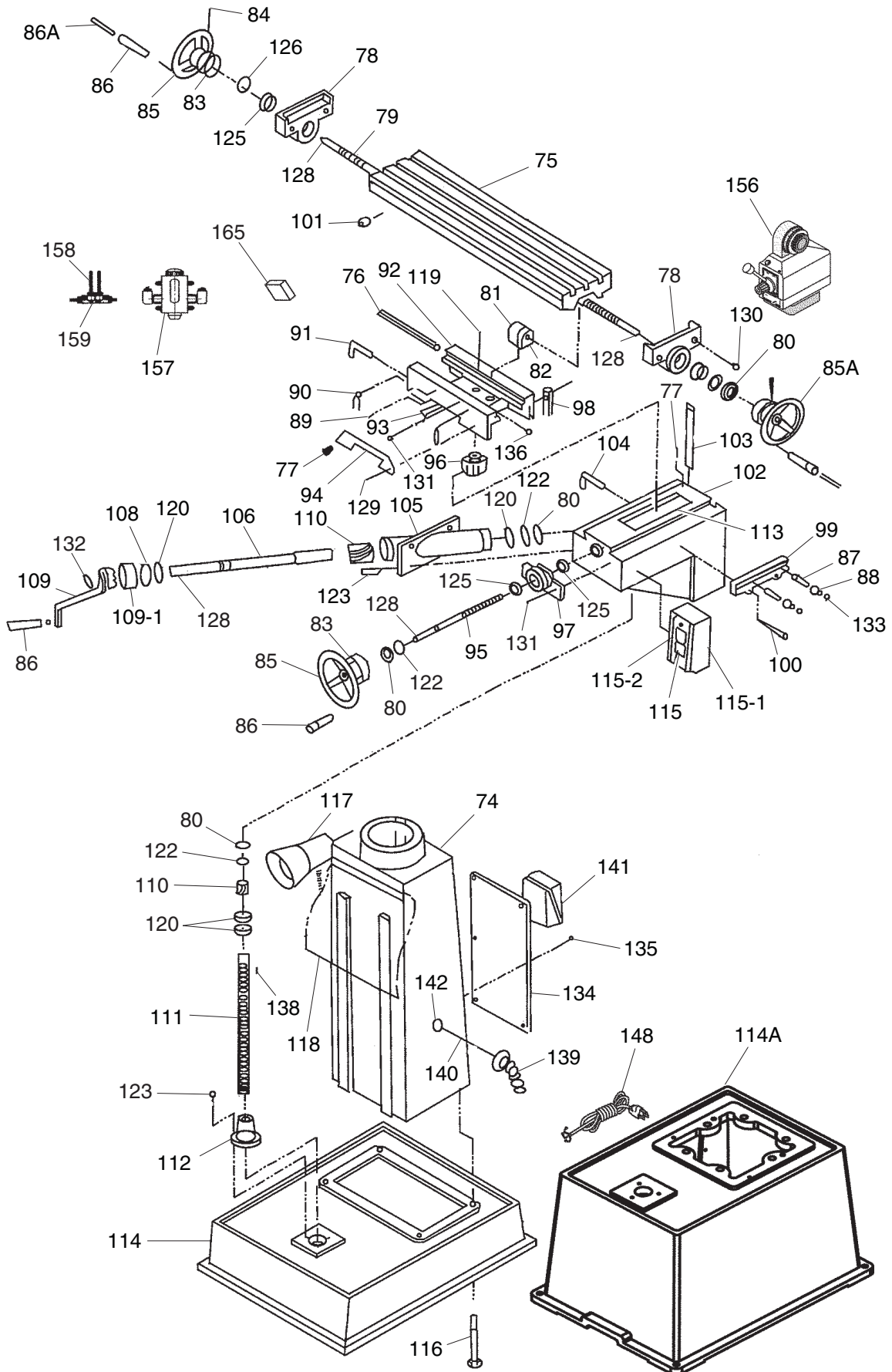

Main Parts List

REF	PART #	DESCRIPTION
74	P3102074	COLUMN
75	P3102075	TABLE
76	P3102076	TABLE GIB
77	P3102077	GIB ADJUSTING SCREW M6-1 X 32
78	P3102078	LONGITUDINAL BEARING BRACKET
79	P3102079	LONGITUDINAL LEADSCREW
80	P3102080	SPANNER NUT M20-1.5
81	P3102081	LONGITUDINAL LEADSCREW NUT
82	PSB38M	CAP SCREW M5-.8 X 25
83	P3102083	GRADUATED DIAL
84	P3102084	DIAL SCREW M5-.8 X 10
85	P3102085	HANDWHEEL LEFT-SIDE
85A	P3102085A	HANDWHEEL RIGHT SIDE
86	P3102086	HANDLE
86A	P3102086A	HANDLE SCREWS
87	PSB28M	CAP SCREW M6-1 X 15
88	P3102088	SLEEVE
89	P3102089	LIMIT STOP
90	P3102090	TABLE LOCK M10-1.5 X 24
91	P3102091	TABLE LOCK HANDLE
92	P3102092	SADDLE
93	P3102093	SADDLE GIB
94	P3102094	RUBBER WIPER
95	P3102095	CROSS LEADSCREW
96	P3102096	CROSS LEADSCREW NUT
97	P3102097	BEARING BRACKET
98	P3102098	CROSS STOP BLOCK
99	P3102099	LIMIT STOP TRACK
100	PSB06M	CAP SCREW M6-1 X 25
101	P3102101	SLEEVE
102	P3102102	KNEE
103	P3102103	KNEE GIB
104	P3102104	KNEE LOCK M5-.8 X 10
105	P3102105	GEAR SHAFT SLEEVE
106	P3102106	GEAR SHAFT
108	P3102108	ELEVATING HANDLE CLUTCH
109	P3102109	ELEVATION CRANK
109-1	P3102109-1	KNEE GRADUATED DIAL
110	P3102110	ELEVATION GEAR

REF	PART #	DESCRIPTION
111	P3102111	ELEVATION LEADSCREW
112	P3102112	ELEVATION LEADSCREW BASE
113	P3102113	CHIP GUARD
114	P3102114	BASE
114A	P3102114A	CABINET STAND
115	P3102115	POWER ON/OFF SWITCH 110V
115-1	P3102115-1	BLACK SWITCH BOX
115-2	P3102115-2	SPINDLE DIRECTION SWITCH
116	PB129M	HEX BOLT M14-2 X 50
117	P3102117	HALOGEN WORK LIGHT ASSY
118	P3102118	WAY COVER
119	PB10M	HEX BOLT M6-1 X 25
120	P6905ZZ	BALL BEARING 6905ZZ
122	P3102122	SPANNER WASHER 20MM
123	PSB14M	CAP SCREW M8-1.25 X 20
125	P6806ZZ	BALL BEARING 6806ZZ
126	P3102126	SPECIAL RETAINING RING
128	PK34M	KEY 5 X 5 X 20
129	PS04M	PHLP HD SCR M8-1.25 X 20
130	PSB14M	CAP SCREW M8-1.25 X 20
131	PSB14M	CAP SCREW M8-1.25 X 20
132	P3102132	SPECIAL RETAINING RING
133	PSB38M	CAP SCREW M5-.8 X 25
134	P3102134	REAR COLUMN COVER
135	PS11M	PHLP HD SCR M6-1 X 16
136	PSB45M	CAP SCREW M8-1.25 X 45
138	PK34M	KEY 5 X 5 X 20
139	P3102139	CONDUIT
140	P3102140	CABLE
141	P3102141	POWER WIRING JUNCTION BOX
142	P3102142	STRAIN RELIEF
148	PWRCRD110L	POWER CABLE W/ 5-15 PLUG
156	P3103145	POWER FEED (3103)
157	P3102157	ONE-SHOT OILER
158	P3102158	TUBING 4.1MM
159	P3102159	BRASS COUPLING 8MM
165	P3102165	LONG. LIMIT BLOCK (G3102)
165	P3103165	LONG. LIMIT SWITCH (G3103)



Electrical & Accessories Breakdown

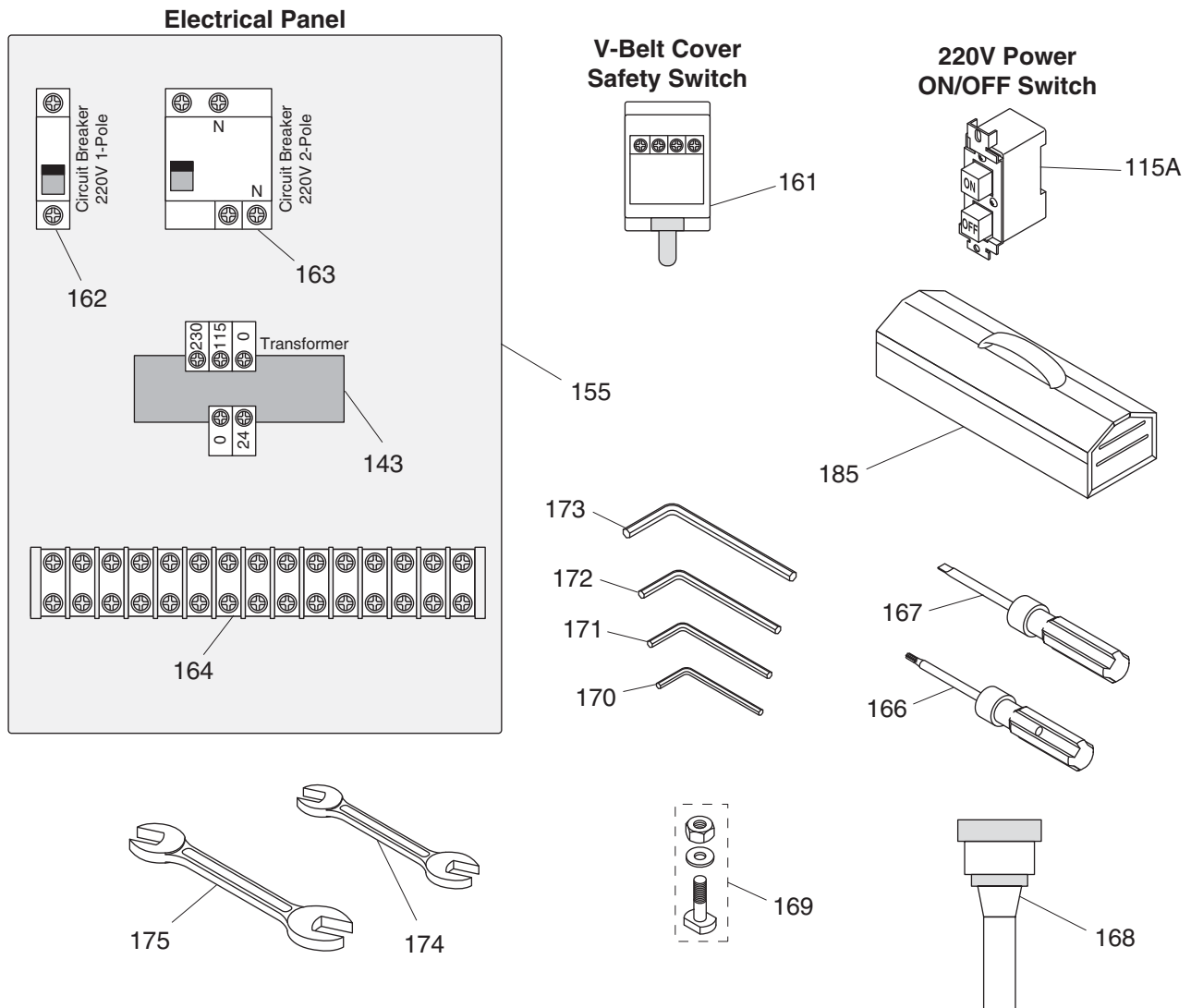

REF	PART #	DESCRIPTION
115A	P3102115A	POWER ON/OFF SWITCH 220V
143	P3102143	TRANSFORMER
161	P3102161	V-BELT SAFETY SWITCH
162	P3102162	CIRCUIT BREAKER 1-POLE 220V
163	P3102163	CIRCUIT BREAKER 2-POLE 220V
164	P3102164	TERMINAL BLOCK 15-POLE
166	PSDP2	SCREWDRIVER PHILLIPS #2
167	PSDF2	SCREWDRIVER FLAT #2
168	P3102168	FACE MILL 3"

REF	PART #	DESCRIPTION
169	P3102169	T-BOLT ASSY 3/8-16
170	PAW03M	HEX WRENCH 3MM
171	PAW04M	HEX WRENCH 4MM
172	PAW05M	HEX WRENCH 5MM
173	PAW06M	HEX WRENCH 6MM
174	PWR1012	WRENCH 10/12MM
175	PWR1618	WRENCH 16/18MM
185	P3102185	TOOLBOX



Label Placement

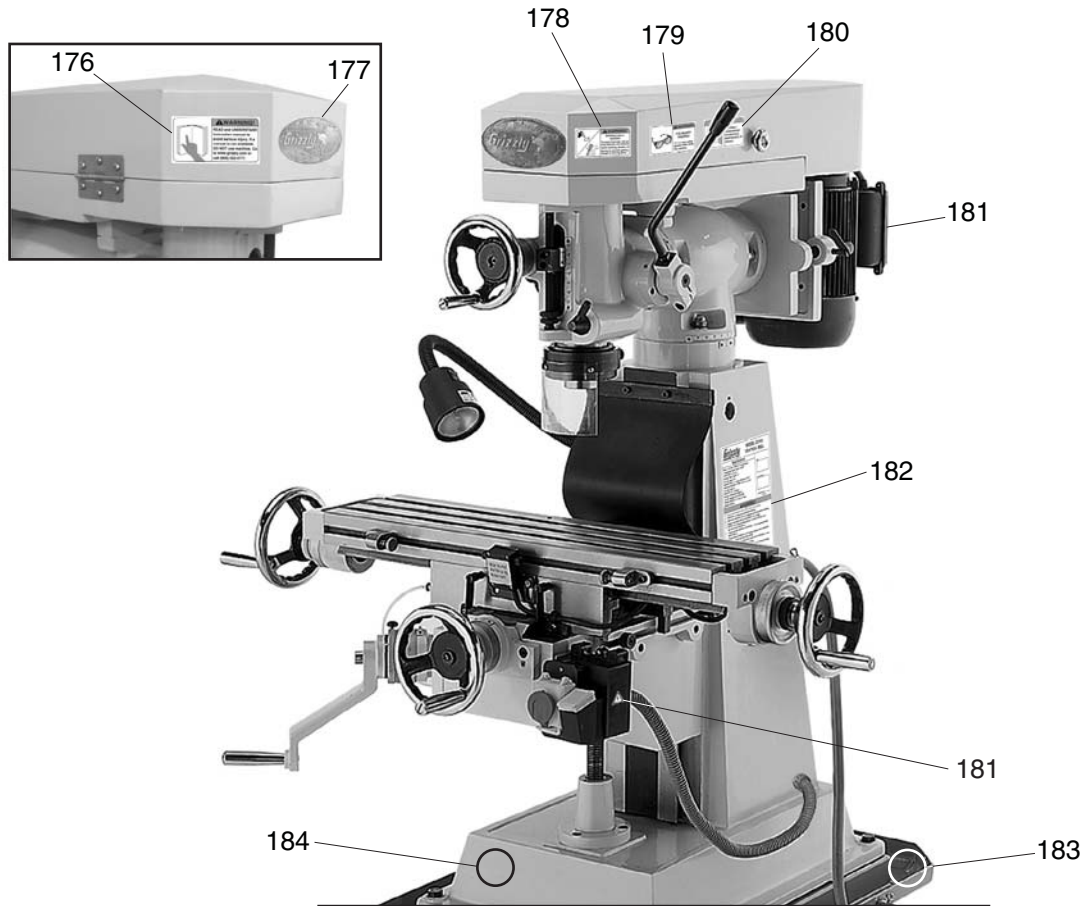

REF	PART #	DESCRIPTION
176	PLABEL-12B	READ MANUAL LABEL HL
177	G9987	GRIZZLY OVAL NAMPLATE SMALL
178	PLABEL-55B	ENTANGLEMENT HAZARD LABEL HL
179	PLABEL-11C	EYE INJURY HAZARD LABEL HL
180	PLABEL-62B	DISCONNECT WARNING LABEL HL

REF	PART #	DESCRIPTION
181	PLABEL-14A	ELECTRICITY LABEL
182	P3102182	MACHINE ID LABEL (G3102)
182	P3103182	MACHINE ID LABEL (G3103)
183	PPAINT-1	GRIZZLY GREEN TOUCH UP PAINT
184	PPAINT-11	GRIZZLY PUTTY TOUCH UP PAINT

WARNING

Safety labels warn about machine hazards and ways to prevent injury. The owner of this machine **MUST** maintain the original location and readability of the labels on the machine. If any label is removed or becomes unreadable, **REPLACE** that label before using the machine again. Contact Grizzly at (800) 523-4777 or www.grizzly.com to order new labels.

