

# READ THIS FIRST



Model G9860/ZX, G9953ZX/ZXF

**\*\*\*IMPORTANT UPDATE\*\*\***

For Machines Mfd. Since 05/24  
and Owner's Manual Revised 10/20

For questions or help with this product contact Tech Support at (570) 546-9663 or [techsupport@grizzly.com](mailto:techsupport@grizzly.com)

The following changes were recently made since the owner's manual was printed:

- Parts have changed.
- Inventory has changed.
- Steps in **Installing Fence** have been updated.
- Steps in **Adjusting Cutterhead Guard Tension** have been updated.

Aside from this information, all other content in the owner's manual applies and **MUST** be read and understood for your own safety. **IMPORTANT: Keep this update with the owner's manual for future reference.**

For questions or help, contact our Tech Support at (570) 546-9663 or [techsupport@grizzly.com](mailto:techsupport@grizzly.com).

## G9860 Revised Parts

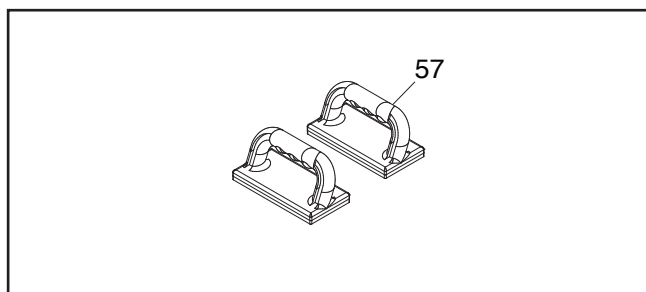

REF	PART #	DESCRIPTION
57	P9860057	PUSH BLOCK

## G9860ZX, G9953ZX/ZXF Revised Parts

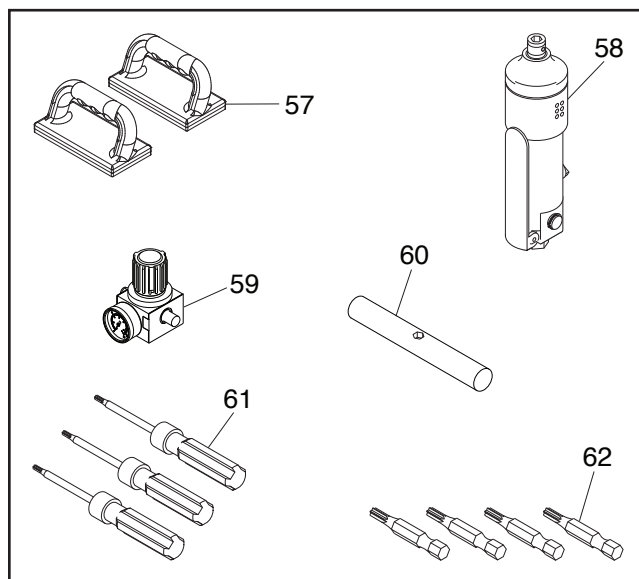

REF	PART #	DESCRIPTION
57	P9860ZX057	PUSH BLOCK
58	P9860ZX058	PNEUMATIC TORQUE WRENCH
59	P9860ZX059	AIR REGULATOR W/GAUGE
60	P9860ZX060	BREAKER BAR BIT HOLDER
61	P9860ZX061	TORX DRIVER T-20
62	P9860ZX062	TORX BIT T-20

COPYRIGHT © NOVEMBER, 2024 BY GRIZZLY INDUSTRIAL, INC.  
**WARNING: NO PORTION OF THIS MANUAL MAY BE REPRODUCED IN ANY SHAPE OR FORM WITHOUT THE WRITTEN APPROVAL OF GRIZZLY INDUSTRIAL, INC.**  
 #KS23440 PRINTED IN TAIWAN

# Revised Parts

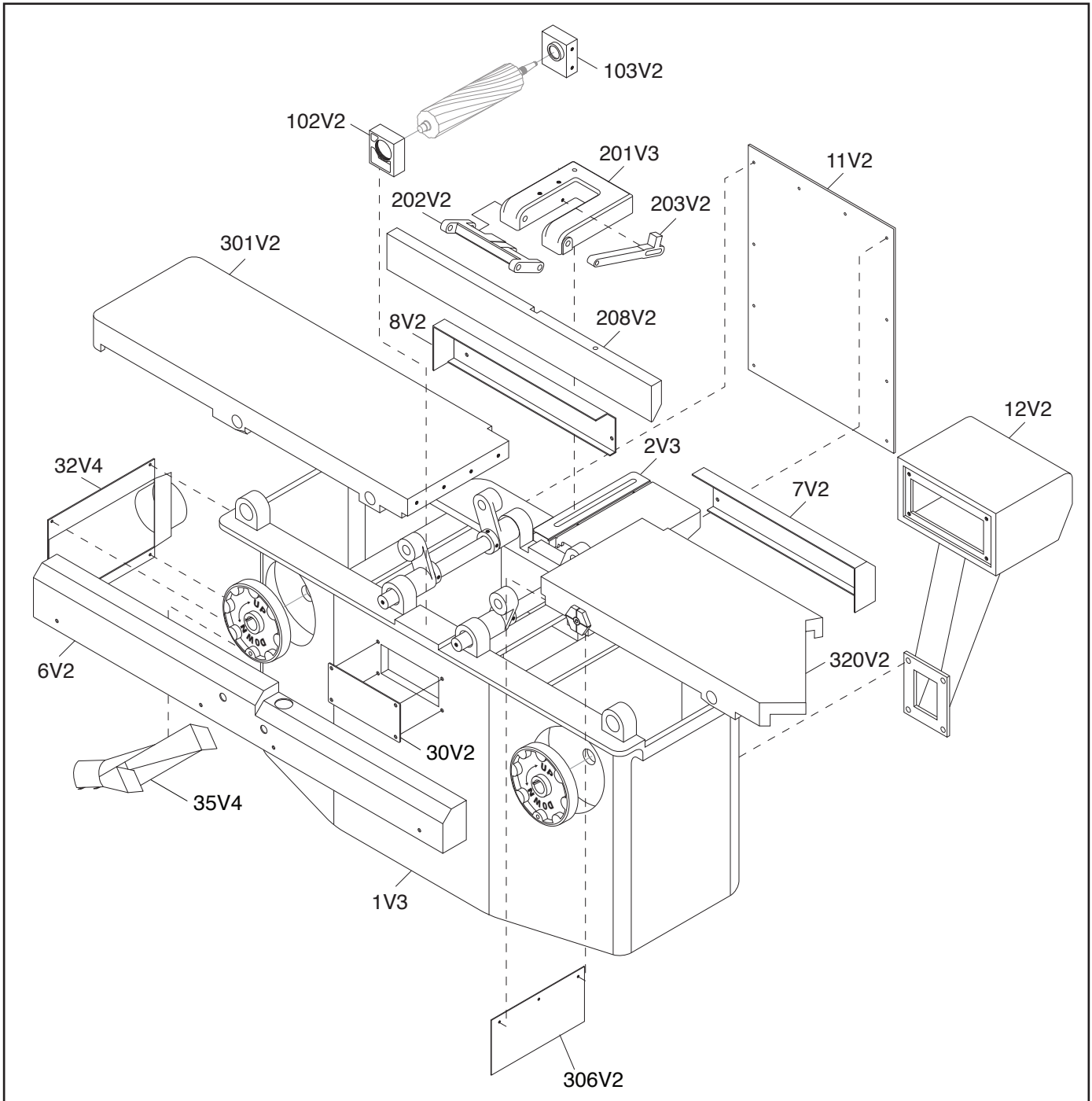

REF	PART #	DESCRIPTION
1V3	P9860ZX001V3	BASE V3.09.24
2V3	P9860ZX002V3	FENCE SEAT V3.09.24
6V2	P9860ZX006V2	FRONT TABLE COVER V2.09.24
7V2	P9860ZX007V2	INFEED TABLE REAR COVER V2.09.24
8V2	P9860ZX008V2	OUTFEED TABLE REAR COVER V2.09.24
11V2	P9860ZX011V2	MOTOR ACCESS COVER V2.09.24
12V2	P9860ZX012V2	CONTROL PANEL PEDESTAL V2.09.24
30V2	P9860ZX030V2	FRONT CABINET ACCESS COVER V2.09.24
32V4	P9860ZX032V4	DUST PORT PANEL 5" V4.09.24
35V4	P9860ZX035V4	DUST CHUTE 5" V4.09.24

REF	PART #	DESCRIPTION
102V2	P9860ZX102V2	FRONT BEARING HOUSING V2.09.24
103V2	P9860ZX103V2	REAR BEARING HOUSING V2.09.24
201V3	P9860ZX201V3	FENCE BASE V3.09.24
202V2	P9860ZX202V2	PIVOT BRACKET V2.09.24
203V2	P9860ZX203V2	CONNECTOR BRACKET V2.09.24
208V2	P9860ZX208V2	FENCE V2.09.24
301V2	P9860ZX301V2	OUTFEED TABLE V2.09.24
306V2	P9860ZX306V2	COVER V2.09.24
320V2	P9860ZX320V2	INFEED TABLE V2.09.24

**BUY PARTS ONLINE AT GRIZZLY.COM!**  
Scan QR code to visit our Parts Store.



# G9860ZX Labels & Cosmetics

714V2

**MODEL G9860ZX**  
**12" x 80" JOINTER W/ SPIRAL CUTTERHEAD**

**Specifications**

Motor: 3 HP, 230V, 1 Ph, 50 Hz  
Full-Load Current Rating: 15A  
Maximum Depth of Cut: 5/16"  
Cutterhead Type: Spiral  
Cutterhead Speed: 590 RPM  
No. of Cutter Rows: 6  
No. of Cuts Per Minute: 35,400  
No. of Inducible Cutters: 84  
Cutter Insert Size: 1/4 x 1/4 x 2mm  
Replacement Inserts: H7319  
Face Size: 38 1/4" x 1-1/2" x 4-3/4"  
Table Size: 12-1/2" x 80"  
Weight: 1200 lbs.

Mfg. for Grizzly in Taiwan

**WARNING!**

To reduce the risk of serious injury when using this machine:

- Read and understand owner's manual before operating.
- Always wear approved safety glasses, hearing protection, and respirator.
- Only plug power cord into a grounded outlet.
- Except when rabbeting, keep all guards in place and in proper operating condition. Always replace guard after rabbeting.
- Never edge-joint stock smaller than 14" long, 3/4" wide, or 1/2" thick.
- Never face-glide stock smaller than 14" long, 3/4" wide, or 1/2" thick.
- Always use push blocks when face planing.
- Keep hands at least 12" away from cutterhead.
- Never cut deeper than 5/16" on a single pass.

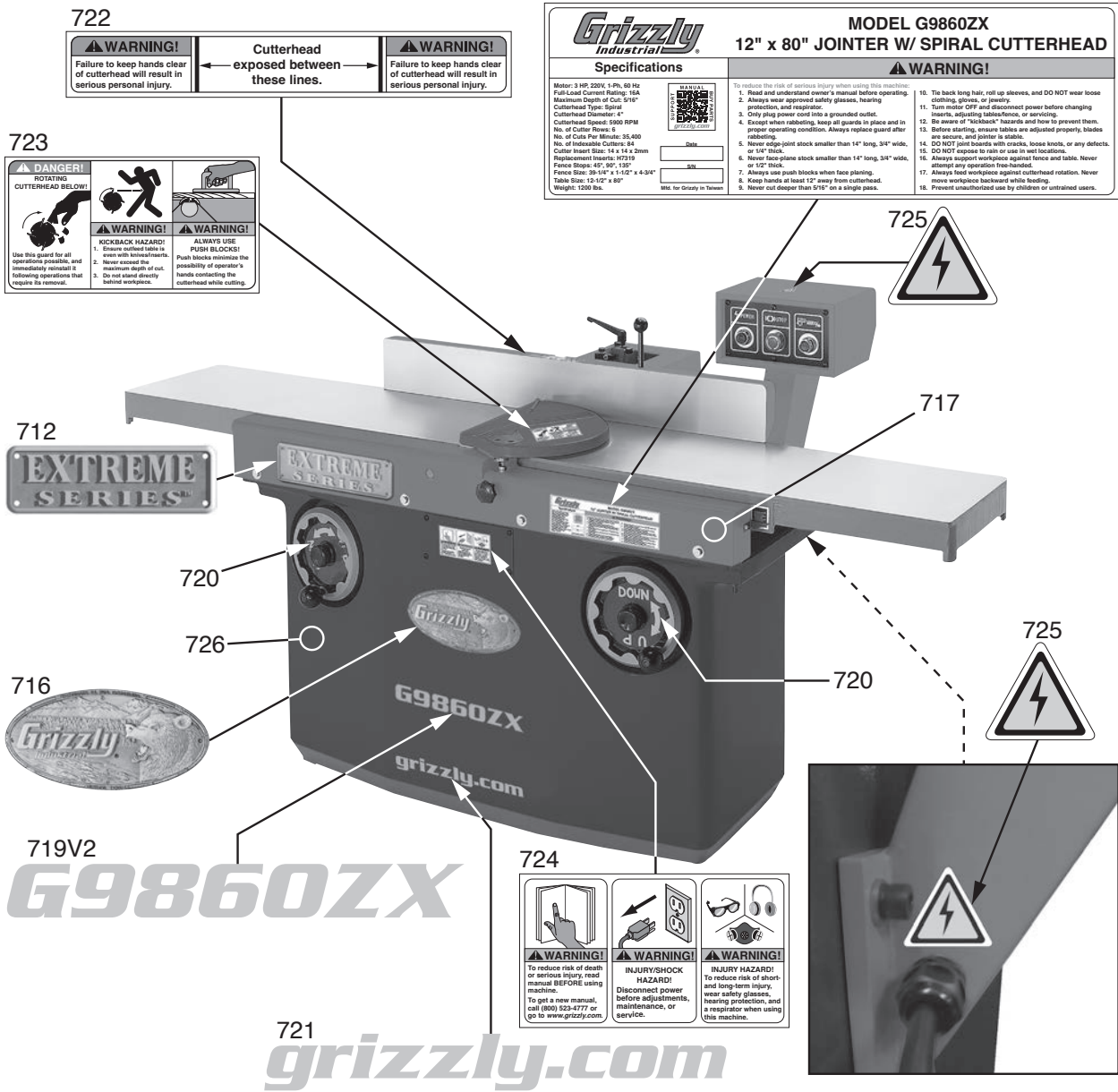

REF	PART #	DESCRIPTION
712	P9860ZX712	EXTREME SERIES NAMEPLATE
714V2	P9860ZX714V2	MACHINE ID/LABEL V2.09.24
716	P9860ZX716	GRIZZLY NAMEPLATE-LARGE
717	P9860ZX717	TOUCH-UP PAINT, GRIZZLY GREEN
719V2	P9860ZX719V2	MODEL NUMBER LABEL V2.09.24
720	P9860ZX720	HANDWHEEL UP/DOWN LABEL

REF	PART #	DESCRIPTION
721	P9860ZX721	GRIZZLY.COM LABEL
722	P9860ZX722	CUTTERHEAD EXPOSED LABEL
723	P9860ZX723	CUTTERHEAD WARNING
724	P9860ZX724	COMBO WARNING LABEL
725	P9860ZX725	ELECTRICITY LABEL
726	P9860ZX726	TOUCH-UP PAINT, GLOSSY BLACK

**WARNING!**

Safety labels help reduce the risk of serious injury caused by machine hazards. If any label comes off or becomes unreadable, the owner of this machine **MUST** replace it in the original location before resuming operations. For replacements, contact (800) 523-4777 or [www.grizzly.com](http://www.grizzly.com).



## G9860/ZX Revised Parts

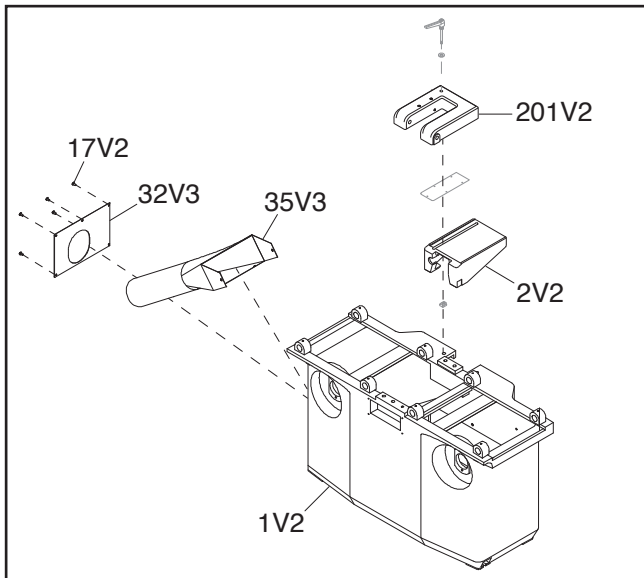

REF	PART #	DESCRIPTION
1V2	P9860001V2	BASE V2.01.21
2V2	P9860002V2	FENCE SEAT V2.03.23
17V2	P9860017V2	HEX BOLT M6-1 X 12 V2.01.21
32V3	P9860032V3	DUST PORT PANEL 5" V3.01.21
35V3	P9860035V3	DUST CHUTE 5" V3.01.21
201V2	P9860201V2	FENCE BASE V2.03.23

## G9953ZX/ZXF Revised Parts

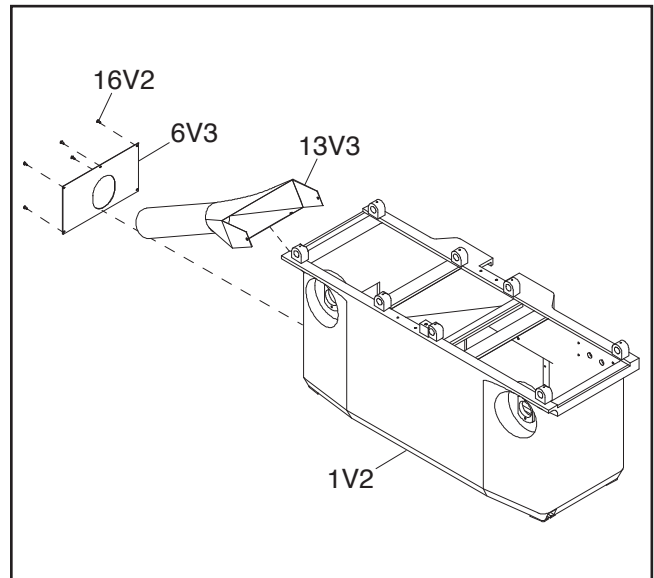

REF	PART #	DESCRIPTION
1V2	P9953ZX001V2	BASE V2.01.21
6V3	P9953ZX006V3	DUST HOOD 5" V3.01.21
13V3	P9953ZX013V3	DUST CHUTE 5" V3.01.21
16V2	P9953ZX016V2	HEX BOLT M6-1 X 12 V2.01.21



# SECTION 9: PARTS

## G9860/ZX Cabinet

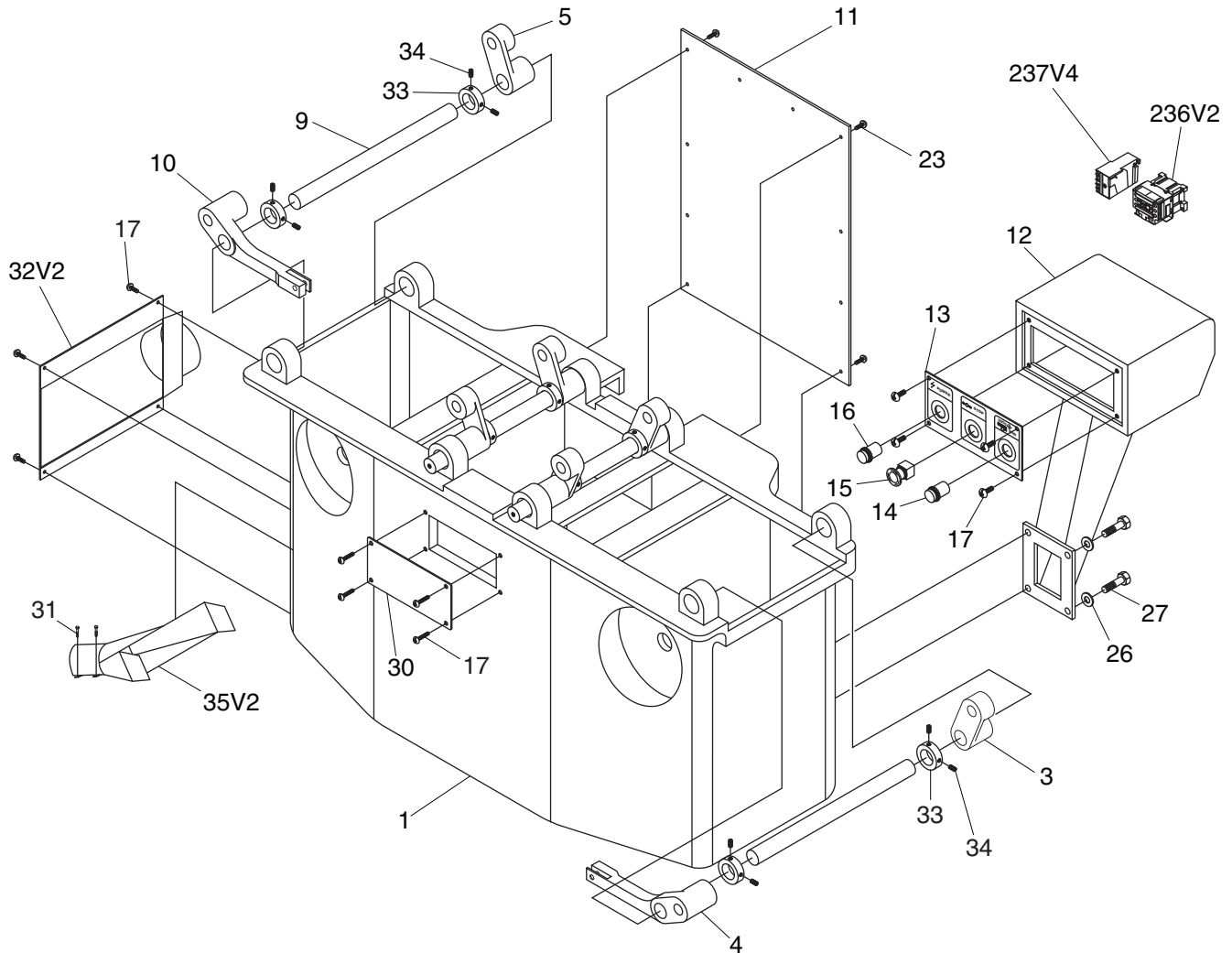

REF	PART #	DESCRIPTION
1	P9860001	BASE
3	P9860003	INFEED TABLE SUPPORT
4	P9860004	INFEED TABLE LIFTING ARM
5	P9860005	OUTFEED TABLE SUPPORT
9	P9860009	TABLE HEIGHT SPINDLE
10	P9860010	OUTFEED TABLE LIFTING ARM
11	P9860011	MOTOR ACCESS COVER
12	P9860012	CONTROL PANEL PEDESTAL
13	P9860013	CONTROL PANEL
14	P9860014	ON BUTTON
15	P9860015	STOP BUTTON
16	P9860016	POWER LAMP

REF	PART #	DESCRIPTION
17	P9860017	PHLP HD SCR M6-1 X 10
23	P9860023	PHLP HD SCR M6-1 X 10
26	P9860026	FLAT WASHER 10MM
27	P9860027	CAP SCREW M10-1.5 X 25
30	P9860030	FRONT CABINET ACCESS COVER
31	P9860031	HEX BOLT M6-1 X 12
32V2	P9860032V2	DUST PORT 5" V2.10.20
33	P9860033	LOCK COLLAR
34	P9860034	SET SCREW M8-1.25 X 8
35V2	P9860035V2	DUST CHUTE 5" V2.10.20
236V2	P9860236V2	CONTACTOR TECO CU-18 220V V2.05.08
237V4	P9860237V4	OL RELAY TE LR97D25M7 5-25A V4.09.11



# G9860/ZX Cutterhead & Motor

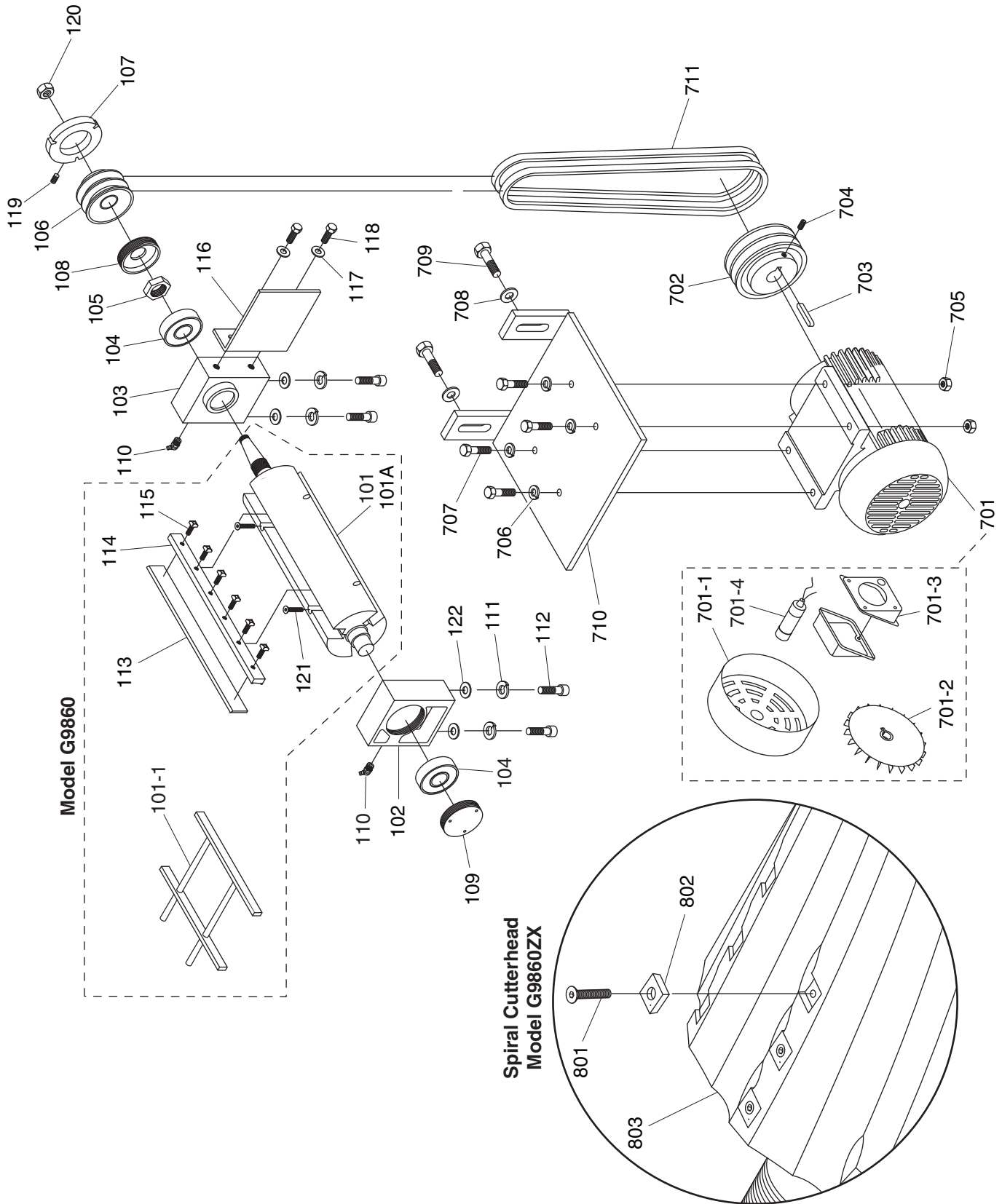

# G9860 Cutterhead & Motor Parts List

REF	PART #	DESCRIPTION
101-1	P9860101-1	JOINTER PAL CARBIDE JIG
101	P9860101	CUTTERHEAD 3 KNIFE V1.08.02
101A	P9860101A	CUTTERHEAD 4 KNIFE V2.03.05
102	P9860102	FRONT BEARING HOUSING
103	P9860103	REAR BEARING HOUSING
104	P9860104	BALL BEARING 6305VV
105	P9860105	SPANNER NUT M21-1.5
106	P9860106	CUTTERHEAD PULLEY
107	P9860107	CUTTERHEAD STOP PLATE
108	P9860108	REAR BEARING CAP
109	P9860109	FRONT BEARING CAP
110	P9860110	GREASE FITTING
111	P9860111	LOCK WASHER 10MM
112	P9860112	CAP SCREW M10-1.5 X 45
113	P9860113	KNIFE 1-3/16" X 12" X 1/8"
114	P9860114	KNIFE GIB 12"
115	P9860115	GIB BOLT M8-1.25 X 10
116	P9860116	BRACKET
117	P9860117	FLAT WASHER 10MM
118	P9860118	HEX BOLT M10-1.5 X 16

REF	PART #	DESCRIPTION
119	P9860119	SET SCREW M8-1.25 X 20
120	P9860120	SPECIAL HEX NUT M17-1.5
121	P9860121	JACK SCREW M6-1 X 16
122	P9860122	FLAT WASHER 10MM
701	P9860701	MOTOR 3HP 220V 1PH
701-1	P9860701-1	MOTOR FAN COVER
701-2	P9860701-2	MOTOR FAN
701-3	P9860701-3	MOTOR WIRING JUNCTION BOX
701-4	P9860701-4	S CAP. 400M 250V 1-3/4 X 3-1/2
702	P9860702	MOTOR PULLEY
703	P9860703	KEY 7 X 7 X 35
704	P9860704	SET SCREW 5/16-18 X 1/2
705	P9860705	HEX NUT M10-1.5
706	P9860706	LOCK WASHER 10MM
707	P9860707	HEX BOLT M10-1.5 X 40
708	P9860708	FLAT WASHER 1/2
709	P9860709	HEX BOLT M12-1.75 X 40
710	P9860710	MOTOR MOUNT PLATE
711V2	P9860711V2	V-BELT A47

# G9860ZX Cutterhead & Motor Parts List

REF	PART #	DESCRIPTION
102	P9860ZX102	FRONT BEARING HOUSING
103	P9860ZX103	REAR BEARING HOUSING
104	P9860ZX104	BALL BEARING 6305VV
105	P9860ZX105	SPANNER NUT M21-1.5
106	P9860ZX106	CUTTERHEAD PULLEY
107	P9860ZX107	CUTTERHEAD STOP PLATE
108	P9860ZX108	REAR BEARING CAP
109	P9860ZX109	FRONT BEARING CAP
110	P9860ZX110	GREASE FITTING
111	P9860ZX111	LOCK WASHER 10MM
112	P9860ZX112	CAP SCREW M10-1.5 X 45
116	P9860ZX116	BRACKET
117	P9860ZX117	FLAT WASHER 10MM
118	P9860ZX118	HEX BOLT M10-1.5 X 16
119	P9860ZX119	SET SCREW M8-1.25 X 20
120	P9860ZX120	SPECIAL HEX NUT M17-1.5
122	P9860ZX122	FLAT WASHER 10MM
701	P9860ZX701	MOTOR 3HP 220V 1PH

REF	PART #	DESCRIPTION
701-1	P9860ZX701-1	MOTOR FAN COVER
701-2	P9860ZX701-2	MOTOR FAN
701-3	P9860ZX701-3	MOTOR WIRING JUNCTION BOX
701-4	P9860ZX701-4	S CAP. 400M 250V 1-3/4 X 3-1/2
702	P9860ZX702	MOTOR PULLEY
703	P9860ZX703	KEY 7 X 7 X 35
704	P9860ZX704	SET SCREW 5/16-18 X 1/2
705	P9860ZX705	HEX NUT M10-1.5
706	P9860ZX706	LOCK WASHER 10MM
707	P9860ZX707	HEX BOLT M10-1.5 X 40
708	P9860ZX708	FLAT WASHER 1/2
709	P9860ZX709	HEX BOLT M12-1.75 X 40
710	P9860ZX710	MOTOR MOUNT PLATE
711V2	P9860ZX711V2	V-BELT A47
801	P9860ZX801	FLAT HD TORX T20 M6-1 X 15
802	P9860ZX802	INDEXABLE INSERT 14 X 14 X 2MM
803	P9860ZX803	SPIRAL CUTTERHEAD 12"



# G9860/ZX Fence

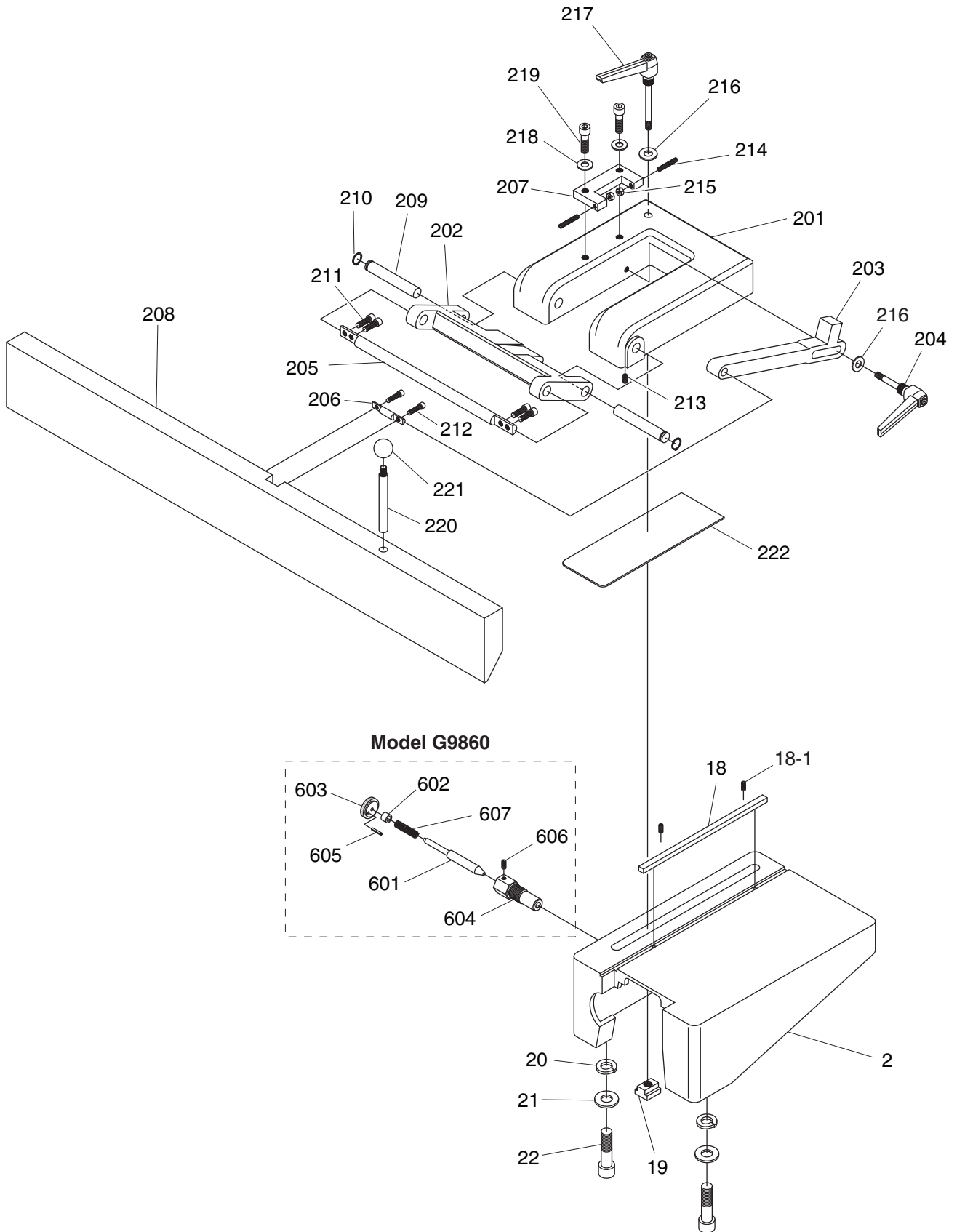

# G9860/ZX Fence Parts List

REF	PART #	DESCRIPTION
2	P9860002	FENCE SEAT
18	P9860018	KEY 10 X 8 X 300
18-1	P9860018-1	ROLL PIN 5 X 25
19	P9860019	FENCE LOCK T-NUT
20	P9860020	LOCK WASHER 16MM
21	P9860021	FLAT WASHER 16MM
22	P9860022	CAP SCREW M12-1.75 X 30
201	P9860201	FENCE BASE
202	P9860202	PIVOT BRACKET
203	P9860203	CONNECTOR BRACKET
204	P9860204	TILT LOCK LEVER ASSY
205	P9860205	LOWER FENCE ROD
206	P9860206	CLAMP ROD
207	P9860207	STOP BRACKET
208	P9860208	FENCE
209	P9860209	UPPER FENCE ROD
210	P9860210	EXT RETAINING RING 16MM
211	P9860211	CAP SCREW M5-.8 X 20

REF	PART #	DESCRIPTION
212	P9860212	CAP SCREW M5-.8 X 16
213	P9860213	SET SCREW M6-1 X 12
214	P9860214	SET SCREW M6-1 X 35
215	P9860215	HEX NUT M6-1
216	P9860216	FLAT WASHER 1/2
217	P9860217	FENCE LOCK LEVER ASSY
218	P9860218	FLAT WASHER 10MM
219	P9860219	CAP SCREW M10-1.5 X 25
220	P9860220	FENCE ADJUSTMENT HANDLE
221	P9860221	KNOB 3/8"-16
222	P9860222	DUST COVER
601	P9860601	ROD
602	P9860602	COLLAR
603	P9860603	KNURLED KNOB
604	P9860604	BRAKE CASING
605	P9860605	ROLL PIN 3 X 18
606	P9860606	SET SCREW M6-1 X 6
607	P9860607	COMPRESSION SPRING



# G9860/ZX Table

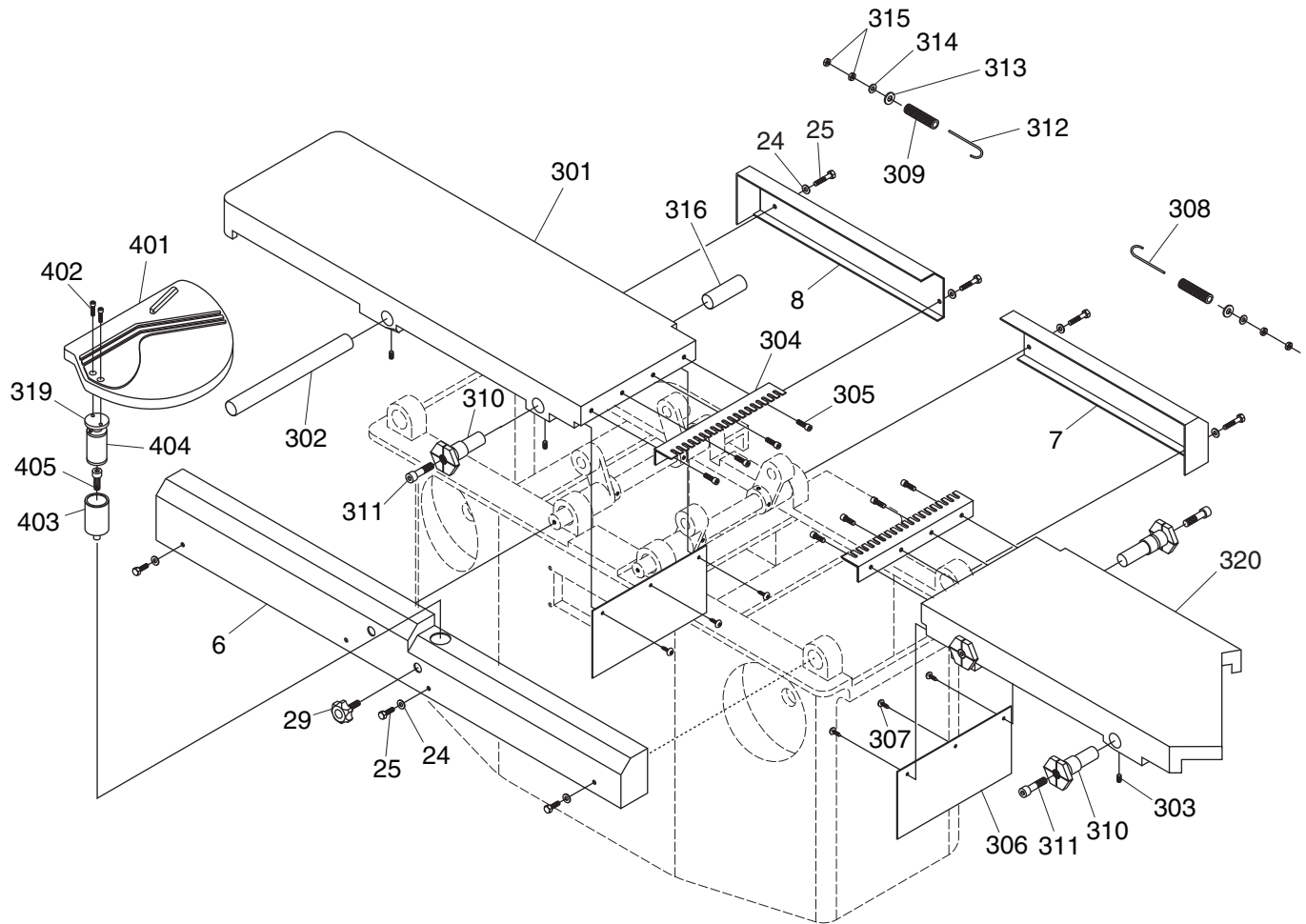

REF	PART #	DESCRIPTION
6	P9860006	FRONT TABLE COVER
7	P9860007	INFEED TABLE REAR COVER
8	P9860008	OUTFEED TABLE REAR COVER
24	P9860024	FLAT WASHER 8MM
25	P9860025	HEX BOLT M8-1.25 X 16
29	P9860029	KNOB M10-1.5 X 30
301	P9860301	OUTFEED TABLE
302	P9860302	TABLE PIVOT ROD LONG
303	P9860303	SET SCREW M8-1.25 X 10
304	P9860304	NOISE DAMPER
305	P9860305	CAP SCREW M6-1 X 12
306	P9860306	COVER
307	P9860307	PHLP HD SCR M6-1 X 12
308	P9860308	J-ROD LONG
309	P9860309	TENSION SPRING

REF	PART #	DESCRIPTION
310	P9860310	BED PIVOT PIN
311	P9860311	CAP SCREW M10-1.5 X 45
312	P9860312	J-ROD SHORT
313	P9860313	FLAT WASHER 1/2
314	P9860314	FLAT WASHER 3/8
315	P9860315	HEX NUT M12-1.75
316	P9860316	TABLE PIVOT ROD SHORT
319	P9860319	SPRING SHAFT COVER
320	P9860320	INFEED TABLE
401	P9860401	CUTTERHEAD GUARD
402	P9860402	CAP SCREW M8-1.25 X 25
403	P9860403	SPRING SHAFT HOUSING
404	P9860404	SPRING SHAFT
405	P9860405	CAP SCREW M12-1.75 X 20



# G9860/ZX Handwheel

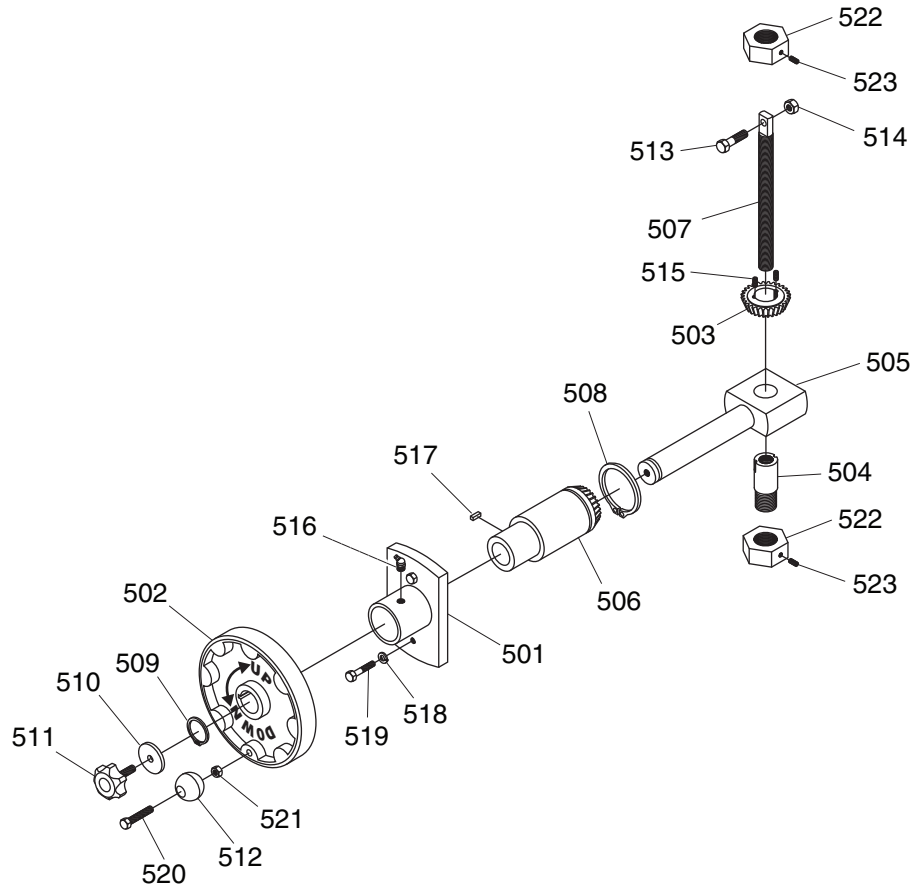

REF	PART #	DESCRIPTION
501	P9860501	LIFT ROD BRACKET
502	P9860502	HANDWHEEL
503	P9860503	BEVEL GEAR
504	P9860504	SLEEVE
505	P9860505	LIFT ROD
506	P9860506	GEAR SHAFT
507	P9860507	LIFT CONNECTOR
508	P9860508	SPECIAL EXT RETAINER RING
509	P9860509	EXT RETAINING RING 22MM
510	P9860510	SPECIAL FLAT WASHER D12 X 8MM
511	P9860511	LOCK KNOB M10-1.5 X 20MM
512	P9860512	HANDWHEEL KNOB 3/8"-16

REF	PART #	DESCRIPTION
513	P9860513	CAP SCREW M10-1.5 X 40
514	P9860514	HEX NUT M10-1.5
515	P9860515	SET SCREW M4-.7 X 10
516	P9860516	GREASE FITTING
517	P9860517	KEY 5 X 5 X 15
518	P9860518	LOCK WASHER 8MM
519	P9860519	HEX BOLT M8-1.25 X 25
520	P9860520	HEX BOLT 3/8-16 X 2
521	P9860521	HEX NUT 3/8"-16
522	P9860522	SPECIAL NUT M25-1.5
523	P9860523	SET SCREW M6-1 X 6



# G9953ZX/ZXF Cabinet

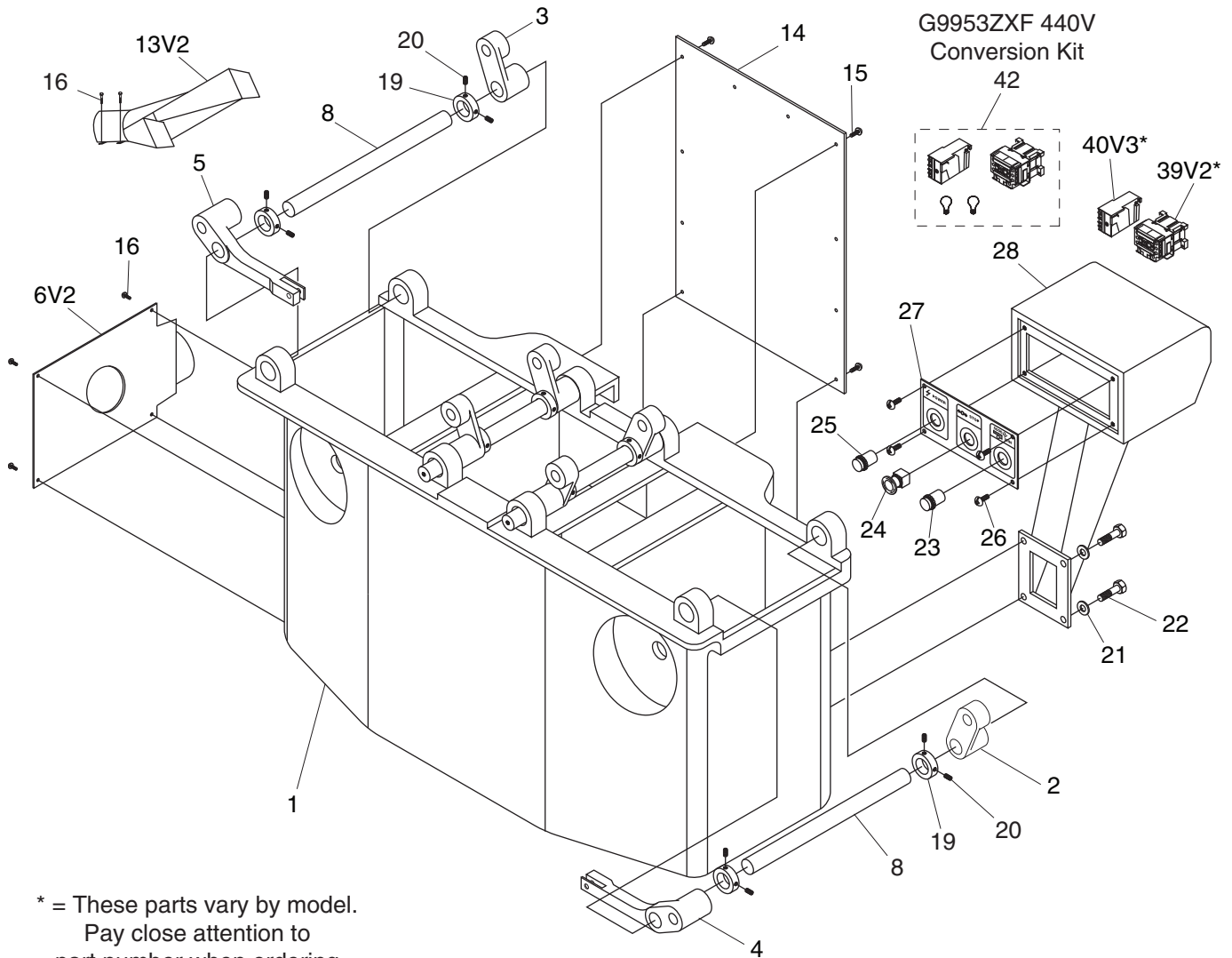

\* = These parts vary by model.  
Pay close attention to  
part number when ordering.

REF PART #	DESCRIPTION
1	P9953ZX001 BASE
2	P9953ZX002 INFEEED TABLE SUPPORT
3	P9953ZX003 OUTFEED TABLE SUPPORT
4	P9953ZX004 INFEEED TABLE LIFTING ARM
5	P9953ZX005 OUTFEED TABLE LIFTING ARM
6V2	P9953ZX006V2 DUST HOOD 5" V2.10.20
8	P9953ZX008 TABLE HEIGHT SPINDLE
13V2	P9953ZX013V2 DUST CHUTE 5" V2.10.20
14	P9953ZX014 MOTOR ACCESS COVER
15	P9953ZX015 PHLP HD SCR M6-1 X 10
16	P9953ZX016 PHLP HD SCR M6-1 X 12
19	P9953ZX019 STOP COLLAR
20	P9953ZX020 SET SCREW M8-1.25 X 8

REF PART #	DESCRIPTION
21	P9953ZX021 FLAT WASHER 10MM
22	P9953ZX022 CAP SCREW M10-1.5 X 25
23	P9953ZX023 ON BUTTON
24	P9953ZX024 STOP BUTTON
25	P9953ZX025 POWER LAMP
26	P9953ZX026 PHLP HD SCR M6-1 X 12
27	P9953ZX027 CONTROL PANEL
28	P9953ZX028 CONTROL PANEL PEDESTAL
39V2	P9953ZX039V2 CONTACTOR TECO CU-18 220V V2.05.08
39V2	P9953ZXF039V2 CONTACTOR TECO CU-18 440V V2.05.08
40V3	P9953ZX040V3 OL RELAY TECO RHU-10 15-20A V3.01.11
40V3	P9953ZXF040V3 OL RELAY TECO RHU-10 15-20A V3.01.11
42	P9953ZXF042 440V CONVERSION KIT



# G9953ZX/ZXF Cutterhead

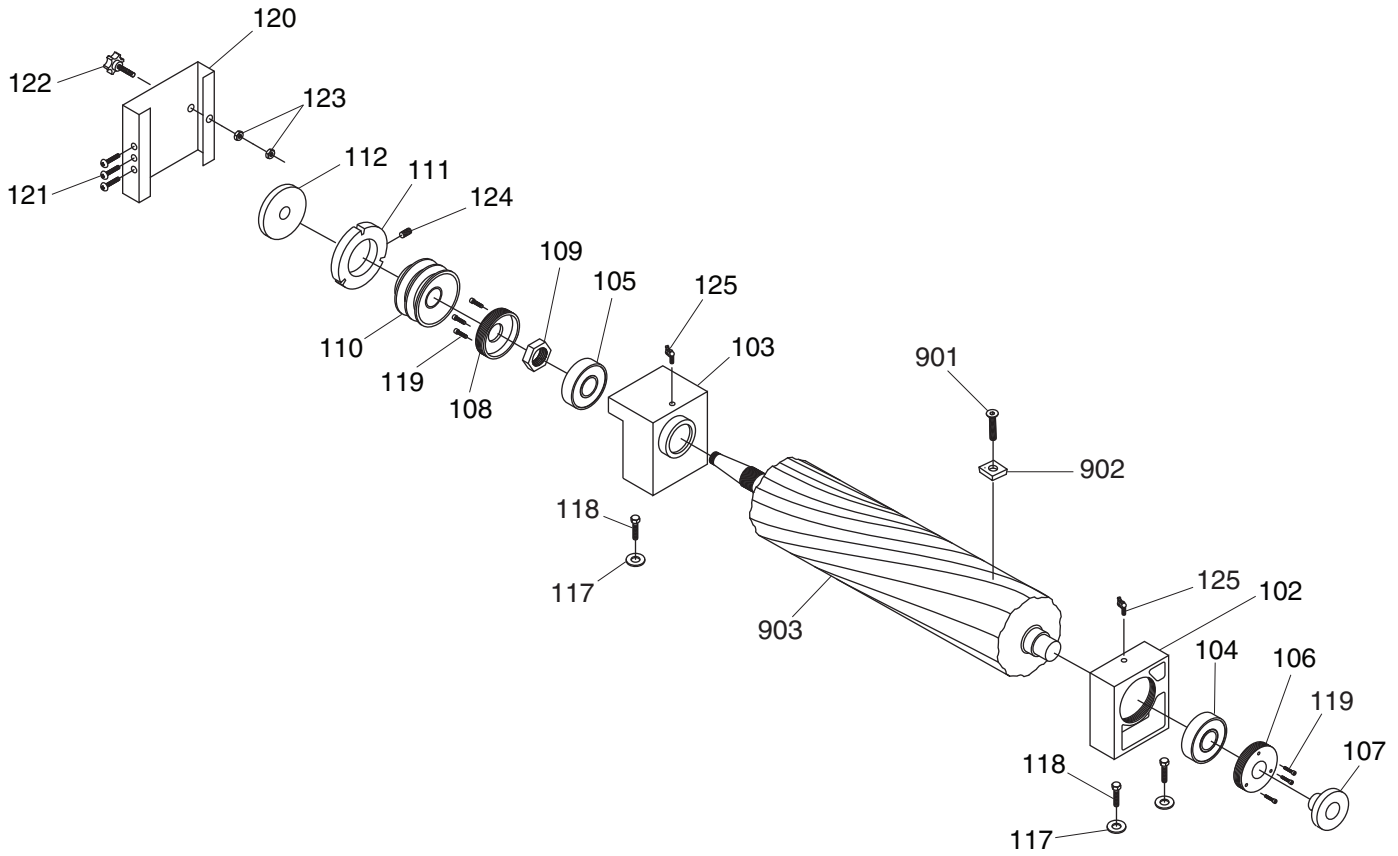

REF	PART #	DESCRIPTION
102	P9953ZX102	BEARING HOUSING FRONT
103	P9953ZX103	BEARING HOUSING REAR
104	P9953ZX104	BALL BEARING 6206ZZ
105	P9953ZX105	BALL BEARING 6208ZZ
106	P9953ZX106	BEARING END CAP
107	P9953ZX107	BRAKE NUT M30-1.5
108	P9953ZX108	BEARING CAP
109	P9953ZX109	SPANNER NUT M40-1.5P
110	P9953ZX110	CUTTERHEAD PULLEY
111	P9953ZX111	CUTTERHEAD STOP PLATE
112	P9953ZX112	END CAP
117	P9953ZX117	LOCK WASHER 10MM

REF	PART #	DESCRIPTION
118	P9953ZX118	HEX BOLT M10-1.5 X 30
119	P9953ZX119	CAP SCREW M5-.8 X 16
120	P9953ZX120	CUTTERHEAD REAR COVER
121	P9953ZX121	PHLP HD SCR M4-.7 X 15
122	P9953ZX122	STAR KNOB
123	P9953ZX123	HEX NUT M5-.8
124	P9953ZX124	SET SCREW M8-1.25 X 20
125	P9953ZX125	GREASE FITTING
901	P9953ZX901	FLAT HD TORX T20 M6-1 X 15
902	P9953ZX902	INDEXABLE INSERT 14 X 14 X 2
903	P9953ZX903	SPIRAL CUTTERHEAD BODY



# G9953ZX/ZXF Fence

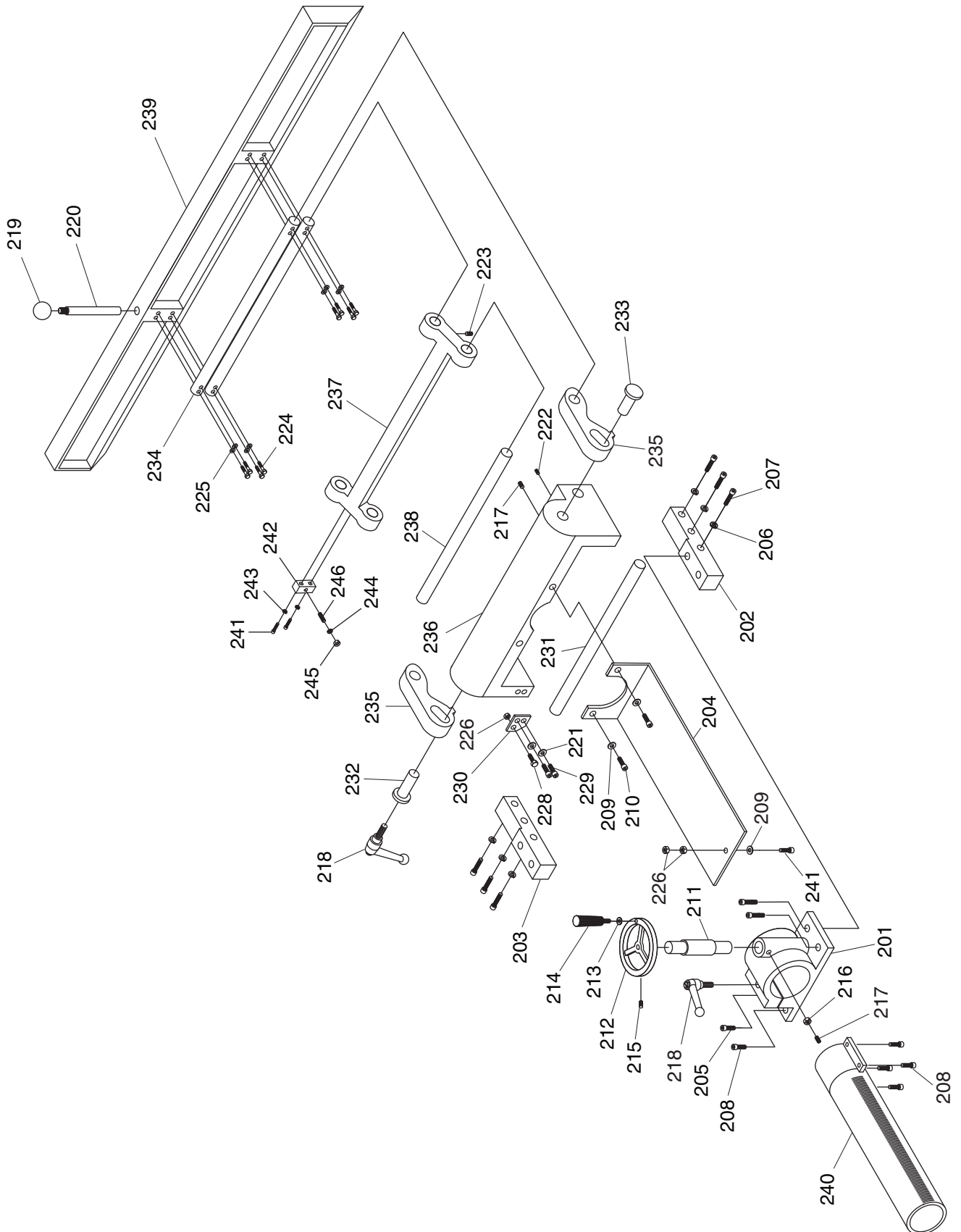

# G9953ZX/ZXF Fence Parts List

REF	PART #	DESCRIPTION
201	P9953ZX201	TUBE ROD BRACKET
202	P9953ZX202	CONNECTOR LEFT
203	P9953ZX203	CONNECTOR RIGHT
204	P9953ZX204	BASE PLATE
205	P9953ZX205	CAP SCREW M10-1.5 X 60
206	P9953ZX206	LOCK WASHER 8MM
207	P9953ZX207	CAP SCREW M8-1.25 X 50
208	P9953ZX208	CAP SCREW M10-1.5 X 25
209	P9953ZX209	FLAT WASHER 6MM
210	P9953ZX210	CAP SCREW M6-1 X 10
211	P9953ZX211	GEAR SHAFT
212	P9953ZX212	HANDWHEEL
213	P9953ZX213	FLAT WASHER 3/8
214	P9953ZX214	HANDLE 3/8-16
215	P9953ZX215	SET SCREW M8-1.25 X 10
216	P9953ZX216	HEX NUT M8-1.25
217	P9953ZX217	SET SCREW M8-1.25 X 25
218	P9953ZX218	LOCK LEVER 1/2 X 50MM
219	P9953ZX219	KNOB 3/8"
220	P9953ZX220	FENCE ADJUSTMENT HANDLE
221	P9953ZX221	FLAT WASHER 6MM
222	P9953ZX222	SET SCREW M6-1 X 10
223	P9953ZX223	SET SCREW M6-1 X 8

REF	PART #	DESCRIPTION
224	P9953ZX224	HEX BOLT M8-1.25 X 30
225	P9953ZX225	FLAT WASHER 8MM
226	P9953ZX226	HEX NUT M10-1.5
228	P9953ZX228	HEX BOLT M8-1.25 X 25
229	P9953ZX229	CAP SCREW M6-1 x 16
230	P9953ZX230	BRACKET
231	P9953ZX231	ANCHOR ROD
232	P9953ZX232	PIVOT PIN RIGHT
233	P9953ZX233	PIVOT PIN LEFT
234	P9953ZX234	FENCE ROD
235	P9953ZX235	PIVOT ARM
236	P9953ZX236	FENCE ANGLE SEAT
237	P9953ZX237	FENCE ROD BRACKET
238	P9953ZX238	PIVOT ROD
239	P9953ZX239	FENCE
240	P9953ZX240	FENCE ROD
241	P9953ZX241	CAP SCREW M6-1 X 25
242	P9953ZX242	FENCE STOP BLOCK
243	P9953ZX243	FLAT WASHER 1/4
244	P9953ZX244	FLAT WASHER 5/16
245	P9953ZX245	HEX NUT M8-1.25
246	P9953ZX246	SET SCREW M8-1.25 X 40



# G9953ZX/ZXF Table

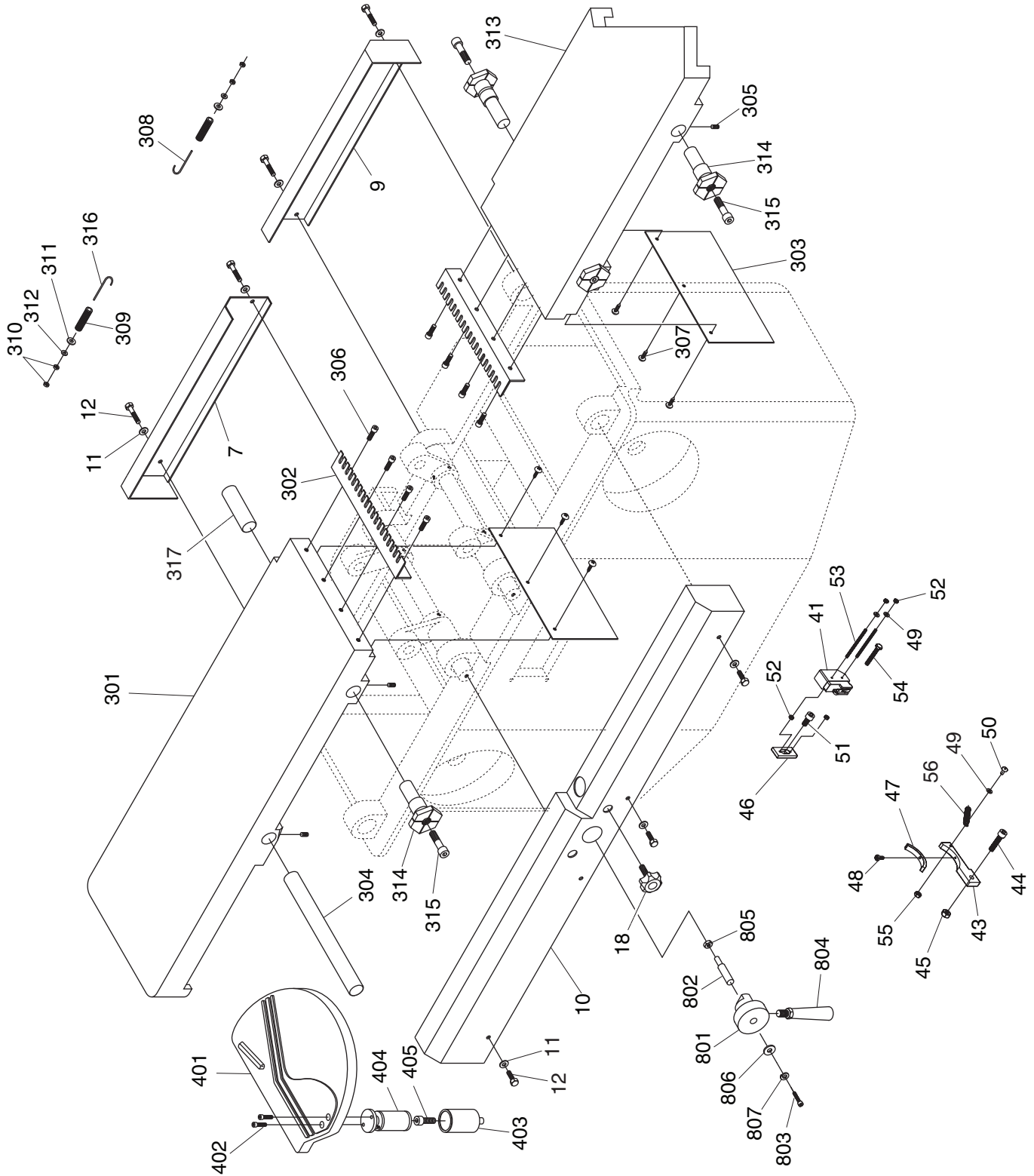

# G9953ZX/ZXF Table Parts List

REF	PART #	DESCRIPTION
7	P9953ZX007	OUTFEED TABLE REAR HOUSING
9	P9953ZX009	INFEED TABLE REAR HOUSING
10	P9953ZX010	FRONT TABLE COVER
11	P9953ZX011	FLAT WASHER 8MM
12	P9953ZX012	HEX BOLT M8-1.25 X 16
18	P9953ZX018	KNOB 3/8-16 X 1-1/2
41	P9953ZX041	BRAKE SWITCH
43	P9953ZX043	BRAKE PLATE
44	P9953ZX044	CAP SCREW M8-1.25 X 35
45	P9953ZX045	HEX NUT M8-1.25
46	P9953ZX046	BRAKE BRACKET
47	P9953ZX047	BRAKE PAD
48	P9953ZX048	PHLP HD SCR 10-24 X 1/2
49	P9953ZX049	FLAT WASHER #10
50	P9953ZX050	PHLP HD SCR 10-24 X 3/8
51	P9953ZX051	CAP SCREW M8-1.25 X 16
52	P9953ZX052	HEX NUT M4-.7
53	P9953ZX053	SET SCREW M4-.7 X 65
54	P9953ZX054	HEX BOLT M6-1 X 45
55	P9953ZX055	HEX NUT M6-1
56	P9953ZX056	TENSION SPRING
301	P9953ZX301	OUTFEED TABLE
302	P9953ZX302	NOISE DAMPER
303	P9953ZX303	COVER
304	P9953ZX304	TABLE PIVOT ROD (LONG)

REF	PART #	DESCRIPTION
305	P9953ZX305	SET SCREW M8-1.25 X 10
306	P9953ZX306	CAP SCREW M6-1 X 16
307	P9953ZX307	PHLP HD SCR M6-1 X 12
308	P9953ZX308	J-ROD (LONG)
309	P9953ZX309	TENSION SPRING
310	P9953ZX310	HEX NUT M12-1.75
311	P9953ZX311	FLAT WASHER 1/2
312	P9953ZX312	FLAT WASHER 3/8
313	P9953ZX313	INFEED TABLE
314	P9953ZX314	BED PIVOT PIN
315	P9953ZX315	CAP SCREW M10-1.5 X 45
316	P9953ZX316	J-ROD (SHORT)
317	P9953ZX317	TABLE PIVOT ROD (SHORT)
401	P9953ZX401	CUTTERHEAD GUARD
402	P9953ZX402	CAP SCREW M6-1 X 25
403	P9953ZX403	SPRING SHAFT HOUSING
404	P9953ZX404	SPRING SHAFT
405	P9953ZX405	CAP SCREW M12-1.75 X 20
801	P9953ZX801	HANDLE HUB
802	P9953ZX802	SHAFT
803	P9953ZX803	CAP SCREW M5-.8 X 15
804	P9953ZX804	HANDLE
805	P9953ZX805	HEX NUT 5/16"-24
806	P9953ZX806	FLAT WASHER 5MM
807	P9953ZX807	LOCK WASHER 5MM



# G9953ZX/ZXF Handwheel

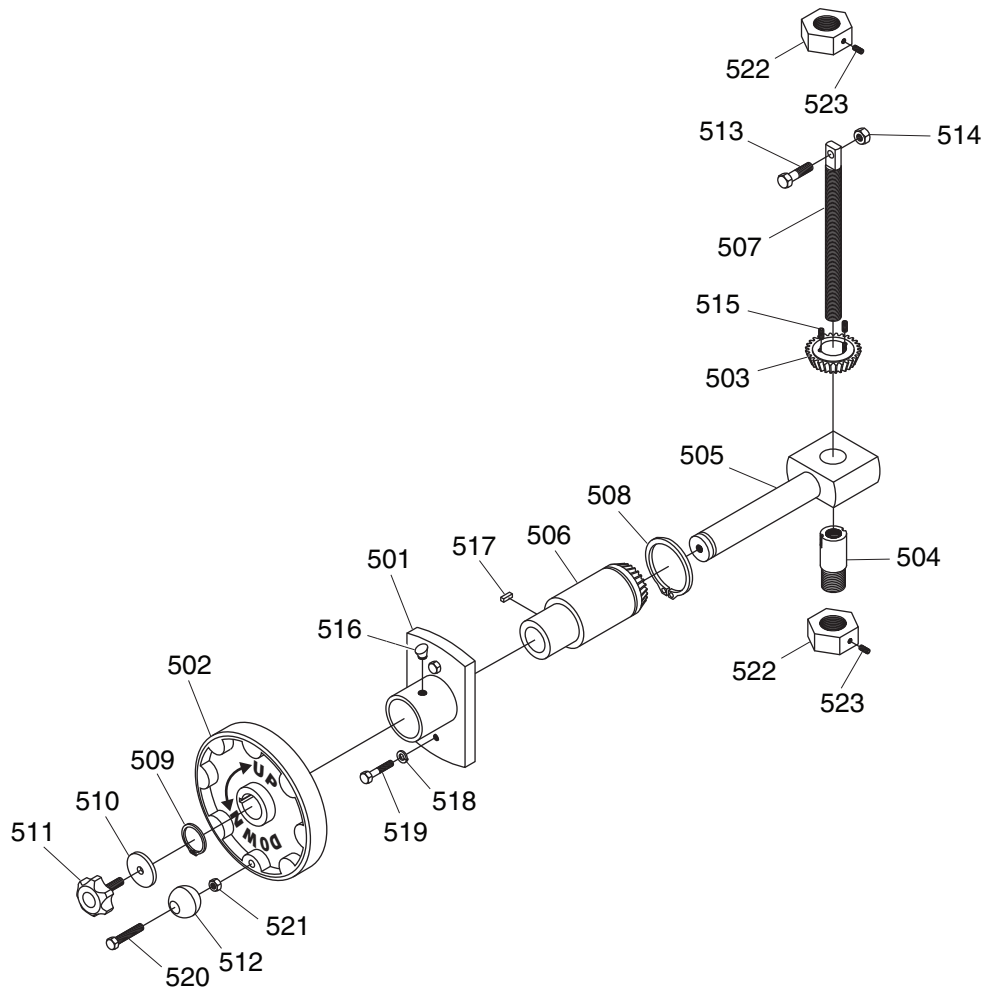

REF	PART #	DESCRIPTION
501	P9953ZX501	LIFT ROD BRACKET
502	P9953ZX502	HANDWHEEL
503	P9953ZX503	BEVEL GEAR
504	P9953ZX504	SLEEVE
505	P9953ZX505	LIFT ROD
506	P9953ZX506	GEAR SHAFT
507	P9953ZX507	LIFT CONNECTOR
508	P9953ZX508	SPECIAL EXT RETAINER RING
509	P9953ZX509	EXT RETAINING RING 22MM
510	P9953ZX510	SPECIAL FLAT WASHER D12 X 8MM
511	P9953ZX511	LOCK KNOB M10-1.5 X 20MM
512	P9953ZX512	HANDWHEEL KNOB 3/8"-16

REF	PART #	DESCRIPTION
513	P9953ZX513	CAP SCREW M10-1.5 X 40
514	P9953ZX514	HEX NUT M10-1.5
515	P9953ZX515	SET SCREW M4-.7 X 10
516	P9953ZX516	GREASE FITTING
517	P9953ZX517	KEY 5 X 5 X 15
518	P9953ZX518	LOCK WASHER 8MM
519	P9953ZX519	HEX BOLT M8-1.25 X 25
520	P9953ZX520	HEX BOLT 3/8-16 X 2
521	P9953ZX521	HEX NUT 3/8"-16
522	P9953ZX522	SPECIAL NUT M25-1.5
523	P9953ZX523	SET SCREW M6-1 X 6



# G9953ZX/ZXF Motor

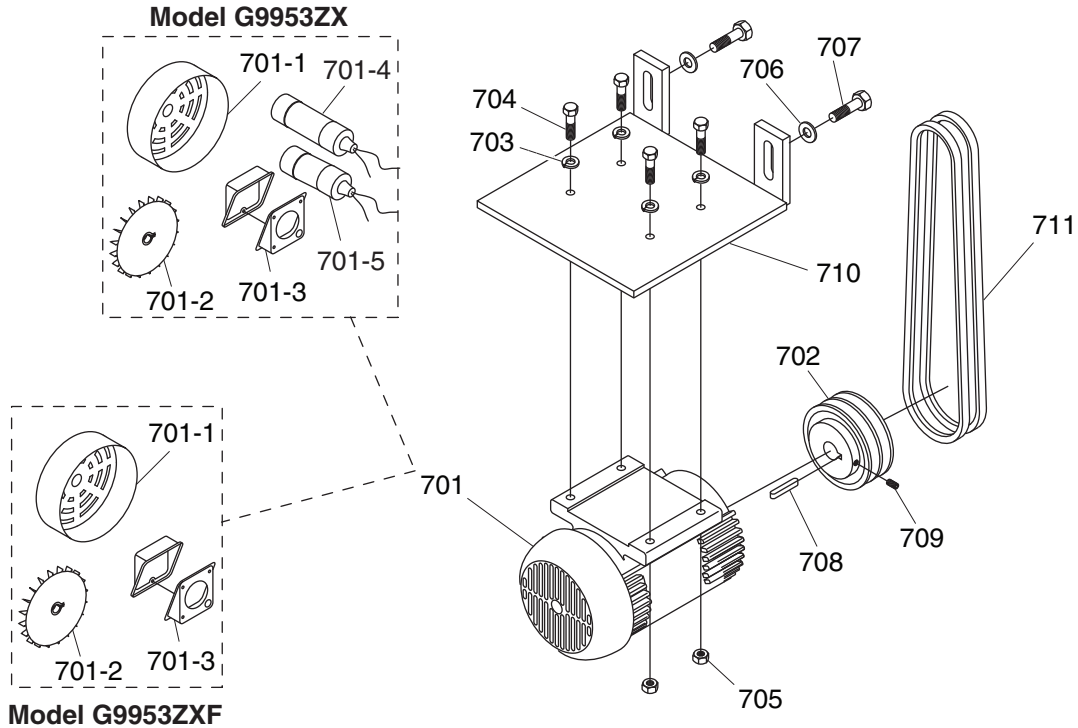

## G9953ZX Motor Parts List

REF	PART #	DESCRIPTION
701	P9953ZX701	MOTOR 5 HP 220V 1PH
701-1	P9953ZX701-1	MOTOR FAN COVER
701-2	P9953ZX701-2	MOTOR FAN
701-3	P9953ZX701-3	MOTOR WIRING JUNCTION BOX
701-4	P9953ZX701-4	S CAP. 800MFD 250V 2-7/8 X 3-1/4
701-5	P9953ZX701-5	R CAP. 30M 350V 3 X 2
702	P9953ZX702	MOTOR PULLEY
703	P9953ZX703	LOCK WASHER 10MM

REF	PART #	DESCRIPTION
704	P9953ZX704	HEX BOLT M10-1.5 X 40
705	P9953ZX705	HEX NUT M10-1.5
706	P9953ZX706	FLAT WASHER 12MM
707	P9953ZX707	HEX BOLT M12-1.75 X 25
708	P9953ZX708	KEY 7 X 7 X 65
709	P9953ZX709	SET SCREW M8-1.25 X 20
710	P9953ZX710	MOTOR MOUNT PLATE
711	P9953ZX711	V-BELT A50

## G9953ZXF Motor Parts List

REF	PART #	DESCRIPTION
701	P9953ZXF701	MOTOR 5 HP 220V 3PH
701-1	P9953ZXF701-1	MOTOR FAN COVER
701-2	P9953ZXF701-2	MOTOR FAN
701-3	P9953ZXF701-3	MOTOR WIRING JUNCTION BOX
702	P9953ZXF702	MOTOR PULLEY
703	P9953ZXF703	LOCK WASHER 10MM
704	P9953ZXF704	HEX BOLT M10-1.5 X 40

REF	PART #	DESCRIPTION
705	P9953ZXF705	HEX NUT M10-1.5
706	P9953ZXF706	FLAT WASHER 12MM
707	P9953ZXF707	HEX BOLT M12-1.75 X 40
708	P9953ZXF708	KEY 7 X 7 X 65
709	P9953ZXF709	SET SCREW M8-1.25 X 20
710	P9953ZXF710	MOTOR MOUNT PLATE
711	P9953ZXF711	V-BELT A50



# Labels & Cosmetics

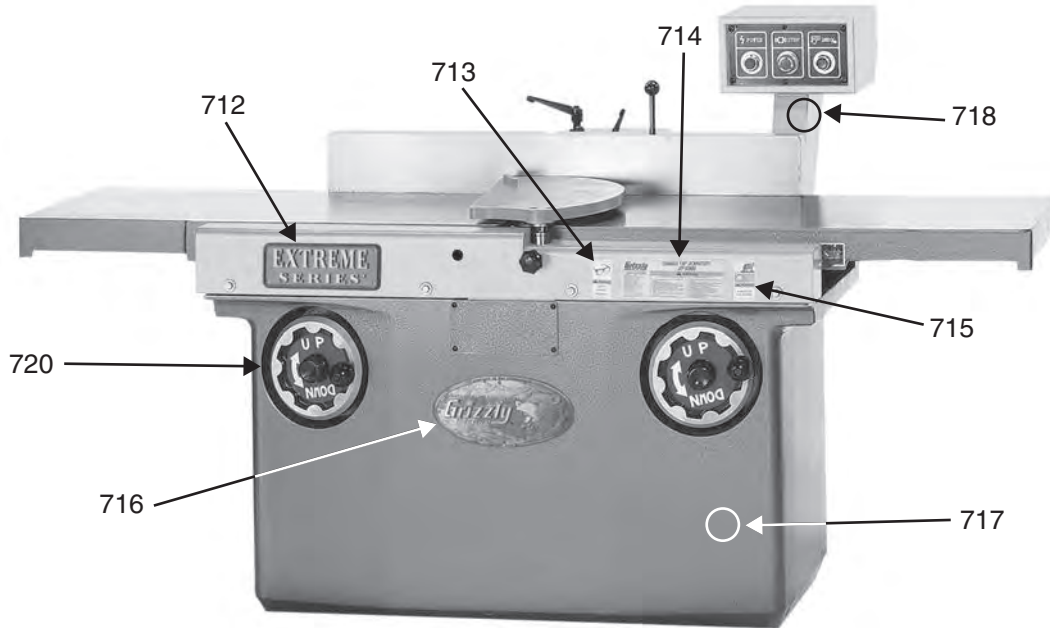

REF	PART #	DESCRIPTION
712	P9860712	EXTREME SERIES NAMEPLATE
713	P9860713	EYE HAZARD LABEL
714	P9860714	MACHINE ID LABEL (G9860)
714	P9860ZX714	MACHINE ID LABEL (G9860ZX)
714	P9953ZX714	MACHINE ID LABEL (G9953ZX)
714	P9953ZXF714	MACHINE ID LABEL (G9953ZXF)
715	P9860715	PUSH BLOCK WARNING
716	P9860716	GRIZZLY NAMEPLATE-LARGE

REF	PART #	DESCRIPTION
717	P9860717	GRIZZLY GREEN TOUCH-UP PAINT
718	P9860718	GRIZZLY PUTTY TOUCH-UP PAINT
719*	P9860719	MODEL NO. LABEL (G9860)
719*	P9860ZX719	MODEL NO. LABEL (G9860ZX)
719*	P9953ZX719	MODEL NO. LABEL (G9953ZX)
719*	P9953ZXF719	MODEL NO. LABEL (G9953ZXF)
720	P9860720	HANDWHEEL UP/DOWN LABEL

\* Not Shown

## WARNING

Safety labels help reduce the risk of serious injury caused by machine hazards. If any label comes off or becomes unreadable, the owner of this machine **MUST** replace it in the original location before resuming operations. For replacements, contact (800) 523-4777 or [www.grizzly.com](http://www.grizzly.com).

