

H6151 Parts Breakdown & List

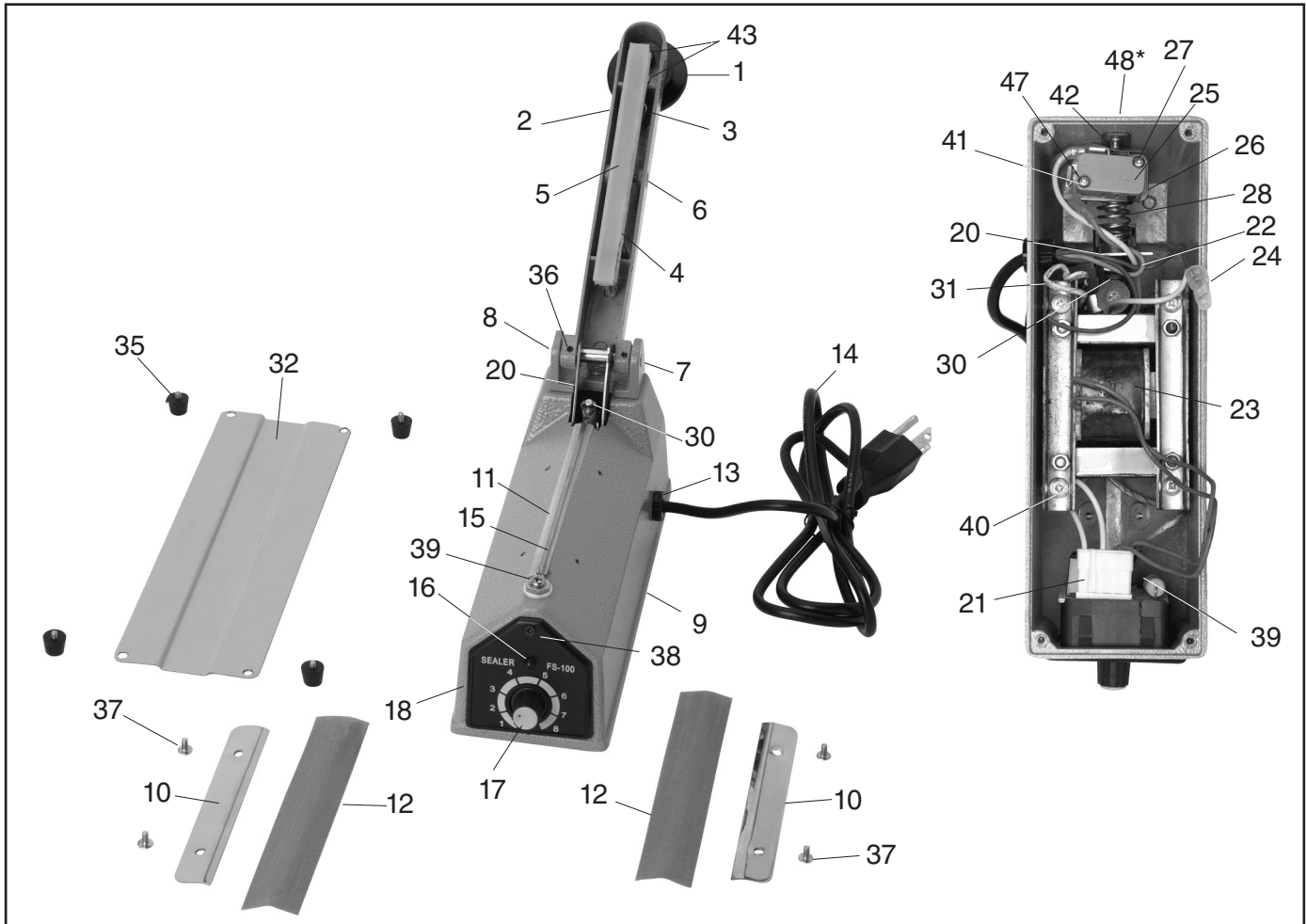

REF	PART #	DESCRIPTION
1	PH6151001	HANDLE KNOB
2	PH6151002	PLATEN ARM
3	PH6151003	PLATEN SPRING
4	PH6151004	PLATEN
5	PH6151005	SILICON RUBBER STRIP
6	PS01M	PHLP HD SCR M4-.7 X 18
7	PH6151007	HINGE
8	PH6151008	HINGE BRACKET
9	PH6151009	SEALER BASE
10	PH6151010	METAL PLATE
11	PH6151011	LOWER TEFLON ELEMENT
12	PH6151012	UPPER TEFLON CLOTH
13	PH6151013	STRAIN RELIEF
14	PH6151014	POWER CORD
15	PH6151015	HEATING ELEMENT
16	PH6151016	PILOT LAMP
17	PH6151017	TIMER KNOB
18	PH6151018	CONTROL PANEL ASSEMBLY
20	PH6151020	SWITCH LEVER
21	PH6151021	WIRE CONNECTOR
22	PH6151022	INTERNAL WIRING

REF	PART #	DESCRIPTION
23	PH6151023	HEATER TRANSFORMER
24	PH6151024	WIRE CONNECTOR
25	PH6151025	MICROSWITCH
26	PH6151026	SWITCH BRACKET
27	PH6151027	SWITCH INSULATION
28	PH6151028	SWITCH LEVER SPRING
30	PH6151030	HEATER TERMINAL ASSEMBLY
31	PH6151031	GROUNDING WIRE
32	PH6151032	COVER PLATE
35	PH6151035	RUBBER FOOT AND SCREW
36	PSS81M	SET SCREW M3-.5 X 5
37	PS12M	PHLP HD SCR M3-.5 X 6
38	PFH57M	FLAT HD SCR M3-.5 X 8
39	PS17M	PHLP HD SCR M4-.7 X 6
40	PS18M	PHLP HD SCR M4-.7 X 25
41	PS59M	PHLP HD SCR M3-.5 X 14
42	PS07M	PHLP HD SCR M4-.7 X 8
43	PSB04M	CAP SCREW M6-1 X 10
47	PLW09M	LOCK WASHER 3MM
48*	PTLW01M	EXT TOOTH WASHER 4MM

* Part not shown in breakdown

